

STEP ONE

LAY THE FUSELAGE SIDE ON THE PLAN AND MARK THE POSITION OF F-1. GLUE ON THE NOSE DOUBLER AND THE SIDE DOUBLER LEAVING A 1/8" SLOT FOR F-1.

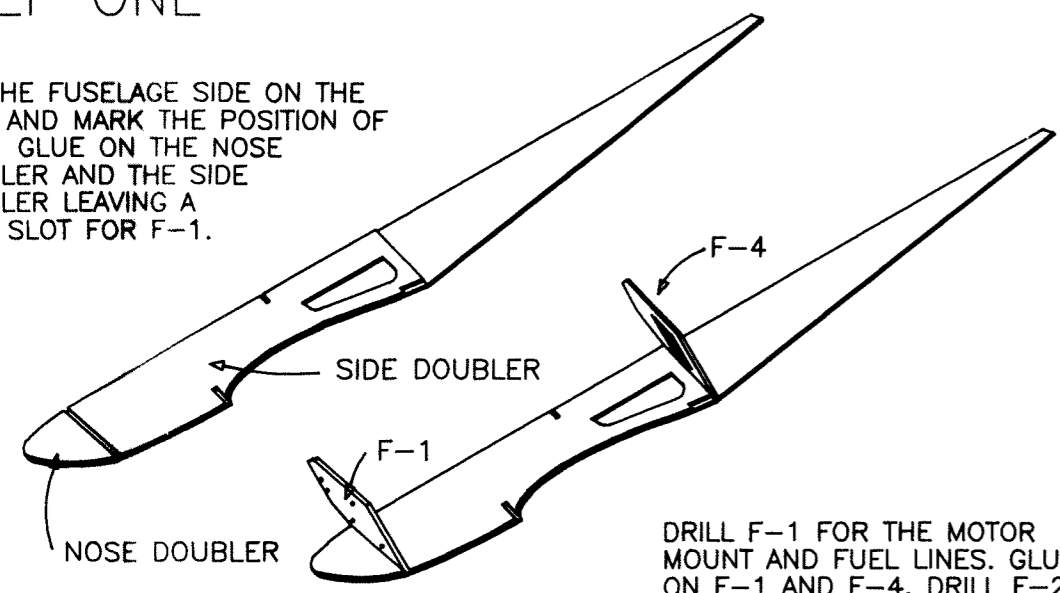

DRILL F-1 FOR THE MOTOR MOUNT AND FUEL LINES. GLUE ON F-1 AND F-4. DRILL F-2 FOR THE WING MOUNT DOWEL.

STEP TWO

GLUE ON THE OTHER FUSELAGE SIDE. GLUE IN F-2, F-3 AND F-5.

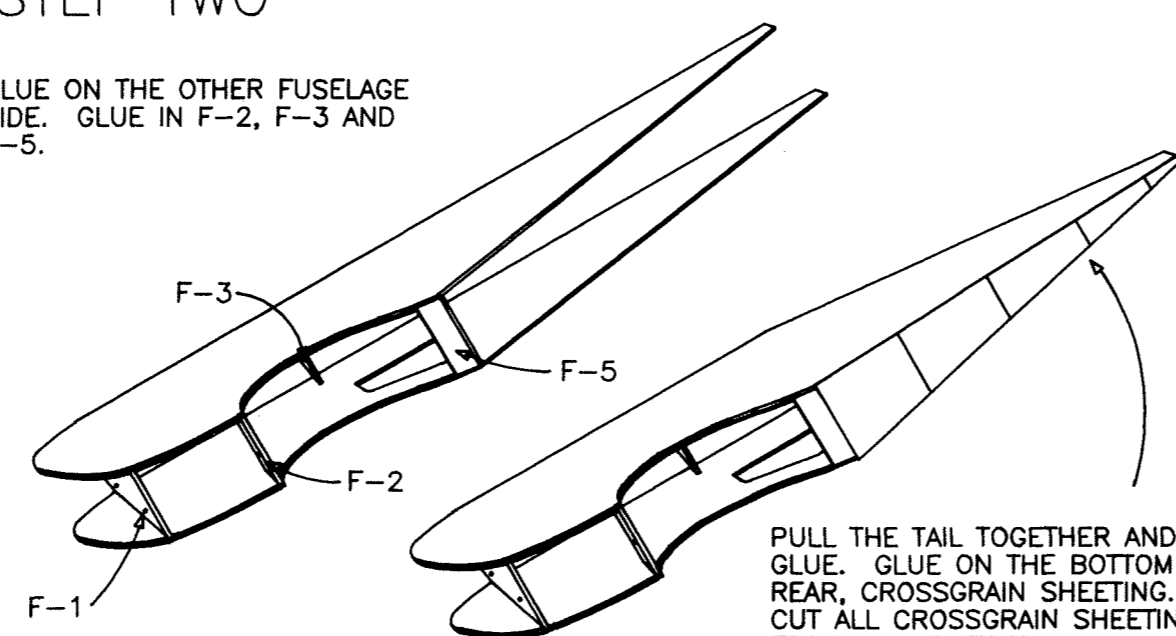

PULL THE TAIL TOGETHER AND GLUE. GLUE ON THE BOTTOM REAR, CROSSGRAIN SHEETING. CUT ALL CROSSGRAIN SHEETING FROM SHEET STOCK.

STEP THREE

GLUE ON THE TOP FRONT SIDES AND THE TOP FRONT. ALL OF THE TOP SHEETING AND COCKPIT FLOOR IS GLUED ON CROSSGRAIN AND IS CUT FROM SHEET STOCK.

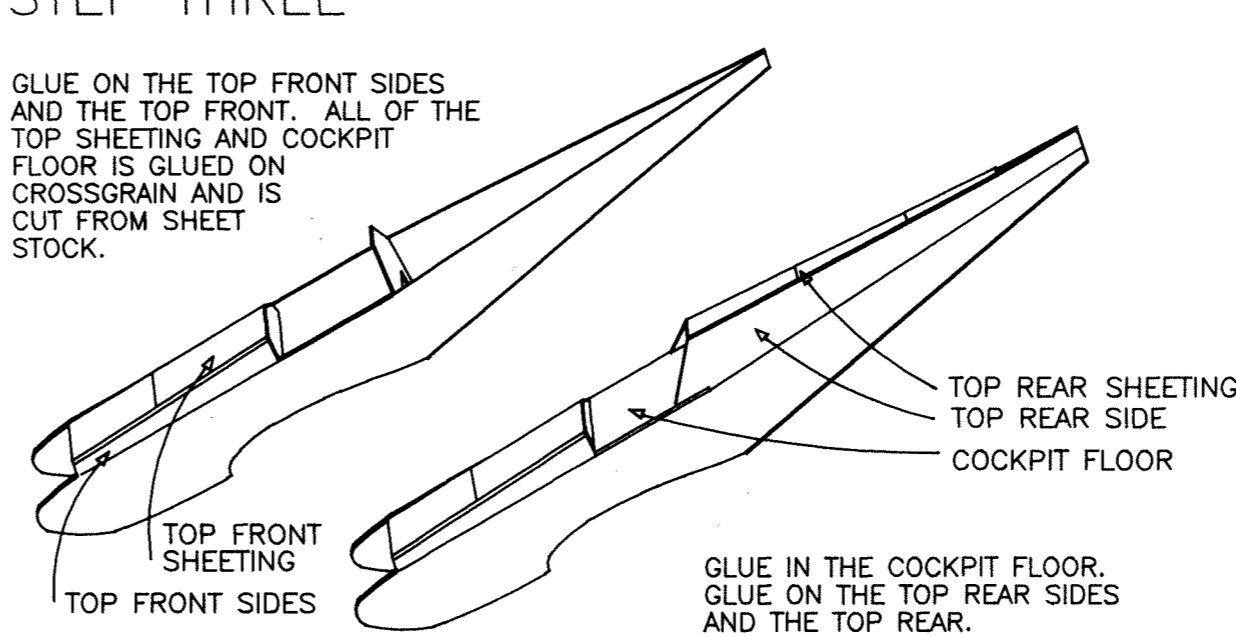

GLUE IN THE COCKPIT FLOOR. GLUE ON THE TOP REAR SIDES AND THE TOP REAR.

INSTRUCTIONS

TOOLS AND ADHESIVES NEEDED TO BUILD THIS MODEL ARE: X-ACTO KNIFE, SCREWDRIVERS, PLIERS, DRILL WITH 1/16", 1/8" AND 5/32" DRILL BITS AND BOTH FINE AND MEDIUM SANDPAPER. FOR GLUE WE RECOMMEND MEDIUM VISCOSITY CYA GLUE FOR ALL WOOD TO WOOD JOINTS. FOR WOOD TO FOAM USE WHITE GLUE OR EPOXY. USE EPOXY ONLY TO JOIN THE TWO WING HALVES.

STEP ONE: BUILD THE MODEL USING THE PICTURE SEQUENCE AS A GUIDE. LAY THE FUSELAGE SIDES OVER THE PLAN AND NOTE THE MARKS VISIBLE ON THE PLAN ABOVE AND BELOW F-1. USE THESE MARKS TO POSITION THE DOUBLERS. THE NOSE DOUBLER IS GLUED ON AHEAD OF THE FORWARD MARKS AND THE SIDE DOUBLER IS GLUED ON BEHIND THE REAR MARKS. THIS LEAVES A 1/8" SLOT FOR F-1 BETWEEN THE DOUBLERS. DRILL F-1 FOR THE ENGINE MOUNT AND FUEL LINES. DRILL F-2 FOR THE WING MOUNT DOWEL. GLUE IN THE ENGINE MOUNT BLIND NUTS. GLUE F-1 AND F-4 TO ONE OF THE FUSELAGE SIDES.

STEP TWO: GLUE ON THE OTHER FUSELAGE SIDE. GLUE IN F-2, F-3 AND F-5. PULL THE FUSELAGE SIDES TOGETHER AT THE TAIL AND GLUE. ADD THE CROSSGRAIN Balsa BOTTOM REAR SHEETING.

STEP THREE: BEVEL SAND THE BOTTOM EDGES OF THE TOP FRONT SIDES BEFORE GLUING TO THE FUSELAGE. SAND THE TOP EDGES BEFORE GLUING ON THE CROSSGRAIN Balsa TOP. GLUE IN THE COCKPIT FLOOR. GLUE ON THE TOP REAR SIDES STARTING FROM THE BACK. GLUE ON THE TOP CROSSGRAIN SHEETING CUT FROM SHEET STOCK.

STEP FOUR: GLUE THE 1/8" X 1/4" Balsa STRIPS TO THE TRAILING EDGE OF THE WING PANELS. ASSEMBLE AND BEND THE AILERON LINKAGE TO MATCH THE PLAN. NOTCH THE INBOARD SECTION FOR THE AILERON LINKAGE AND GLUE IN PLACE. FIT THE AILERONS SO THERE IS A 3/32" SPACE BETWEEN THE INBOARD SECTION AND THE AILERON. AFTER JOINING THE WING PANELS, LIGHTLY SAND OFF THE FLASHING ALONG THE LEADING EDGE AND THE LITTLE BUMPS ON THE SURFACE. USE FINE SANDPAPER (220 GRIT) FOR THIS JOB. BEFORE COVERING THE WING, APPLY A 3/4" WIDE STRIP OF FIBERGLASS STRAPPING TAPE FROM TIP TO TIP, TOP AND BOTTOM OF THE WING.

STEP FIVE: FIT THE WING INTO THE FUSELAGE. USING THE HOLE IN F-2 AS A GUIDE, DRILL A 1/8" HOLE INTO THE FOAM WING AND EPOXY THE WING MOUNT DOWEL INTO THE WING. INSTALL THE REAR WING MOUNT SCREW. REMOVE THE SCREW AND APPLY A DROP OF GLUE INTO THE HOLES TO HARDEN THE WOOD AROUND THE SCREW. GLUE ON THE PLYWOOD BOTTOM FRONT. FINISH SAND THE MODEL.

COVERING AND TRIM: COVER THE MODEL WITH LOW TEMPERATURE FILM IN LIGHT BLUE. THE GERMAN CAMOUFLAGE PAINT SCHEME CAN BE DONE WITH TRIM FILM OR PAINTED ON WITH CHEVRON'S WW2 COLORS IN SPRAY CANS IN DARK GREEN AND LIGHT SLATE GRAY OVER THE BASE OF LIGHT BLUE. COVER THE TAIL PARTS SEPARATELY AND APPLY TRIM BEFORE FINAL ASSEMBLY. CUT AWAY STRIPS OF FILM WHERE THERE WILL BE GLUE JOINTS. FIT THE CANOPY AND CUT AWAY A 1/8" WIDE STRIP OF FILM UNDER THE EDGE OF THE CANOPY AND EPOXY IN PLACE. CUT OUT THE DECALS, PEEL OFF AND APPLY. THE WING CROSSES ARE HALF WAY OUT ON THE WING.

STEP SIX: USE TWO STANDARD, MINI OR MICRO SERVOS FOR AILERON AND ELEVATOR CONTROL. WE USED STANDARD BATTERY PACKS IN OUR TEST MODELS. SMALLER PACKS CAN BE USED IF THE MODEL IS NOSE HEAVY. BALANCE THE MODEL BY SHIFTING THE RADIO IF POSSIBLE.

ENGINE AND FLYING: ANY OF THE COX .049 ENGINES CAN BE USED IN THE SIMPLE 109, BUT WE PREFER THE TD.049 OR TD.051 WITH A SEPARATE FUEL TANK FOR RELIABILITY. USE THE COX 6 X 3 GRAY COMPETITION PROPS AND COX SUPER POWER FUEL FOR THE BEST PERFORMANCE. FLY THE SIMPLE 109 FROM A GRASS FIELD BECAUSE THERE IS NO LANDING GEAR. LAUNCH THE MODEL WITH AN UNDERHAND TOSS HOLDING THE MODEL JUST AHEAD OF THE CANOPY. TAKE THE MODEL UP HIGH AND ADJUST THE TRIM. WRING IT OUT, RACE IT OR DOGFOIGHT IT. THE SIMPLE 109 IS FAST AND AGILE. ACHTUNI! WAS THAT A SIMPLE 51 THAT JUST FLEW BY? GO CATCH IT IF YOU CAN!

STEP FOUR

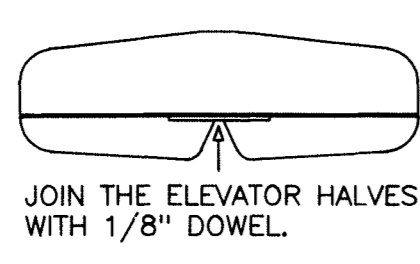
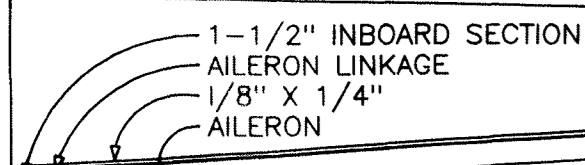

GLUE THE 1/8" X 1/4" STRIPS TO THE BACK EDGE OF THE WING PANELS. FIT THE AILERONS AND CUT OFF THE 1-1/2" INBOARD SECTION FOR THE LINKAGE.

NOTCH THE INBOARD SECTION FOR THE AILERON LINKAGE. GLUE THE LINKAGE AND THE INBOARD SECTION TO THE WING.

EPOXY THE WING PANELS TOGETHER, BLOCKING UP ON WING TIP 2". APPLY STRAPPING TAPE TOP AND BOTTOM, FROM TIP TO TIP.

JOIN THE ELEVATOR HALVES WITH 1/8" DOWEL.

GLUE THE RUDDER PARTS TOGETHER.

STEP FIVE

FIT THE WING TO THE FUSELAGE. DRILL THROUGH F-2 INTO THE WING AND EPOXY THE DOWEL INTO THE WING.

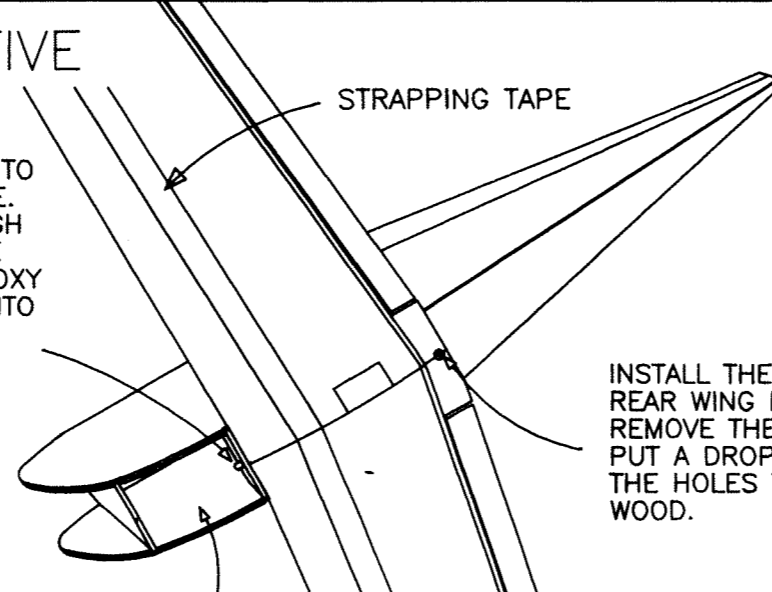

INSTALL THE #4 ST SCREW REAR WING HOLD DOWN. REMOVE THE SCREW AND PUT A DROP OF GLUE IN THE HOLES TO HARDEN THE WOOD.

AFTER THE WING MOUNTS ARE INSTALLED, GLUE ON THE 1/8" PLYWOOD BOTTOM FRONT.

STEP SIX

REFERRING TO THE BOTTOM OF THE FUSELAGE, GLUE IN THE DIECUT PLY SERVO RAILS USING THE TOP EDGE OF THE DOUBLER CUTOUT AS A LEDGE.

REFERRING TO THE TOP OF THE WING, INSTALL THE SERVOS, SWITCH AND LINKAGE. EZ CONNECTORS LINK THE 1/16" WIRE PUSHRODS TO THE SERVO ARMS AND PROVIDE ADJUSTMENTS. 90° BENDS AND NYLON KEEPERS SECURE THE PUSHRODS AT THE CONTROL HORNS.

WRAP THE RECEIVER AND BATTERY IN FOAM RUBBER.

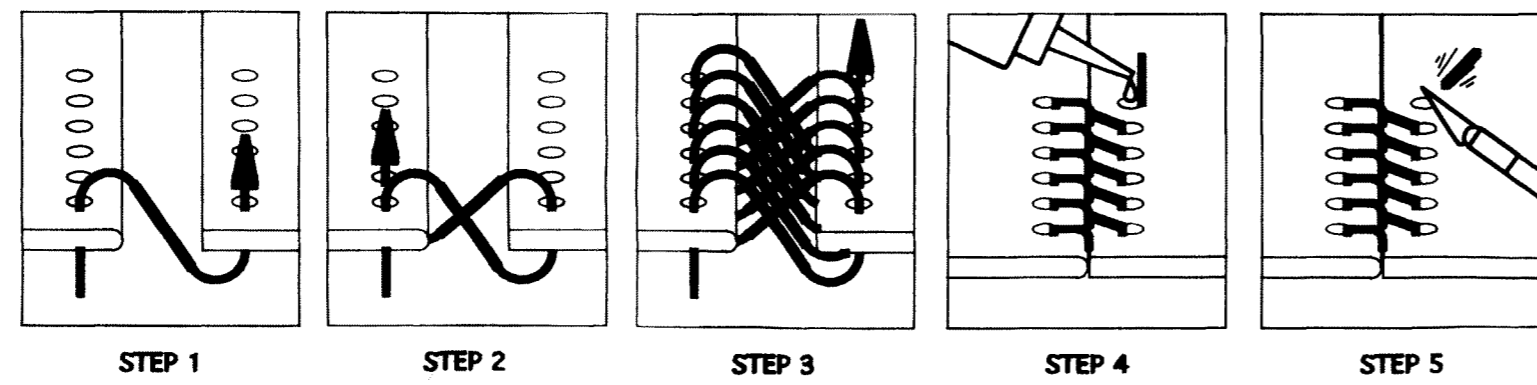
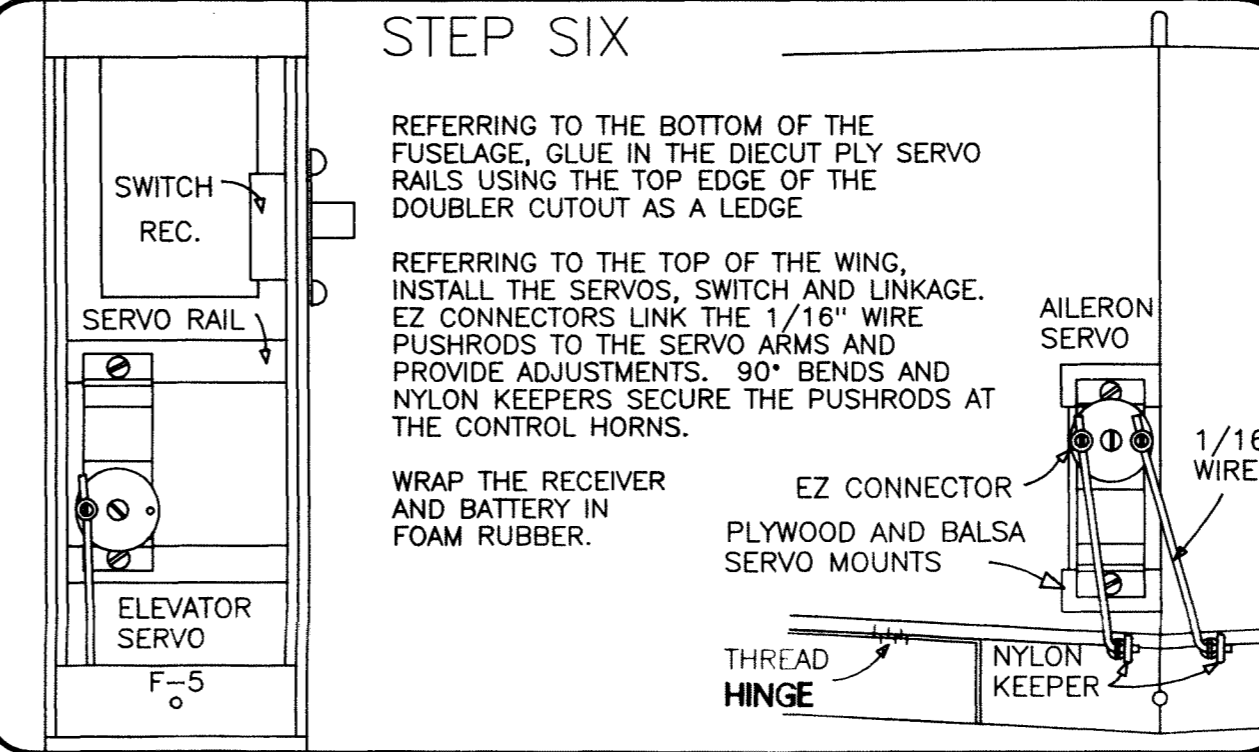
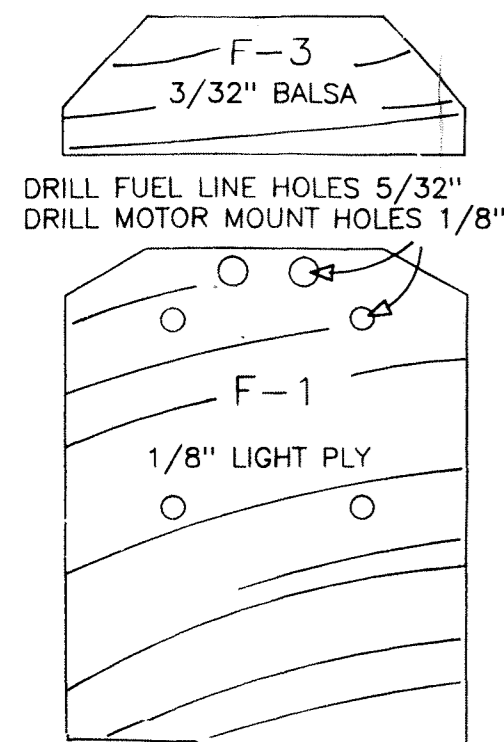
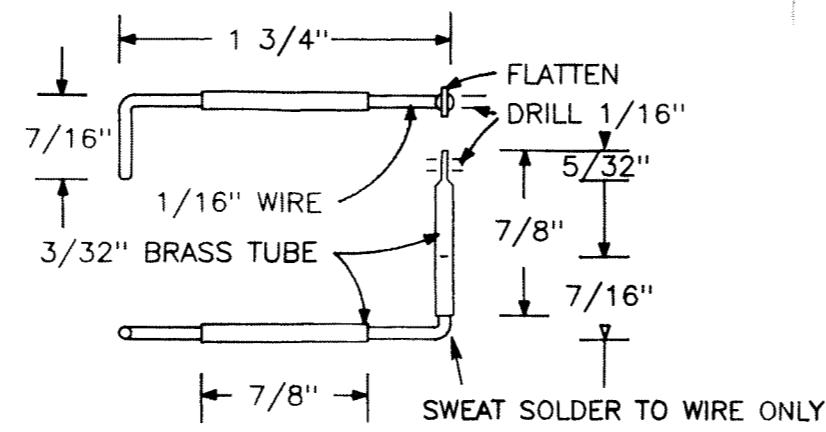
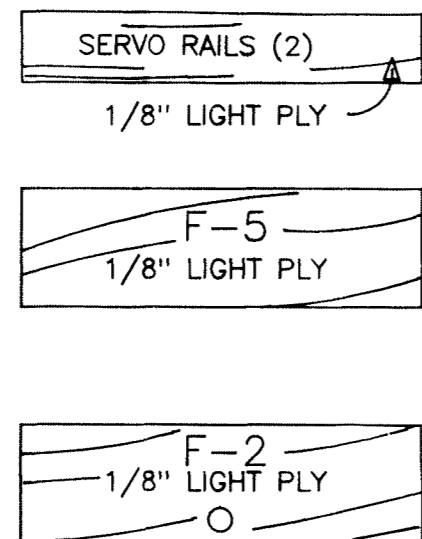
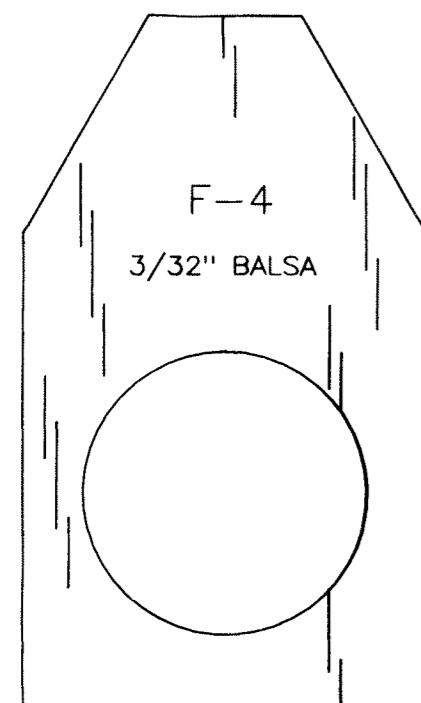

FIGURE 8 HINGE TECHNIQUE



DRILL FUEL LINE HOLES 5/32" DRILL MOTOR MOUNT HOLES 1/8"



AILERON LINKAGE MAKE ONE RIGHT AND ONE LEFT

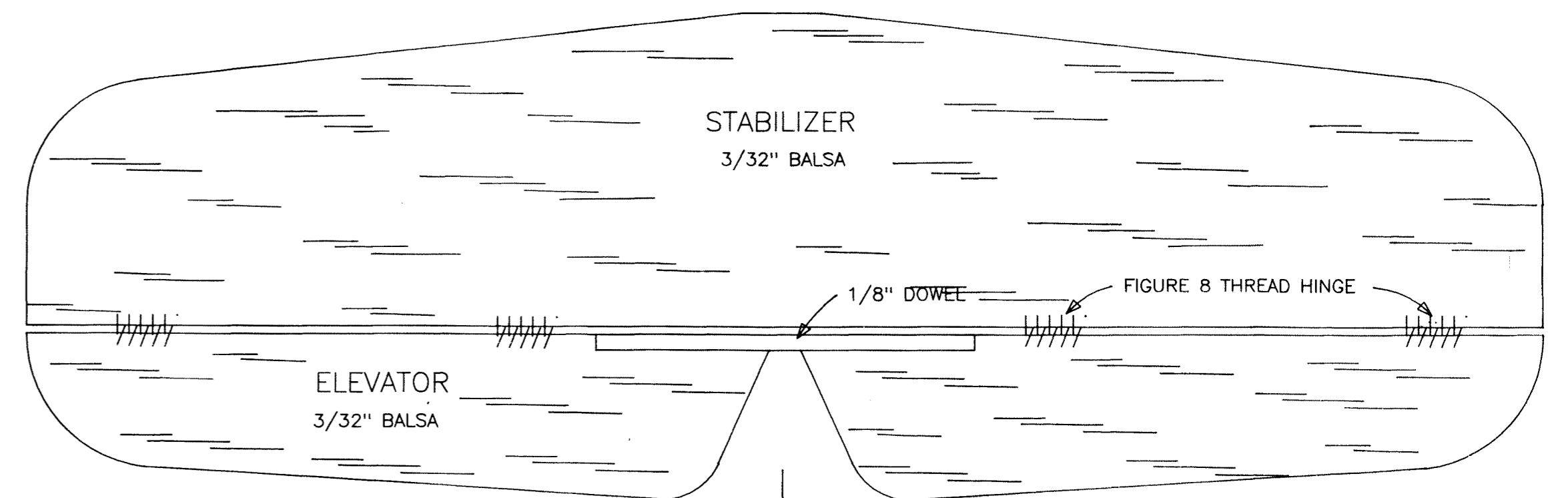

CONTROL MOVEMENT
AILERON: 5/32" UP AND DOWN
ELEVATOR: 3/8" UP AND DOWN

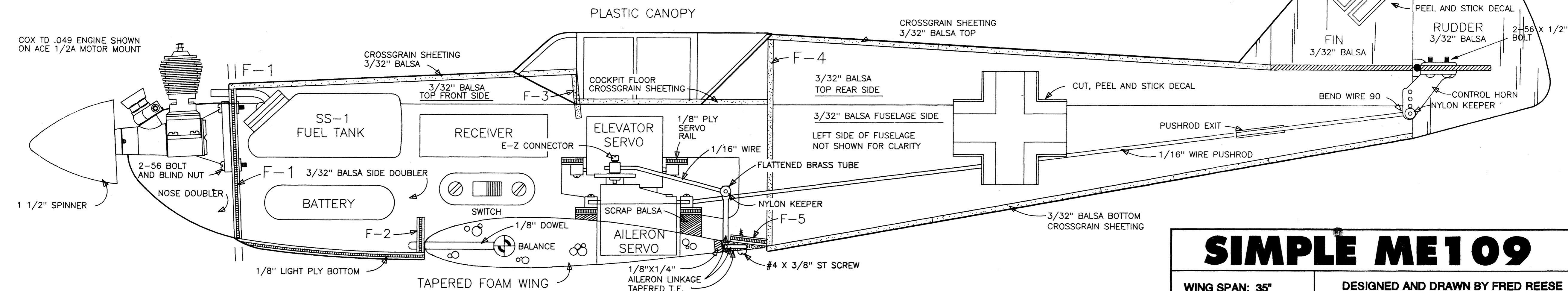
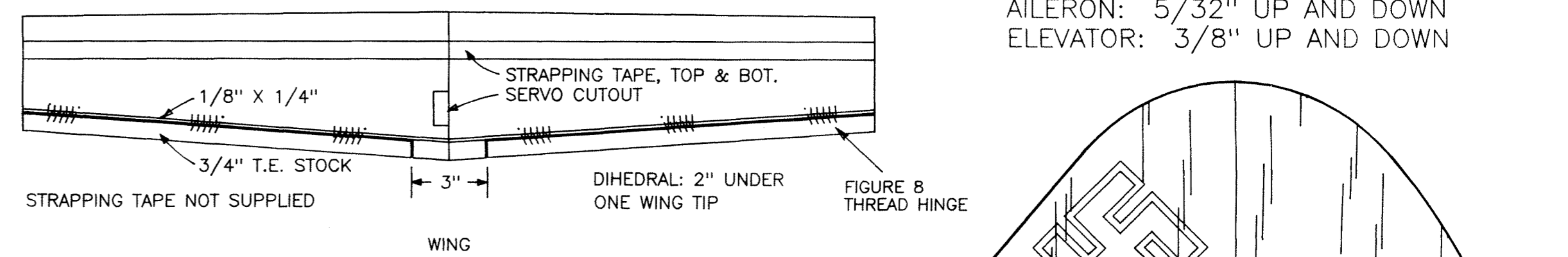

SIMPLE ME109

WING SPAN: 35"
WING AREA: 188 SQ IN
LENGHT: 27"
WEIGHT: 18 OZ
ENGINE: .049
RADIO: 2 CHANNEL

DESIGNED AND DRAWN BY FRED REESE

© 1993 ACE R/C, INC.

ACE R/C, INC.

116 W 19 ST, POB472, HIGGINSVILLE, MO 64037-0472