

1/4" UP 1" DOWN AT TIP

CUT HERE FOR RIBS FORWARD OF AILERON IN TOP WING ONLY

USE MONOPOTE FOR AILERON HINGE

TIP RIB ONLY (BOTH WINGS)

TYPICAL RIB

TOP WING

BOTTOM WING

HARD BALSA LEADING EDGE

ALL RIBS ARE 1/16 BALSA SHEET UNLESS NOTED, FALSE RIBS ARE 1/16 BALSA SHEET

NOTE: USE CURVED NYROD OR BELL CRANKS & PUSHRODS FOR AILERON CONTROL

CABANE STRUCTURE ONLY

TYPICAL WING RIGGING DETAIL

HARDWOOD CABANE T.E.

3/32 PIANO WIRE MOUNTING HOOKS (8 REQUIRED)

ROUND ENDS TO AVOID CUTTING RUBBER BANDS

SERVO

1/32 PLY BOTTOM

HARDWOOD CABANE L.E.

1/8 PLY

1/8 PLY

1/8 PLY

1/8 PLY

1/8 PLY

1/8 PLY

1/8 PLY

1/32 PLY

1/8 PLY

1/32 PLY HATCH COVER

1/8 PLY

1/8 PLY

1/8 PLY

1/8 PLY

1/8 PLY

1/8 PLY

1/8 PLY

1/8 PLY

1/8 PLY

CUT WING STRUTS FROM 1/8 ALUMINUM WELDING ROD OR STEEL COAT HANGER WIRE. COVER WINGS, PIERCE COVERING OVER SOCKET HOLES. PUSH STRUTS INTO SOCKETS & INSTALL RIGGING

1/64 STAINLESS STEEL FISH LEADER

DIAGONAL "FLYING" & LANDING WIRES

1/4 INCH WOOD DOWEL STRUT SOCKETS. BLIND DRILL 1/8 DIA X 1/2 DEEP EPOXY INTO WING AGAINST RIBS & SPARS

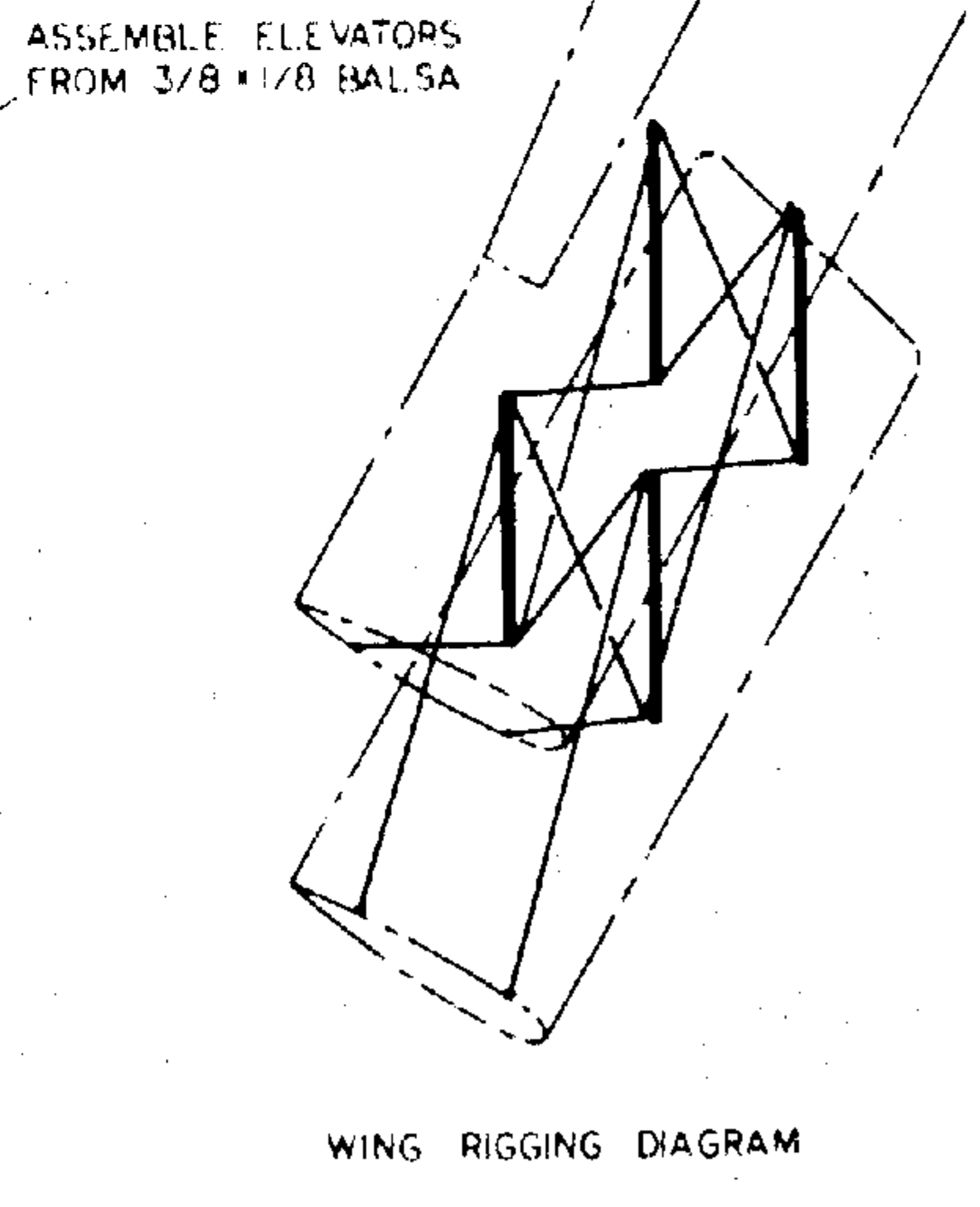
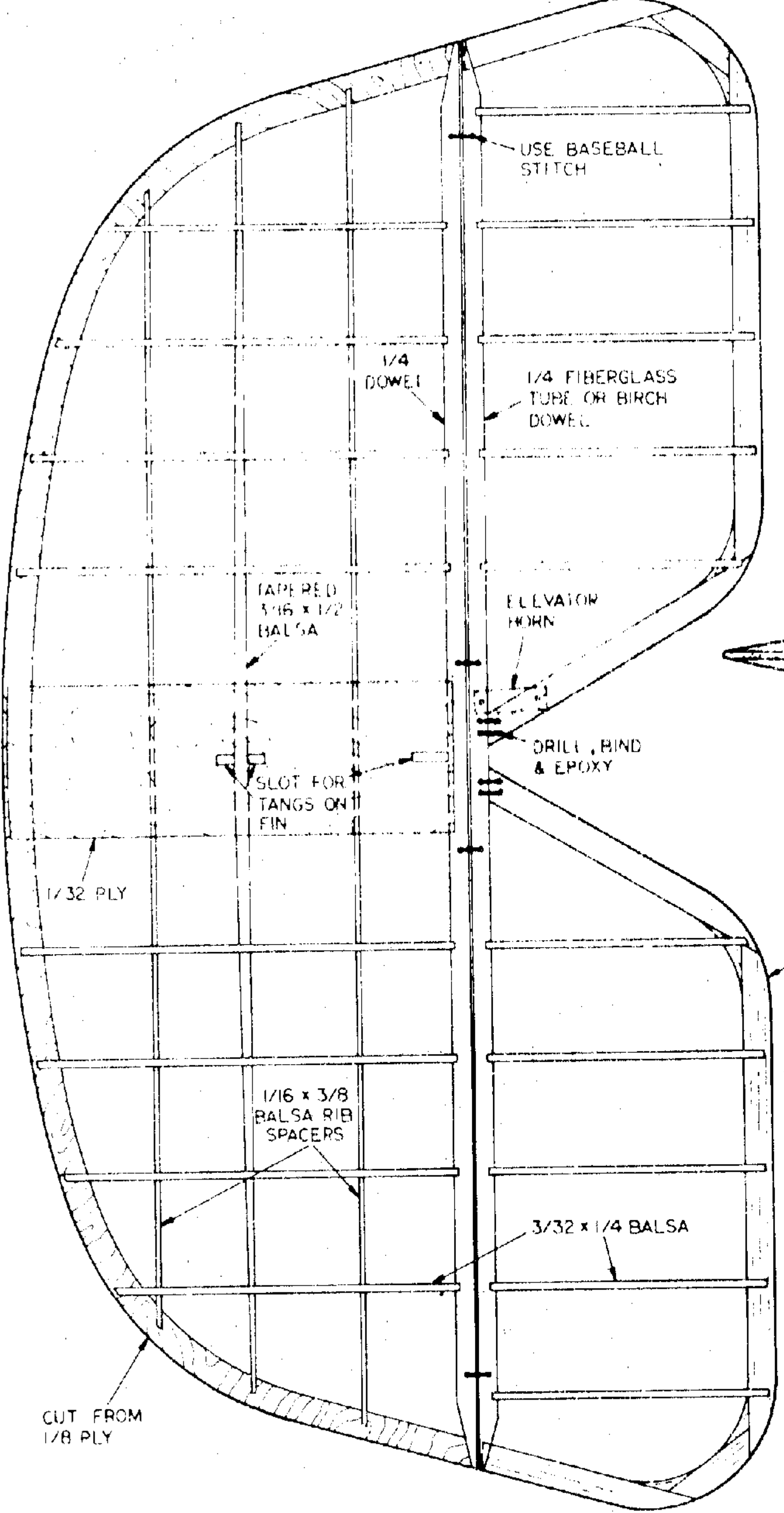
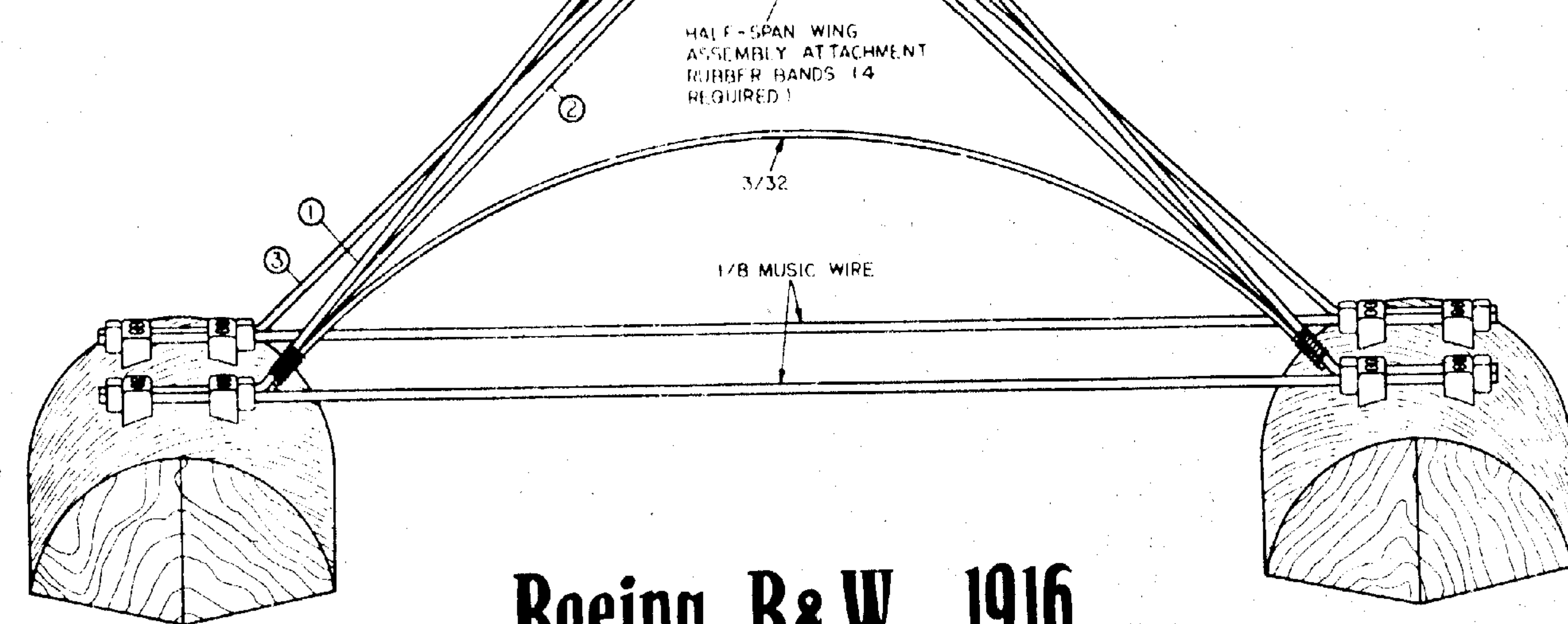
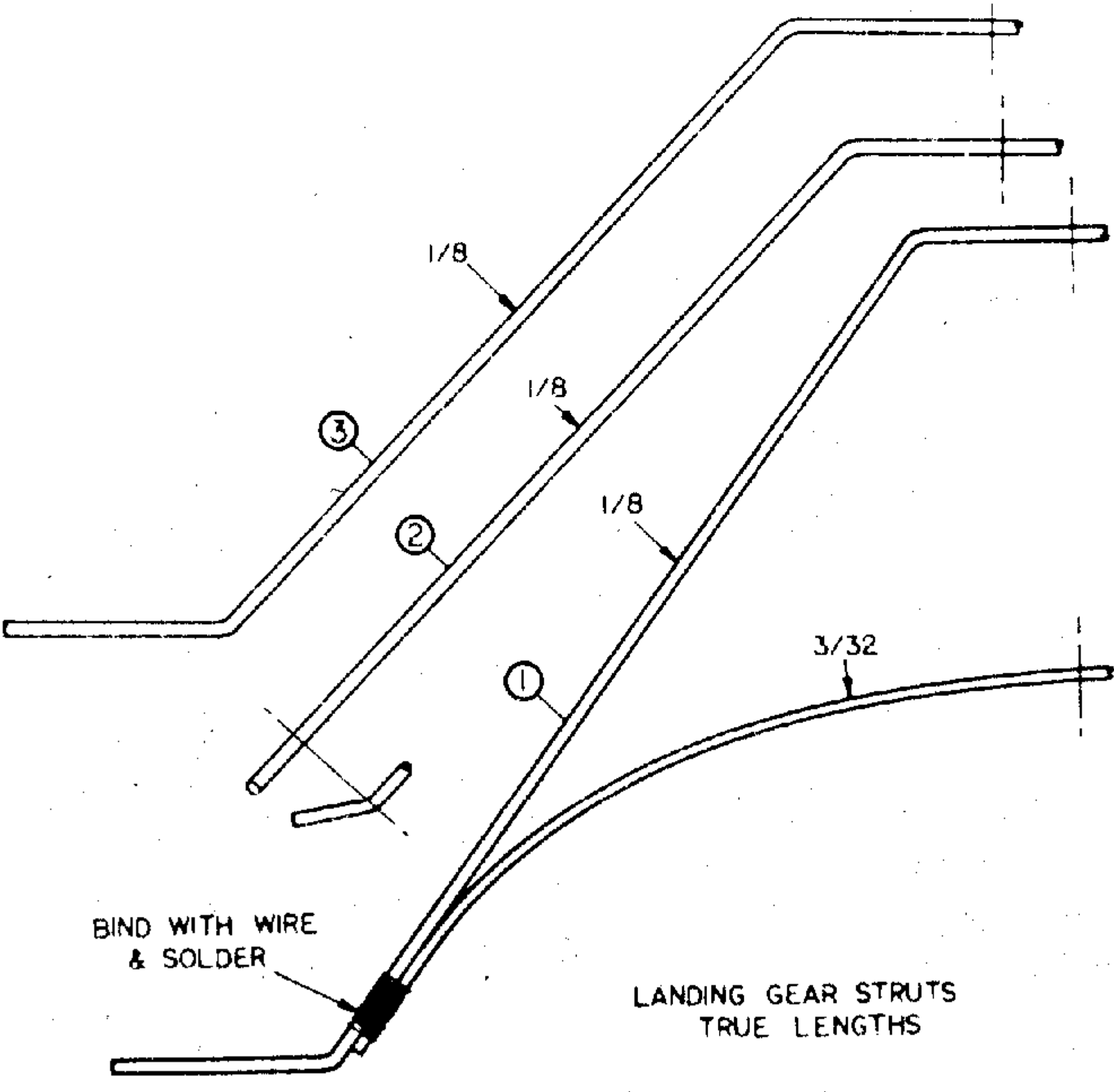
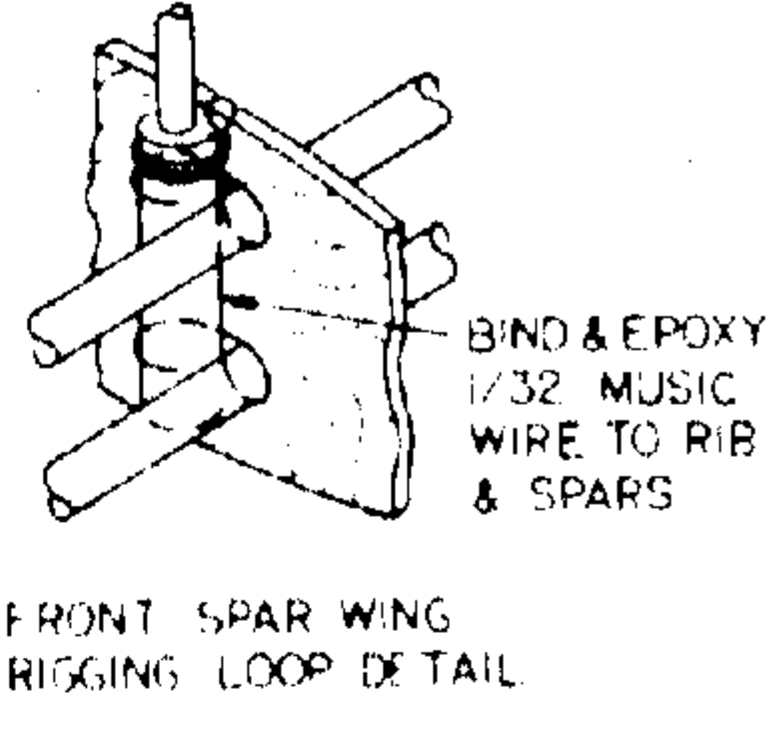
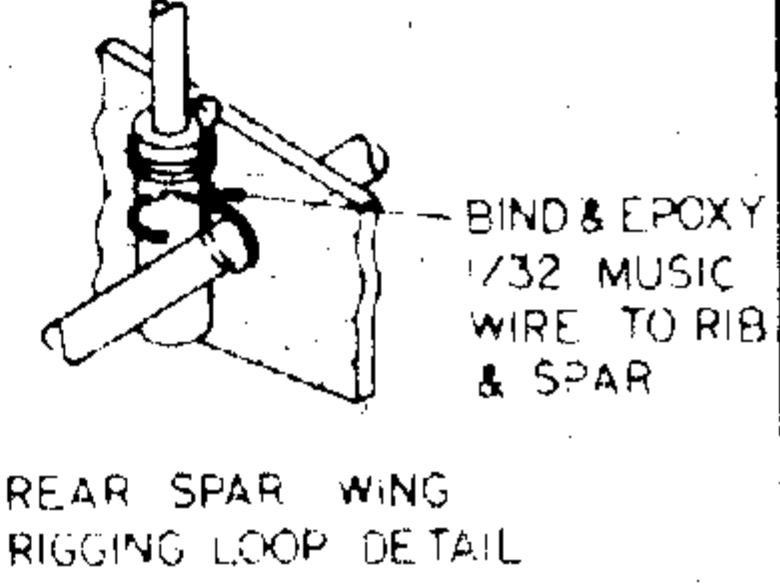

# Boeing B & W 1916

SCALE 0 1 2 3 4 5 6 7 8 9 10