

Piper Cherokee

designed by Jack Headley

CHAMFER.

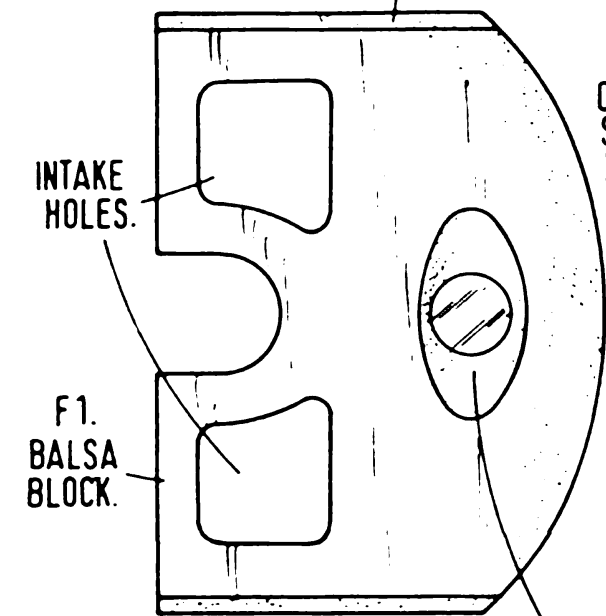

DEPRESSION WITH DISC OF ALUMN. FOIL AS LANDING LAMP.

A 38" SPAN R/C SCALE MODEL FOR .049 CU. IN. (0.8 CC)

plan value 7/6

