

**FUSELAGE ASSEMBLY**

**STEP 1**  
To prevent parts from sticking, spread Saran Wrap or similar kitchen film over Plan. So that construction can proceed rapidly once assembly has been started, make the following sub-assemblies: Cement the two bulkheads 3 together to form a double thickness and do likewise with both 4 & 5 and cement 6 to 7, then drill 1/8 holes at punch marks. The four punch marks adjoining

the large hole in Bulkhead 3, have been set up for the Aluminum Motor Mounts to fit the Buys 35. If any other engine is to be used, spacing of holes must be altered to suit. Assemble Plywood doublers to ribs, using Part Numbers as shown in sketches. Be sure to make a right hand and left hand of each assembly as shown. Cement 9, 10 & 11 together to form fin.

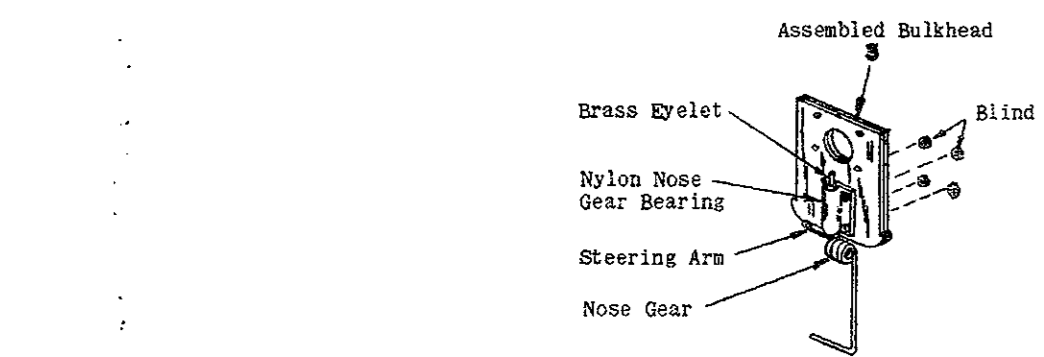

**STEERABLE NOSE GEAR ASSEMBLY**

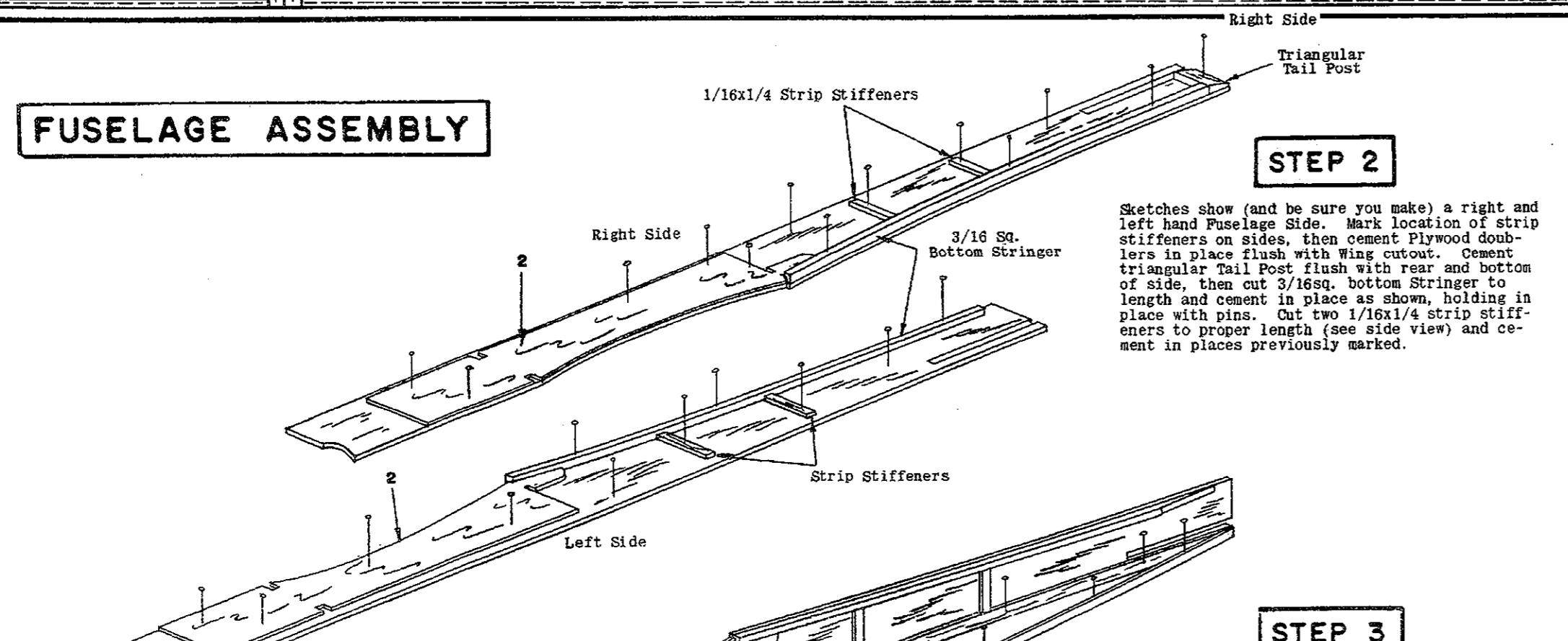

**STEP 2**

Sketches show (and be sure you make) a right and left hand Fuselage Side. Mark location of strip stiffeners on sides then cement Plywood doublers in place flush with wing cutout. Cement triangular Tail Post flush with rear and bottom of side, then cut 5/16sq. bottom Stringer to length and cement in place as shown, holding in place with pins. Cut two 1/16x1/4 strip stiffeners to proper length (see side view) and cement in places previously marked.

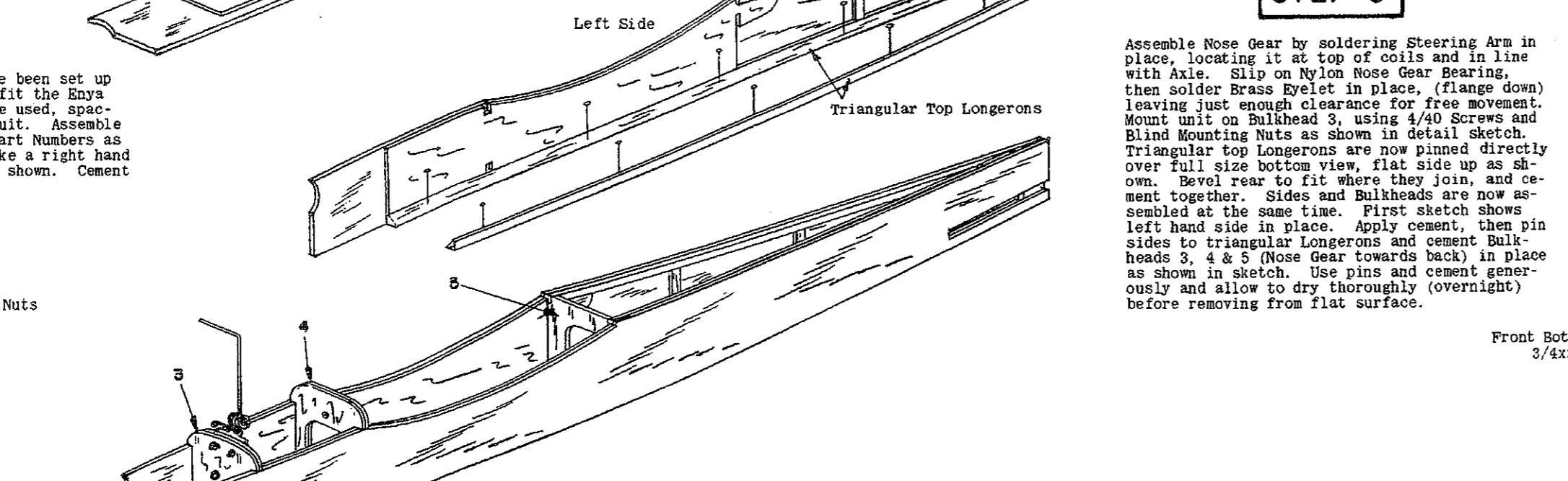

**STEP 3**

Assemble Nose gear by soldering Steering Arm in place, locating it at top of coiled and in line with axle. Slip on Nylon Nose Gear Bearings, then solder Brass Eyelet in place. (Flange does) leaving just enough clearance for free movement. Mount unit on Bulkhead 3, using 4/40 Screws and Blind Mounting Nuts as shown in detail sketch. Triangular top Longerons are now pinned directly over full size bottom view, flat side up as shown. Bevel rear to fit where they join, and cement together. Sides and Bulkheads are now assembled at the same time. First sketch shows left hand side in place. Apply cement, then pin sides to triangular Longerons and cement Bulkheads 3, 4 & 5 (Nose gear towards back) in place as shown in sketch. Use pins and cement generously and allow to dry thoroughly (overnight) before running from flat surface.

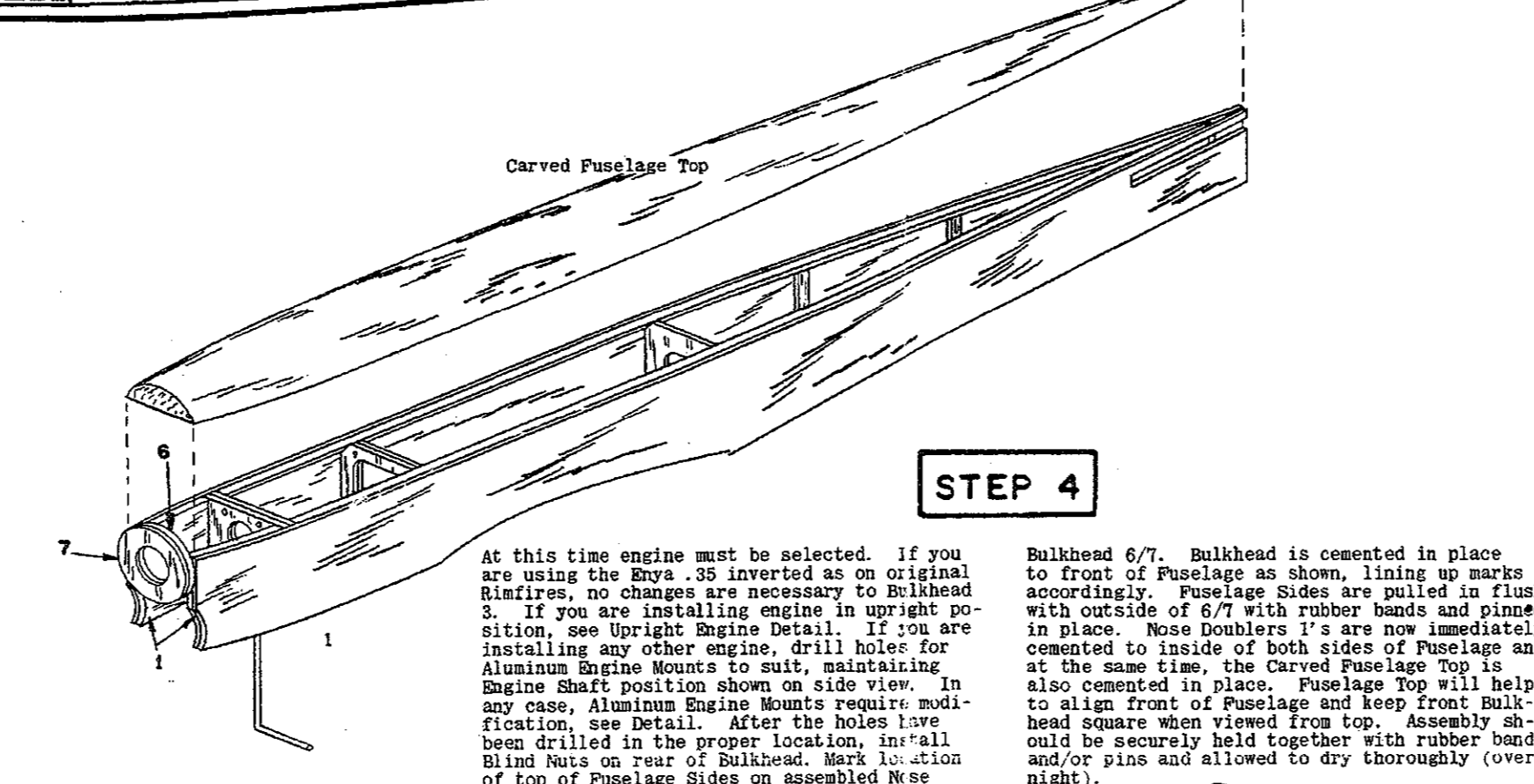

**STEP 4**

At this time engine must be selected. If you are using the Buys 35 inverted as on original Rimfire, no changes are necessary to Bulkhead 3. If you are installing engine in upright position, see Upright Engine Detail. If you are installing any other engine, drill holes for Aluminum Engine Mounts to suit, maintaining Engine Shaft position shown on side view. In any case, Aluminum Engine Mounts require modification, see detail. After the holes have been drilled in the proper location, install Blind Nuts on rear of Bulkhead. Mark location of top of Fuselage Sides on assembled base.

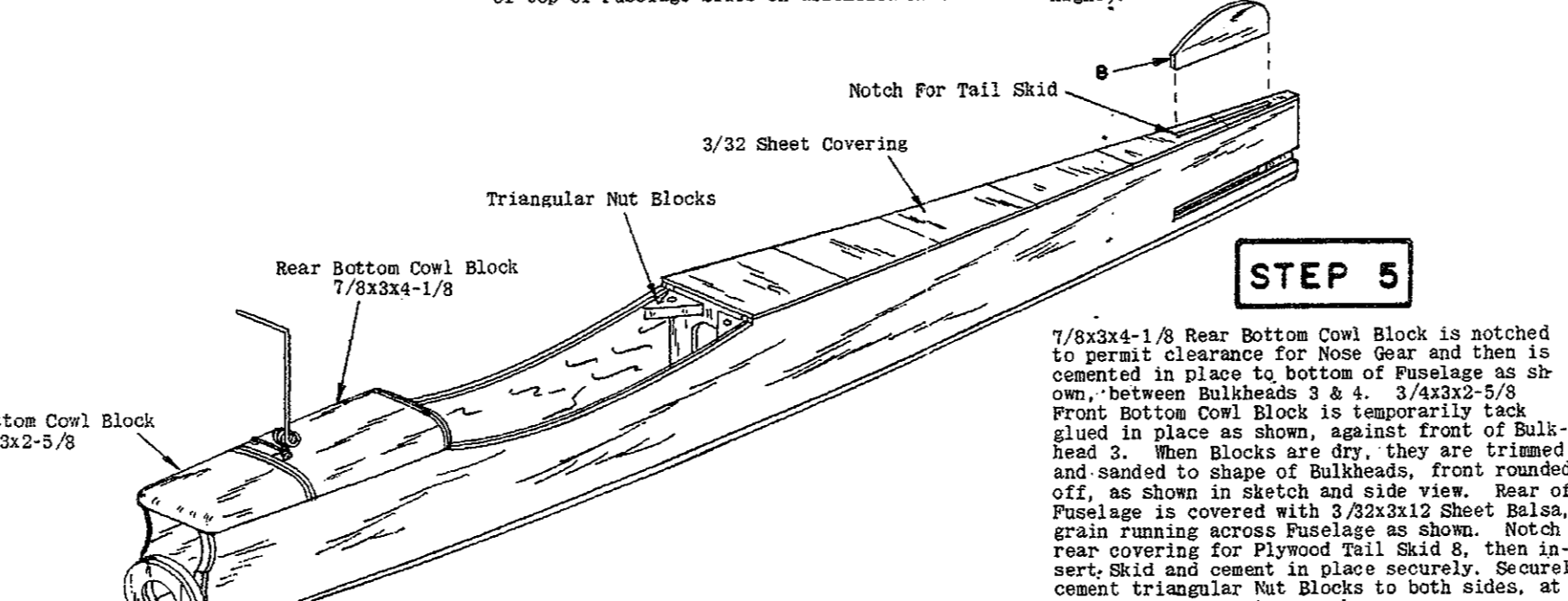

**STEP 5**

7/8x3/4-1/8 Rear Bottom Cowling Block is notched to permit clearance for Nose gear and then is cemented in place to bottom of Fuselage, as shown, between Bulkheads 3 & 4. 3/4x3/2-3/8 Front Bottom Cowling Block is temporarily tack glued in place as shown, against front of Bulkhead 3. When blocks are dry, they are trimmed and sanded to shape of Bulkheads, front rounded off, as shown in sketch and side view. Rear of Fuselage is covered with 3/32x3/2 Sheet Balsa, grain running across Fuselage as shown. Notch rear covering for Plywood Tail Skid 8, then insert and cement in place securely. Securely cement triangular Nut Blocks to both sides, at rear of Wing cutouts, as shown.

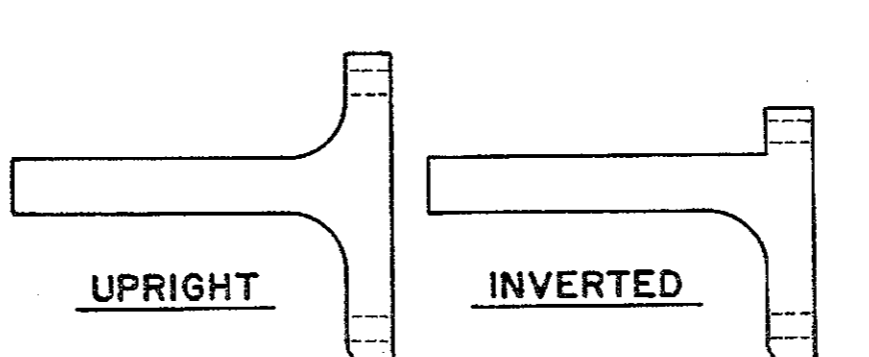

**ENGINE MOUNT MODIFICATION**

Aluminum Engine Mounts provided in kit must be modified in order to keep the slim jet appearance of the Rimfire Nose. Full size drawings above show modification required for inverted as well as upright engine installation. It is possible that modifications may vary to suit different Engines. Cut off Mount as shown and re-drill 1/8 installation hole.

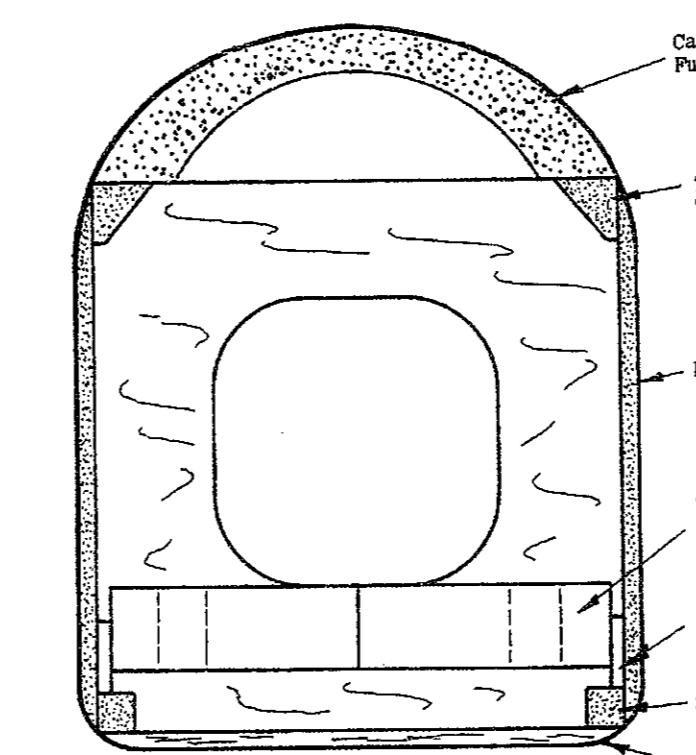

**TYPICAL CROSS-SECTION AT BULKHEAD 5**

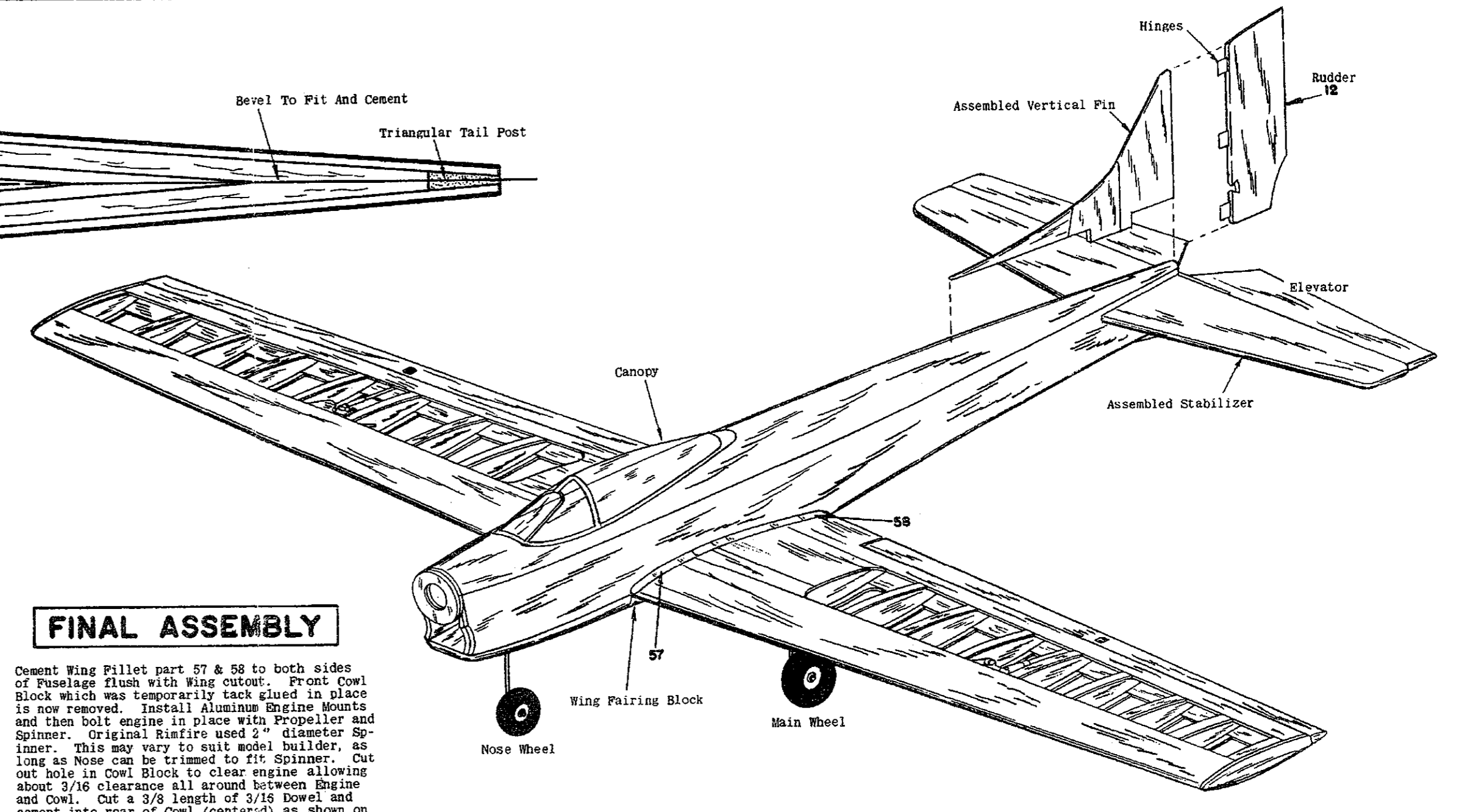

**FINAL ASSEMBLY**

Cement Wing Pillot part 57 & 58 to both sides of Fuselage flush with wing cutout. Front Cowling Block which was temporarily tack glued in place is now removed. Install Aluminum Engine Mounts and then bolt engine in place with Propeller and Spinner. Original Rimfire used 1" diameter Spinner. This may vary to suit model builder, as long as Nose can be trimmed to fit Spinner. Cut out hole in Cowling Block to clear engine allowing about 3/8 clearance all around between Buys and Cowling. Cut a 3/8 length of 3/16 Dowel and cement into rear of Cowling (centered) as shown on side view. Locate and drill 3/16 hole in Bulkhead 3 to receive it. Front of Cowling is secured with #2 Tap Screws, screwed into hardwood Block cut from 1/4x3/8 strip, and cement to each side as shown. Drill tiny holes in Blocks to prevent splitting from Screw. Since Fuselage is rounded off and sanded smooth as shown in sketch and typical cross section. Triangular upper Longerons provide necessary material so that top of Fuselage may be rounded gracefully into cut-off to pleasing shape. Nose should flow smoothly into round spinner shape as shown, and fillets shaped off smoothly. Cement 57 & 58 securely into slot in Fuselage. Place rear of Fin at rear of Fuselage and mark tab location (on bottom of Fin) on Carved Top. Drill 3/16 holes at front and back mark (in center of Fuselage), then complete Fin slot by trimming out between holes. Fin is now cemented to top of Fuselage, into slot. Rudder 12 is sanded to tapered section, shown on side view, then mounted to fin and Fuselage with Poly Wings (see detail). Locate Wing mounting holes as follows: Install Nylon Screws completely into Nut Blocks. Place Wing in position, inserting lower into hole in Bulkhead. Place carbon paper between Wing and Nylon Bolts and press firmly thus leaving an impression. Remove Wing and drill slightly oversized 1/4" holes (no Screw case through center) through. Trailing Edge at marked locations. Remove Nylon Screws, then re-mount Wing to check hole location. Wing Fairing Block provided shaped to match airfoil. It is now cemented to front of Wing (Wing) at Fuselage. When dry, shape to blend smoothly into Fuselage. Model is now covered with material of your choice (not included in Kit). For realistic appearance, area cov-

ered by Canopy can be painted dark gray and treated as another engine, including Pilot, head, etc., nose of which is provided in Kit. Model is now painted to suit individual taste. Box wrap shows original color scheme and location of details. Wire Landing gear struts are now installed by inserting Spurr thru hole in Landing gear blocks. Secure with Metal Plates and #4 Tap Screws. Install both Struts shown on Wing Step 5. Wheels and radio equipment (not included in Kit) are now installed in accordance with manufacturer's instructions. Typical position of radio equipment is shown on Plan as is the Fuselage Linkage. Linkage uses 1/8x1/8 17-78 Balsa strips provided with 1/8 Wire Spur cemented and bound to front, and threaded Clevis Shaft for rear so that Nylon Clevis can be installed and adjusted. Side view shows location and installation of 6 oz. Polio brand fuel tank, may similar size and type may be used. Battery pack is located under fuel tank as shown. Entire compartment is stuffed with foam. IT IS IMPORTANT THAT MODEL BALANCE AT POINT SHOWN BY ARROW! Radio components may be shifted forward or aft to achieve balance at that point. IF NECESSARY, ADD WEIGHT TO FRONT OR BACK SINCE MODEL MUST NOT BE FLOWN UNTIL THIS BALANCE IS ACHIEVED. Main Wheels are 2-1/2" and Nose Wheel is 2". This is optional, however relative sizes should be maintained. We would welcome your comments on this Rimfire Kit and its flight performance. Address correspondence to Sterling Models, Inc. - Wister & Belfield Ave. - Philadelphia, Pa. 19144 U.S.A. - Atlas Engineering Dept. Good Luck -- Much Fun -- and Happy Landings.

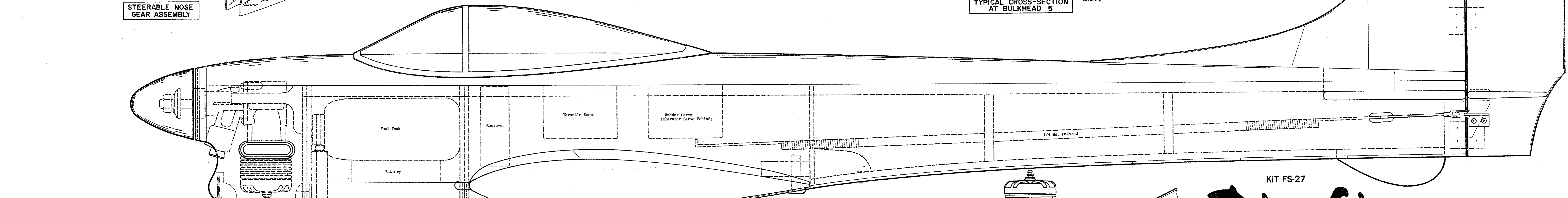

**SIDE VIEW**

RIMFIRE MUST BALANCE HERE BEFORE FLIGHT

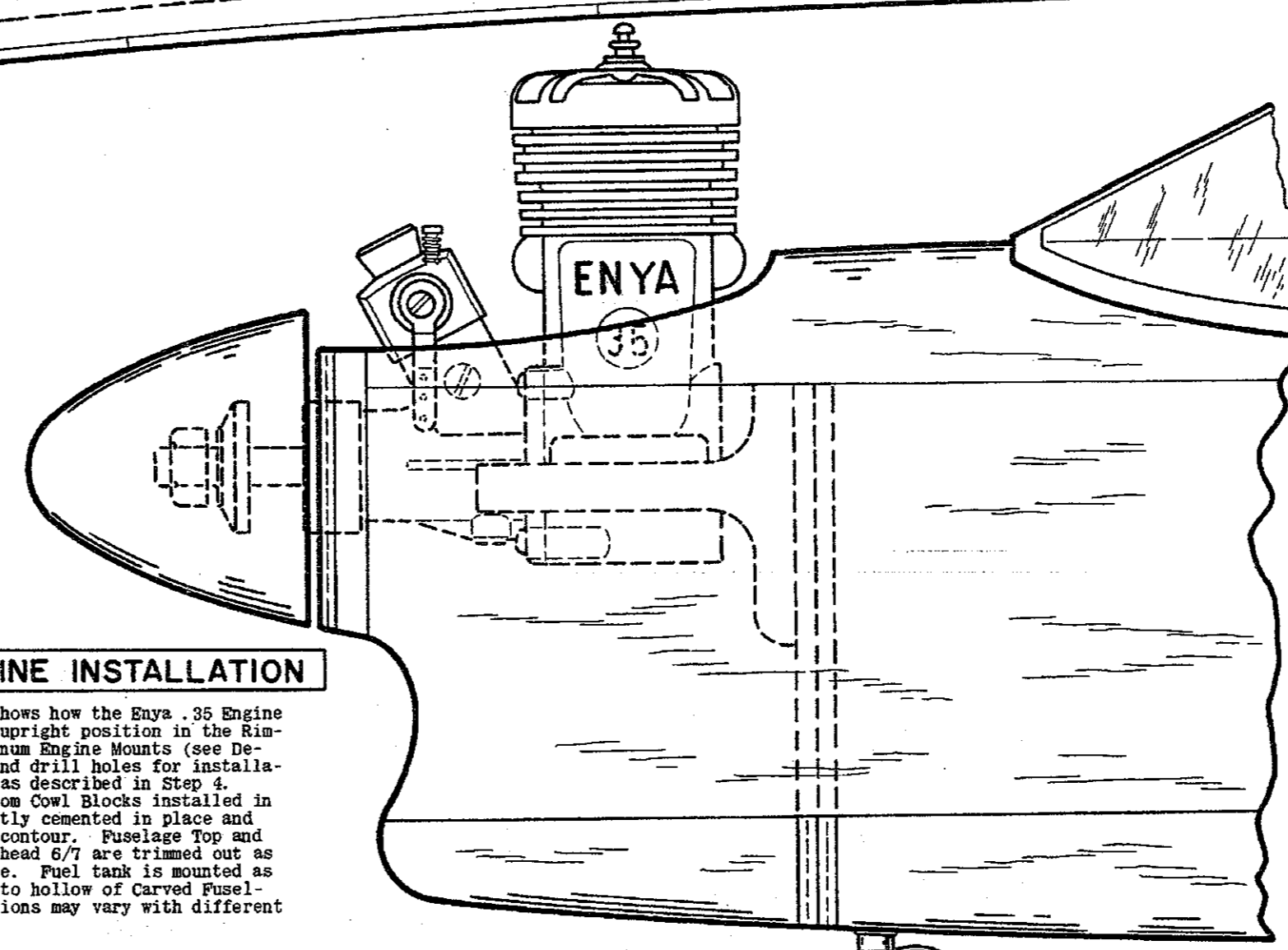

**UPRIGHT ENGINE INSTALLATION**

Full-size drawing shows how the Buys 35 Engine is installed in an upright position in the Rimfire. Modify Aluminum Engine Mounts (see Detail) then locate and drill holes for installation on Bulkhead 3 as described in Step 4. Front and Rear Bottom Cowling installed in Step 5 are permanently cemented in place and sanded to Fuselage contour. Fuselage Top and assembled Nose Bulkhead 6/7 are trimmed out as shown to suit Engine. Fuel tank is mounted as high as possible into hollow of Carved Fuselage Top. Installations may vary with different Engines.

**KIT FS-27**

**Rimfire**

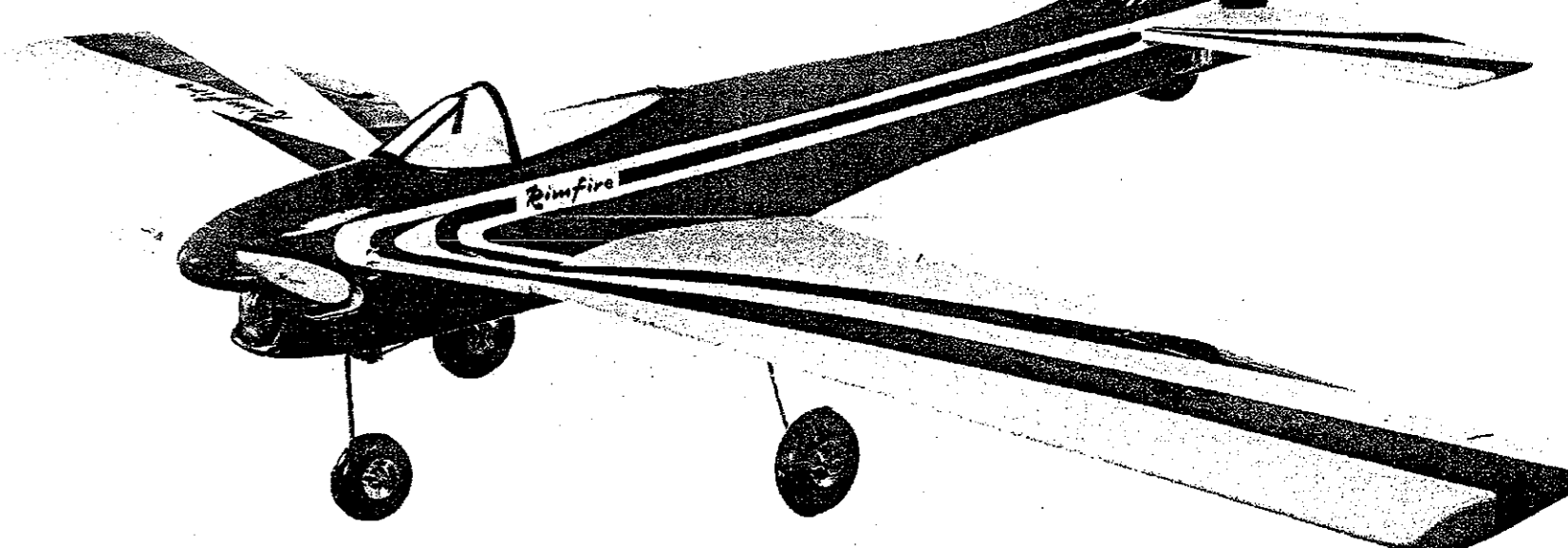

SPAN: 56" AREA: 525 sq. in. WEIGHT: 2 1/2 lbs. (Less R/C) ENGINE: .29 to .51

**Sterling MODELS INC.**  
PHILA., PA. 19144, USA

