

**FINAL ASSEMBLY**

Assemble & trim all plastic parts, see detail note. Cement plastic cowl in place to #5 bulkhead, followed by machine gun-cowl, as shown. Cement stabilizer to top rear of fuselage against bulkhead 11. Cement rudder, vertically, to rear & top of fuselage. Complete rear top corners of fuselage by cementing 53's in place as shown. Cement lower wing in place on bottom of fuselage as shown so that center ribs are directly under #4 fuselage center keel. Hold with pins and check that both tips are same height from flat surface. Allow lower wing to dry thoroughly before proceeding. Trim out notches in all strut gussets in both wings. Make strut assemblies as described in detail note. Securely cement bottom of wing struts (not 50's) into notches in lower wing. CAUTION: Push down firmly until 50's rest on wing for proper incidence, otherwise model will fly. When struts are dry, put top wing into position on struts, pressing down firmly until wing is seated on 51's. CAUTION: Wing must rest on 51's for proper incidence, otherwise model will not fly. Cement top of struts only. Center struts 52's are cemented on each side. Top fits into notch in 42's & 43's; bottom rests on stringer below gussets 16 & 17. Complete bottom of fuselage by cementing 56's to corners on both sides, from bulkhead 13 to rear of lower wing. Cement 55 to center keel #4 (at bulkhead 6) back to rear of wing. Cement 57's on both sides of fuselage against rear of 6 & inside of 56, flush with bottom. When dry, this section is covered with silkspan tissue, trimming out notch in 57's. Make double layer spreader bar by cementing two 58's together, first cutting a slot for landing gear wire at crease mark (in top 58 only), as shown. When dry, round off as shown on side view & cement securely in place, inserting wire into notches. Round off



**PLASTIC PARTS DETAIL**

For best results, follow instructions carefully. **COWL:** Cut from sheet leaving about 1/16 of material for trim. Excess material may be trimmed with knife and sandpaper. Engine cowl is placed on bulkhead 5 for support while sanding. **MACHINE GUN-COWL:** Cut from sheet. Trim to fit and cement to top of fuselage from 5 to 6. **PILOT:** Leave about 1/8 excess material when cutting halves from sheet. Carefully trim out slots about 1/32" wide on top bottom & ends, right to the edge of the pilot as shown. This will permit accurate assembly. Cement halves together, lining up

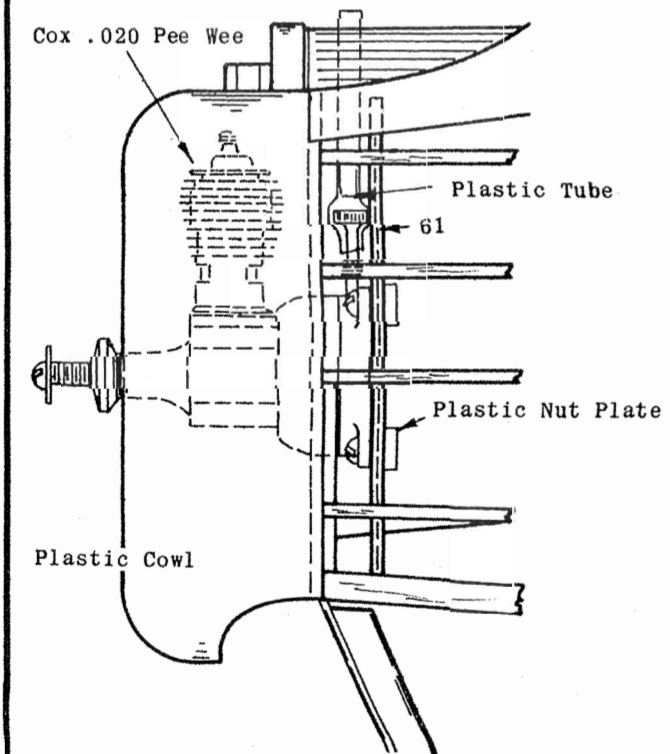

**ENGINE INSTALLATION**

Engine is used if model is being built for control line, free-flight or radio. Engine & installation material not provided in kit. Drawing shows installation of Cox .020 Pee Wee Engine; however, any other similar engine may be used. Entire fuselage, on front back to #6 should be covered with 1/32" or 1/16" sheet Balsa. Top is cut out for engine clearance. Engine is installed on die cut 1/16" d. holes in kit. Carefully drill 1/8" holes at punch marks. Mount engine to firewall with #2 nuts & bolts, tightening nuts securely. Cut plastic nut plates from molded sheet & cement to back of firewall over nuts, drilling hole so that bolts can protrude. Use cement generously. Nut plate keeps nuts from turning, so that engine can be removed by just unscrewing bolts. When dry, remove engine. Securely cement firewall in position shown. Cut molded machine gun and engine cowl from plastic sheet as described in Detail Note. Cement engine cowl to front of fuselage on 5; cement machine gun cowl to top of fuselage from 5 to 6. Trim engine cowl and 5 to clear engine. Drill three holes in machine gun-cowl, in position indicated by dotted line on firewall drawing, for needle valve extension & plastic fuel tubing. Remove cowl then add a 1-1/4 length of 1/16 I.D. plastic tubing to each tube adjoining needle valve. Cut top of tubing at angle facing forward for easy admission of air stream. Make needle valve extension by cutting 3/4" length of 1/8 I.D. tubing and forcing over head of needle valve. Cut a 1" length of 1/8 d. d. and insert into tubing. This should be tight fit. Needle valve can now be adjusted without removing cowl. Cowl is cemented or held in place with small wood screws. If it becomes necessary to remove engine for any reason, break cement joint at cowl. Engine is then reinstalled and cowl reassembled or screwed back in position.

**CAUTION:**  
Do not fly control line models in the vicinity of electric power lines!

**CONTROL LINE INSTALLATION**

Materials required are not provided in kit. #62 Bell crank platform is securely cemented across 12's against rear of 6. Fill in area between 5 & 7, from side keel 12 to stringer above it, with scrap 1/16 sheet Balsa flush with outside of frame. Fill in area from 11 to rear between 12 & stringer above it in same manner. Cut 1/8 slot in rear for control rod as shown. Cut two 18" lengths of lead-out lines & fasten them to bell crank. Push rods is 1/16 wire at least 14" long. Make a right angle bend at one end. Place in fuselage, insert in bell crank, & mount assembly to plywood platform as described in instructions that come with bell crank. Cut stabilizer in half thru wide main spar as indicated by dotted lines. Round edges and install control horn at location shown on drawing, then insert together with cloth hinges shown. Cement stabilizer horizontally into slot in 2 against 11. Tape elevators in neutral position (in line with stabilizer, neither up or down). Make right angle bend at rear end of control rod at precisely the location of hole in elevator horn, with bell crank in neutral position as shown. Trim off excess and insert into horn. Solder washer on end to prevent rod from coming off. Controls are now in neutral position and must work freely and easily. Cut rudder from fin on dotted lines shown on full size drawing. Cement rudder back on fin with rear of rudder turned at angle 1/2" towards outside of circle flow, as shown. Clear for elevator movement and cement vertically to top of 2 and against rear of fuselage. Assemble wings to fuselage as described in Final Assembly Detail. #50 is wing guide. Drill holes indicated, then cement securely to bottom wing against struts as shown. Reinforce holes for lines in fuselage and wing guide with washers or eyelets. Thread lines thru holes in wing guide & tie loops in end of lines at least 3" past wing tip. Lines must be of equal length when elevator is in neutral position. Control system must operate freely and easily. CAUTION: Model must balance (or slightly nose down) at point shown on side view. If necessary, add weight. Use regular 1/2A control lines and handle when flying your British Sopwith Camel. **GOOD LUCK!!! GOOD FLYING!!!!**

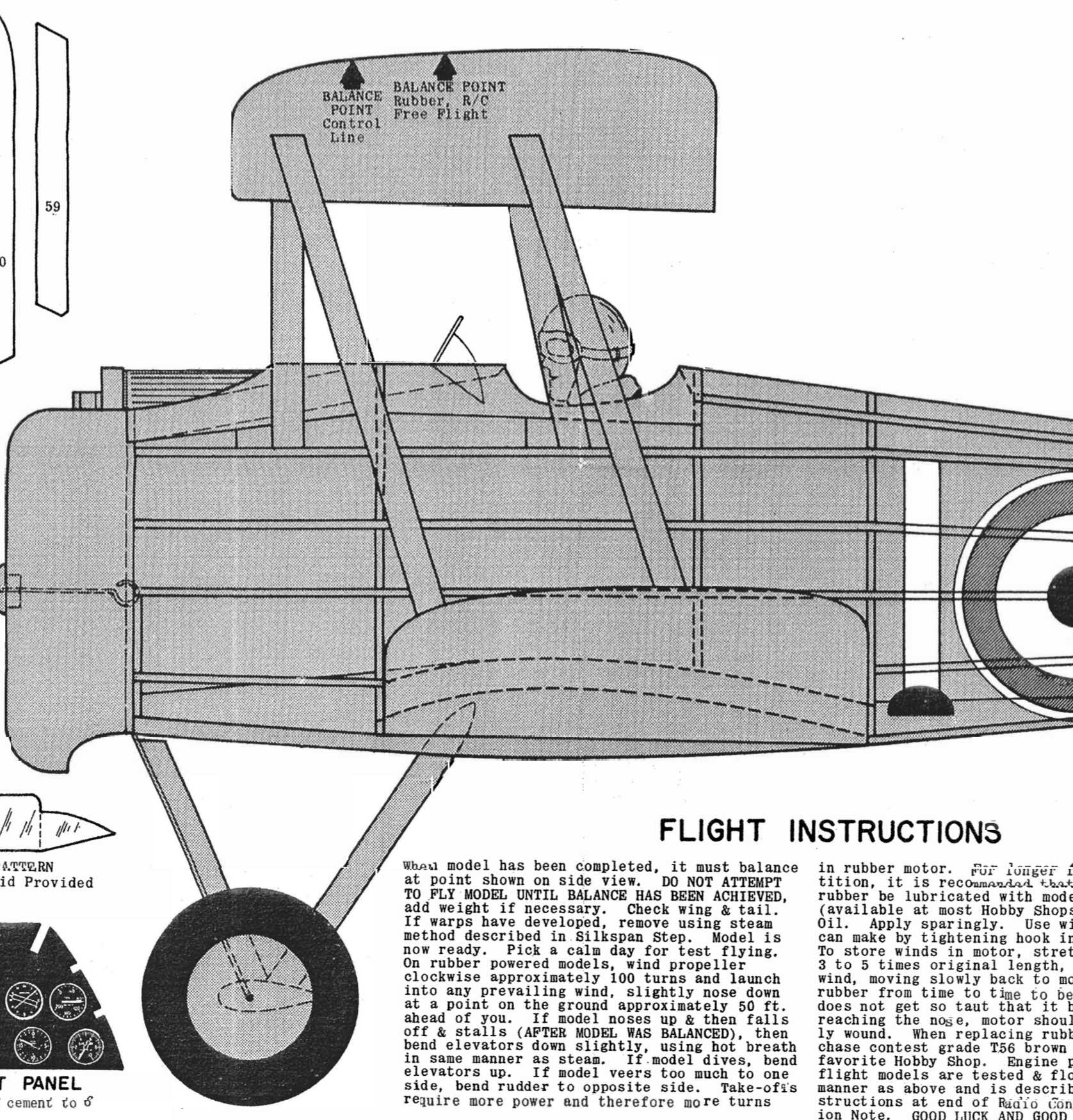
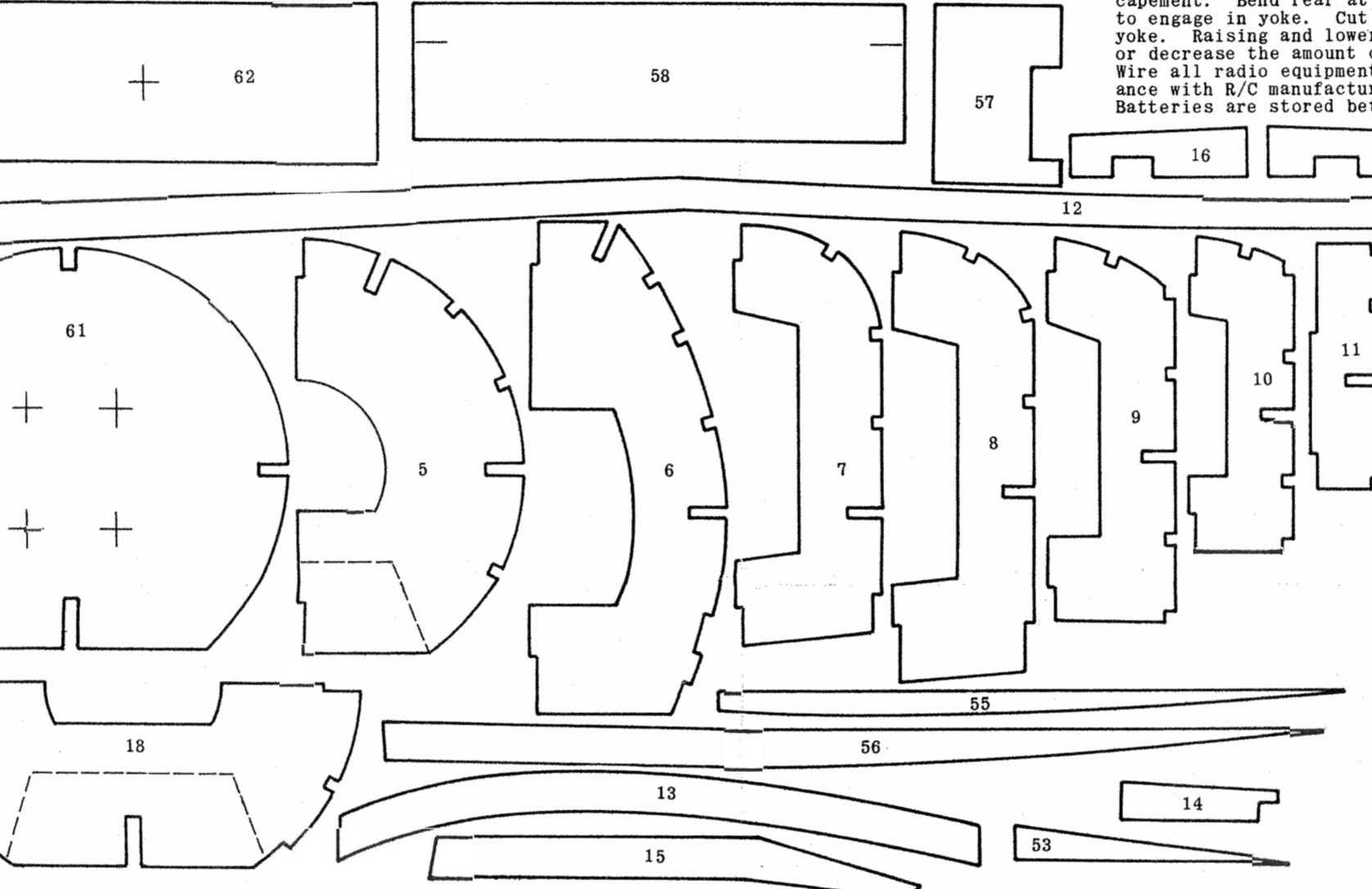

**SILKSPAN TISSUE COVERING**

The finest grade wet strength silkspan tissue provided in this kit permits covering of compound curves without wrinkling when moistened with water before applying to frame. Tissue shrinks when dry, to a light smooth surface. Follow directions for a smoothly covered, warp-free flying model. Use clear dope to attach tissue as follows: Apply a light coat to the outside edges of area to be covered, and allow it to dry. Cut tissue to shape needed, plus 1/4" over size. Place tissue on flat surface and dampen with moistened cloth. Apply a second coat of clear dope on frame, then place moistened tissue on frame. Pull tissue gently with fingers, working out all wrinkles. **WHEN COVERING WINGS AND TAIL SURFACES, PIN FRAMEWORK TO FLAT SURFACE TO PREVENT WARPS AS TISSUE DRIES.** Cut out any wrinkled areas (bound by nearest framework) and re-cover. Apply 2 or 3 coats of clear dope, cut 50/50 with thinner to wings and tail surfaces before assembling, pinning on flat surface to prevent warps. **COVER BOTTOM WING FIRST:** Cover entire bottom in one piece. Cover top in two pieces from dihedral joint to tip ribs 39. Cover tips with separate pieces. On control line models, add 1/2 oz. weight to lower wing tip on outside of circle flow (see C/L detail). **COVER TOP WING NEXT:** Top wing is covered in same manner as bottom wing. **COVER STABILIZER AND RUDDER NEXT:** Cover both sides of each in one piece. **COVER FUSELAGE NEXT:** Cover sides front to rear, from corner stringers (top to bottom). Cover top rear in one piece, from rear of cockpit back. After structure under bottom wing is completed, as described in Final Assembly, cover bottom from 5 to rear in one piece. Remove tissue from cutout in 57's, thus allowing rear landing gear struts to move. Put shock absorbing action. Cut cockpit cover from stiff paper, using pattern provided, and cement in place. Apply 4 coats of thinned dope to tissue covering on fuselage. Check wings & tail surfaces for warps before assembly. Warps can be removed by holding over steam from boiling kettle, and twisting gently in opposite direction. Check again when cool.

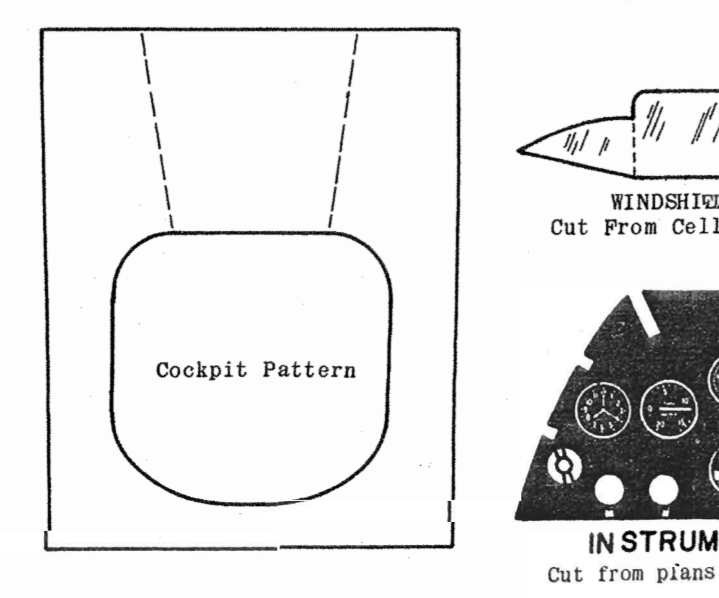

**HINGE DETAIL**

Use cloth tape for hinges. Cement only on top and bottom, alternating hinges as shown above. Keep cement out of hinged area between sections.

**RADIO CONTROL INSTALLATION**

Test models used, and drawing shows Citizen-Ship MDL Receiver, SE2 Escapement, used with SPX Transmitter. This equipment and other material necessary is not provided in kit. Radio is installed after lower wing is cemented in place, as described in Final Assembly. Access to R/C equipment is thru removable belly block fitted to bottom wing. Cut out the 1/16 sq. spar across center section. Fit soft Balsa belly block between 6 & 8, and shape to fit fuselage as shown in sketch. Bend hooks from pins and cement on either side as shown. Rubber band across hooks keeps block in place. Cut rudder apart at location shown by dotted lines, and assemble with cloth hinges. Bend wire yoke from 1/32 wire, install on rudder with 2/56 nut & bolt. Cut escapement base from 1/16 plywood and mount escapement, then cement to front of bulkhead 7 as shown. Cut a 3/32 slot in rear of fuselage for torque rod. Using a length of 1/16 wire, at least 18" long, insert thru hole, then bend U in front of wire yoke. Raising and lowering yoke will increase or decrease the amount of rudder movement. Wire all radio equipment together in accordance with R/C manufacturer's instructions. Batteries are stored between 5 & 6. After

they have been soldered, line compartment with foam rubber and place in fuselage. Bend small wire hook for antenna attachment and cement to front of rudder. W39 receiver in foam rubber and place in fuselage behind bulkhead #6. Bring antenna out of cockpit & fasten to hook with rubber band as shown. When model has been completely finished, it must balance as shown on side view. If necessary, add weight, but DO NOT ATTEMPT TO FLY UNTIL BALANCE HAS BEEN ACHIEVED. Check wings and tail for warps. If any have developed, remove with steam method as described in covering instructions. Wait for calm weather for test flights. Field test R/C equipment before flying, as described in manufacturer's instructions. Start engine and THROTTLE DOWN TO LOW SPEED, then launch model with nose pointed slightly down at a point 50 or 60 ft. in front of you, and release at approximate flying speed. Model should fly in straight line and either maintain or slightly lose altitude. If model turns to either side, rudder or engine may be offset to opposite side to achieve a straight flight, which is how it should glide & fly. If model glides well, but stalls under power, point front of engine down (down thrust) by placing shim under top of fuel tank. Increase engine RPM as adjustments are made, checking R/C controls before each flight. **GOOD LUCK & GOOD FLYING!!!!**

**DIE CUT PART NOTE**

Die cut parts used in construction are given full size on wing and tail plan or layouts on left and below. Rib cross sections can be used as rib patterns. This enables you to duplicate any part for any reason. Die cut parts in sheet (as in kit) are available from factory as replacements.

**SOPWITH CAMEL SPECIFICATIONS AND COLOR SCHEME**

- Wing Span - 28 Ft. 0 In.
- Chord of Wing - 4 Ft. 6 In.
- Length - 18 Ft. 9 In.
- Height - 8 Ft. 6 In.
- Weight Empty - 929 Lbs.
- Weight Loaded - 1453 Lbs.
- Top Speed - 115 M.P.H.
- Ceiling - 19,000 Ft.
- Fuel Capacity - 37 Gal.
- Climb - 950 Ft. P.M.

See box lid for authentic color scheme, decals for which are provided in kit. Color scheme varied to some extent, to preference of individual Squadron or pilot. Generally speaking: Fuselage, fin, struts, upper surfaces of wings & horizontal stabilizer, wheel discs & engine cowls were solid khaki. (Some Camels had polished or burnished engine cowls); all lower surfaces of wings & horizontal stabilizer were buff; all Squadron & special service markings, letterings were white; training & home defense versions were all silver. It is recommended that a minimum of color dope be used.

**FLIGHT INSTRUCTIONS**

When model has been completed, it must balance at point shown on side view. DO NOT ATTEMPT TO FLY MODEL UNTIL BALANCE HAS BEEN ACHIEVED, add weight if necessary. Check wing & tail. If warps have developed, remove using steam method described in Silkspan Step. Model is now ready. Pick a calm day for test flying. On rubber powered models, wind propeller clockwise approximately 100 turns and launch into any prevailing wind, slightly nose down at a point on the ground approximately 50 ft. ahead of you. If model noses up & then falls off & stalls (AFTER MODEL WAS BALANCED), then bend elevators down slightly, using hot breath in same manner as steam. If model dives, bend elevators up. If model veers too much to one side, bend rudder to opposite side. Take-offs require more power and therefore more turns

in rubber motor. For longer flights & competition, it is recommended that the loop of rubber be lubricated with model lubricant (available at most Hobby Shops) or with Castor Oil. Apply sparingly. Use winder which you can make by tightening hook into hand drill. To store winds in motor, stretch rubber out 3 to 5 times original length, then proceed to wind, moving slowly back to model, peeling rubber from time to time to be certain it does not get so taut that it breaks. Upon reaching the nose, motor should be completely wound. When replacing rubber motor, purchase contest grade T56 brown rubber at your favorite Hobby Shop. Engine powered free-flight models are tested & flown in same basic manner as above and is described in flight instructions at end of Radio Control Installation Note. **GOOD LUCK AND GOOD FLYING!!!!**



**SOPWITH CAMEL**

**Sterling**  
MODELS  
PHILA. PA. USA

KIT A26,  
WING SPAN 24"

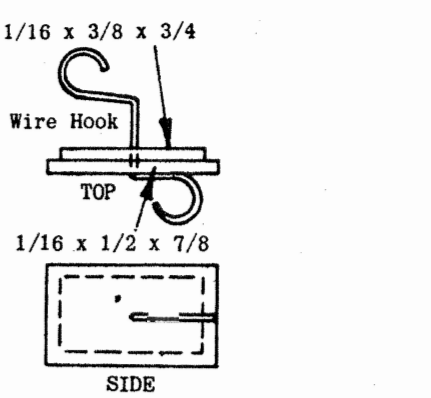

**R.C. WINDING HOOK DOOR**

Inset 1/16 sheet in area between 10 & 11, from side keel to 2nd stringer above it, (cut out first stringer). When dry, cut out a rectangular hole 3/8 x 3/4. Cement piece (cut out) to 1/16 x 1/2 x 7/8 (grain running cross-wise) as shown, to form door. Bend half of hook from 1/32 wire & push straight end in door -- then bend hook on other end as shown in top view. Cement hook securely to door in position shown. Place loop of rubber between escapement and hook on inside of door.

**RUDDER YOKE**

Bend from 1/32 Wire

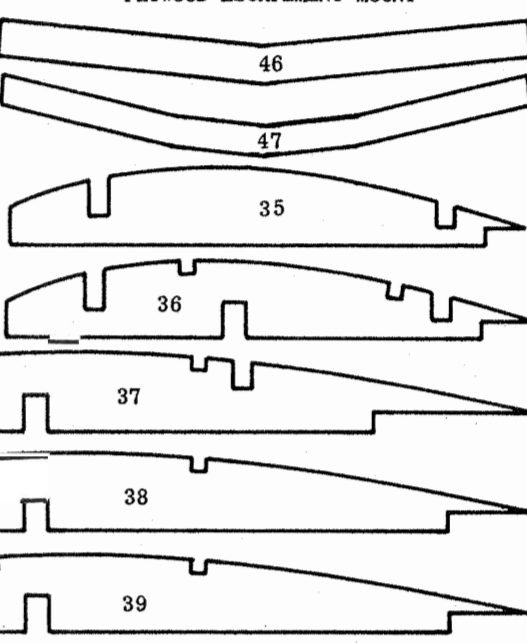
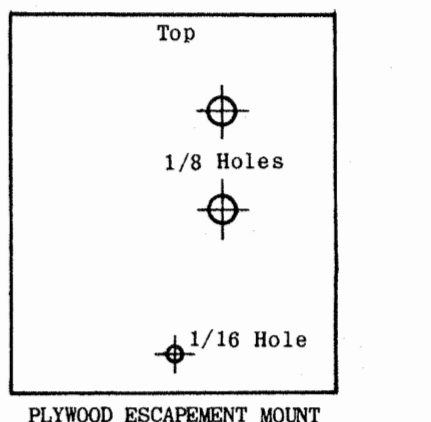

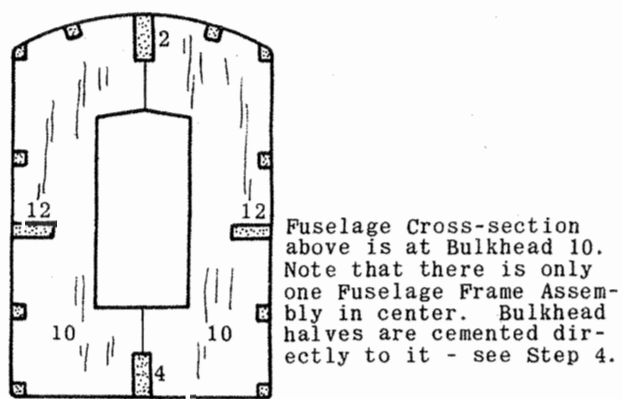
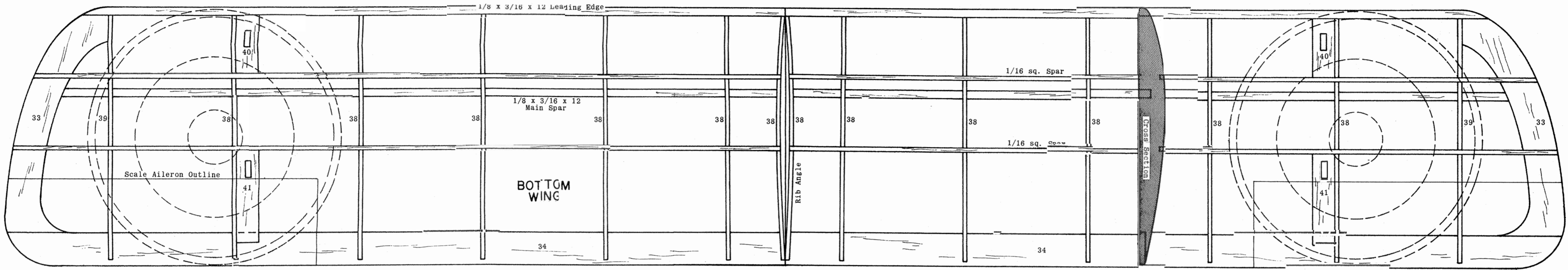
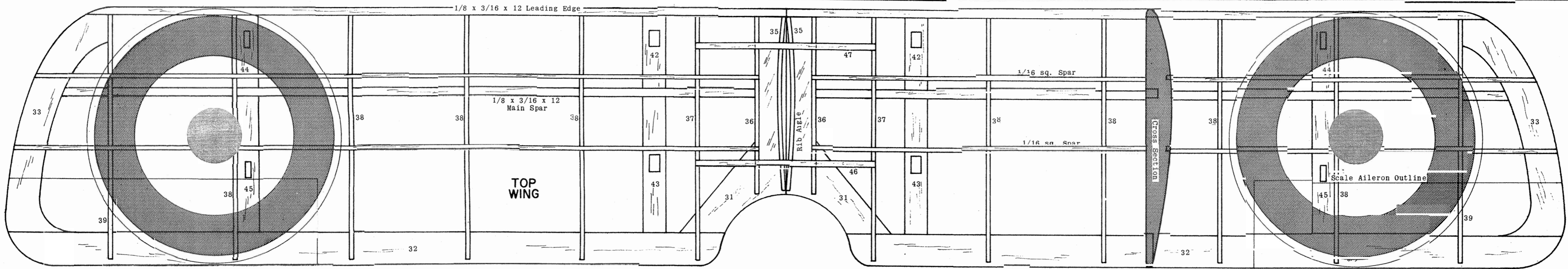

**FUSELAGE ASSEMBLY**

**STEP 1**  
Fuselage construction is started on flat surface directly over plan. Pin parts in place as shown, cementing 3 between 2 & 4 at rear.

**STEP 2**  
Cement all bulkhead halves from 5 to 11 vertically in place as shown, then add 12 which is inserted into long slots in center of bulkheads.

**STEP 3**  
Pin & cement side keel 13 into notches in corners from 6 to 8. Note 1/16 space left for corner stringer. Cement the rest of the stringers, which are 1/16 sq., into their respective notches, beveling ends to knife edge at rear. Any stringers not visible can be seen in next sketch. Cement 14 to front of bulkhead 11, between 12, and stringer above it flush with outside. Assembly should dry overnight to prevent warping or twisting. Construction of wing or tail surfaces can be started in the meantime.

**STEP 4**  
Carefully pull out pins and remove frame from flat surface. Cement opposite halves of bulkheads in place, then add 12. (Don't make another fuselage center frame assembly. Bulkhead halves are cemented to fuselage frame assembly already constructed as described in Steps 1, 2, and 3.) Landing gear provided in kit is now installed between 5 & 18. If model is to be gas engine powered, it is recommended that you obtain a piece of 1/16 dia. music wire and bend a new landing gear to exact shape of one provided in kit. Installation of both are similar, being sandwiched into cutouts marked between 5 & 18. Use cement generously -- install 13 & 14 and stringers in same manner as opposite side; then add 15's, 16's and 17's. Allow fuselage frame to dry thoroughly, then sand lightly to present a smooth surface for tissue covering, described in detail note. Bend tail skid from 1/32 wire (see side view for shape) and cement thru pin hole in 4. Cement 54 to bottom of 4 and against wire skid. See respective notes for R/C, Control Line, etc., before covering fuselage.

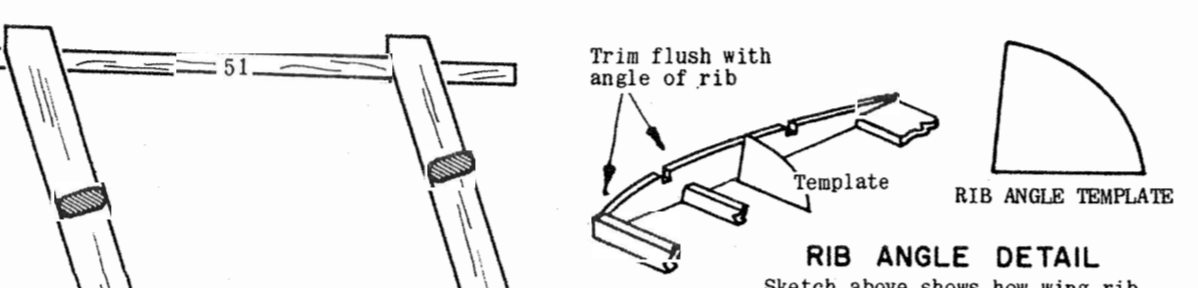
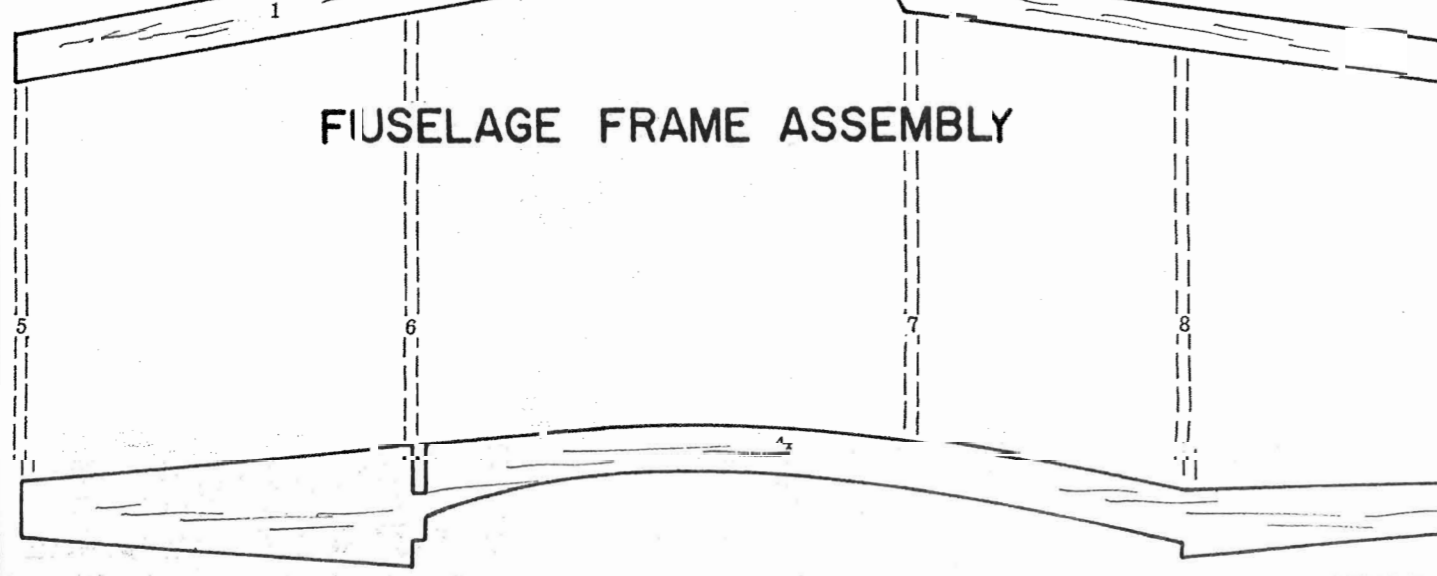
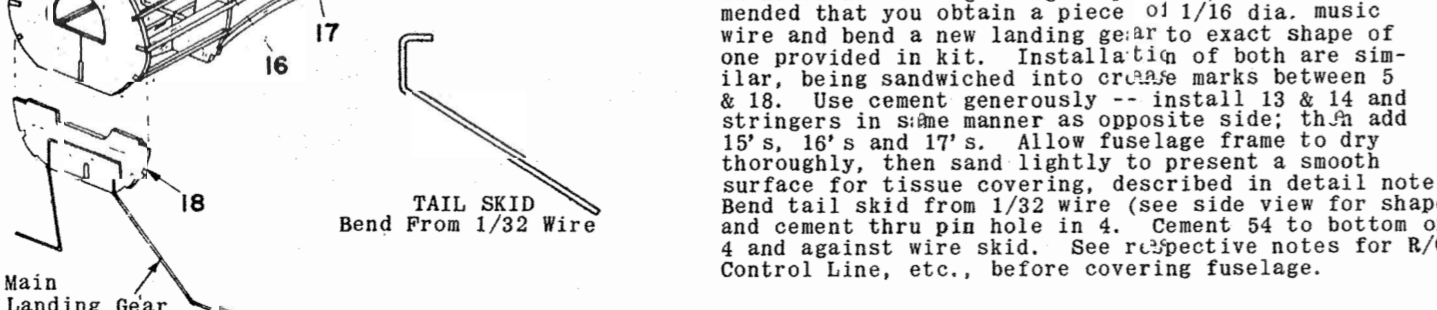
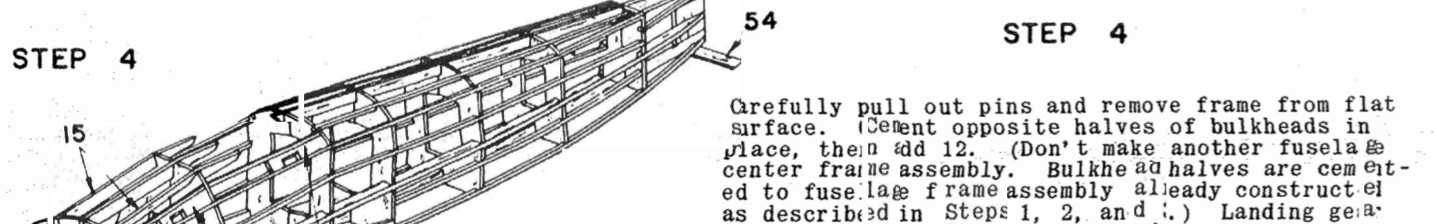
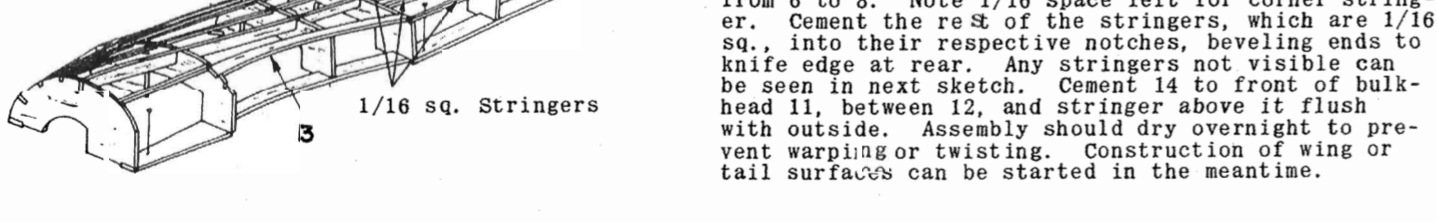

**RIB ANGLE DETAIL**  
Sketch above shows how wing rib angle template is used as described in Wing Step 2.

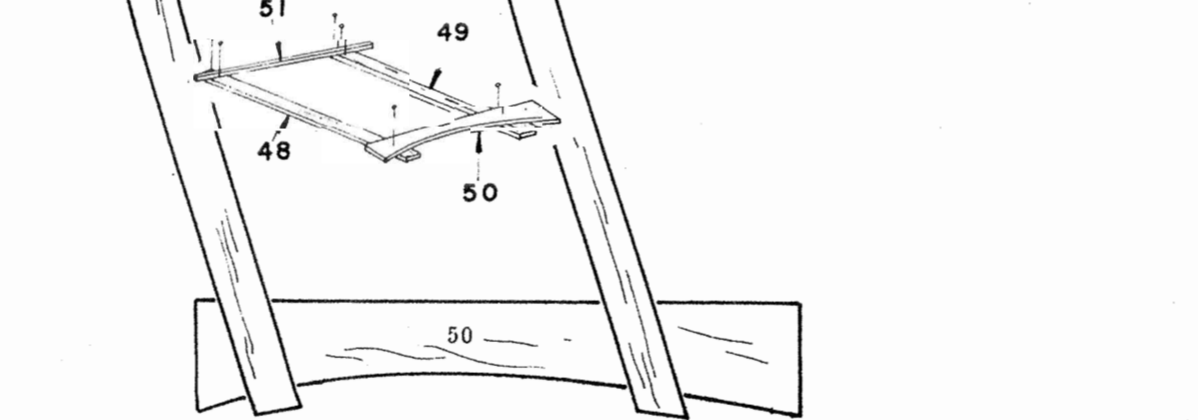

**STRUT DETAIL**  
Assemble two outer wing struts as shown above on full size drawing. Use cement lightly, since 50 & 51 are removed when wings are in place. Install as described in final assembly detail.

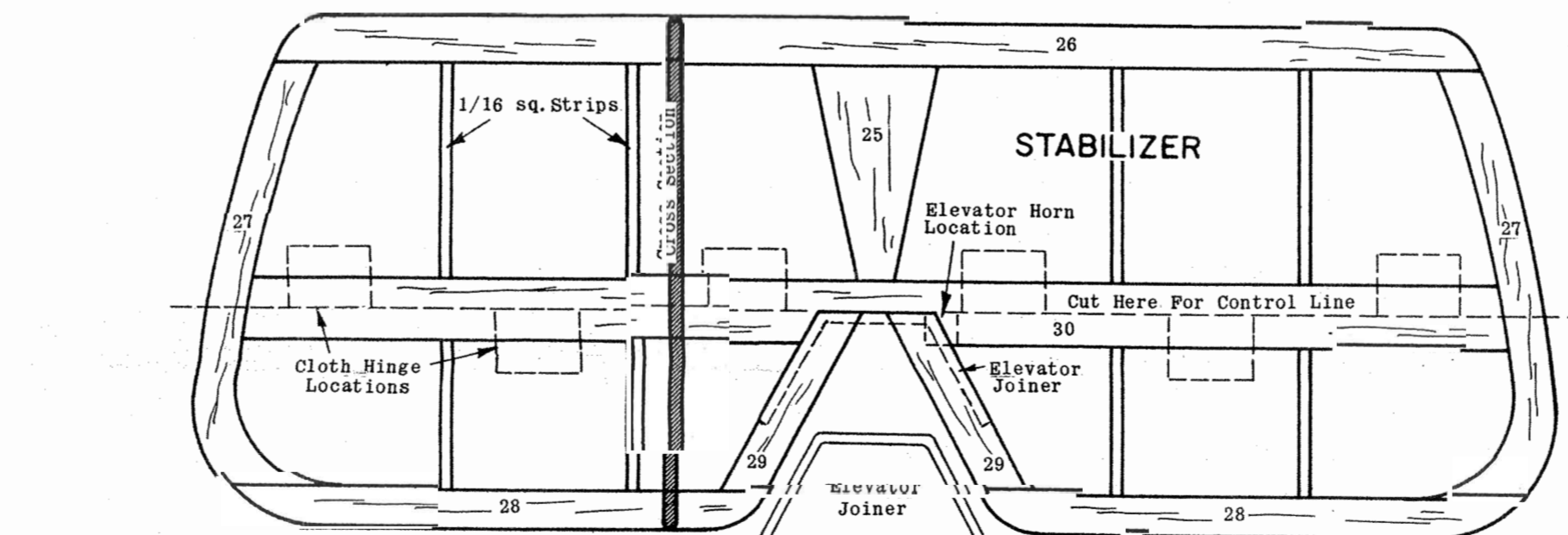

**TAIL SURFACE ASSEMBLY**

Assemble stabilizer by pinning parts 25 to 30 to plan on flat surface as shown, cementing them to each other where they join. Cut 1/16 sq. strips to fit & cement in place. Rudder is built in same manner, pinning parts 19 to 24 to plan & cementing to each other, then adding 1/16 sq. strips. Allow assemblies to dry thoroughly on flat surface, then sand smooth, rounding edges (except front of 19 and bottom of 20) as shown on cross-section. If model is being constructed for control line or radio, see respective detail notes BEFORE covering with tissue.

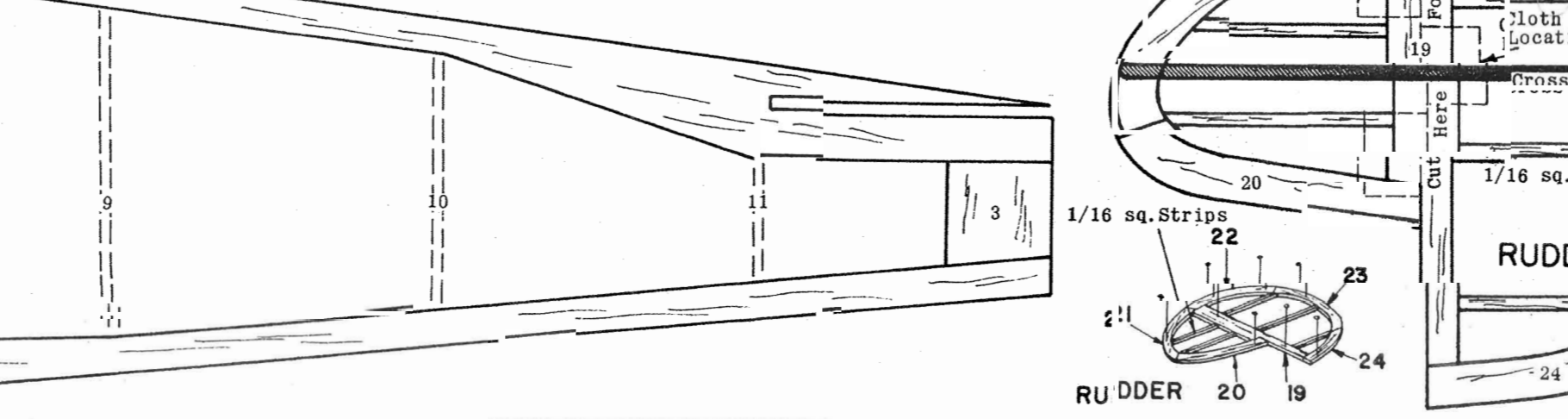

**TOP WING ASSEMBLY**

**STEP 1**  
Using 1/8 x 3/16 x 12 strips, cut leading edges and spars to proper length and pin in place on plan in upright position. All numbered parts are now pinned & cemented in place as shown. Do not cement center of leading edge & 31's where they join.

**STEP 2**  
Ribs 35's to 39's are now cemented in place. All ribs are vertical, except 35's which are cemented in place at angle as shown. Using rib angle template (see detail note). This provides for dihedral angle shown and described in next step. Cement 1/16 sq. spars into notches along top of ribs. Bevel ends of 1/16 sq. to fit at tip as shown. Allow frame to dry thoroughly before removing from flat surface, overnight recommended.

**STEP 3**  
Pull out pins carefully and remove frame from flat surface. Separate sections and trim and sand leading edge to shape shown on wing cross-section. Round off tips and trailing edge as shown, to blend smoothly into each other. Trim off leading edge, spars & trailing edge flush to angle of ribs 35, then cement sections together on flat surface, blocking up one side 2 1/2" at tip as shown. Measurement must be the same at leading and trailing edge so that the wing is not warped. Opposite section should be pinned or weighted to keep flat on surface. Use cement generously. Cement center spars 46 & 47 into notches across ribs as shown. Allow to dry thoroughly (overnite recommended). Then dry, sand frame smooth to prepare for tissue covering.

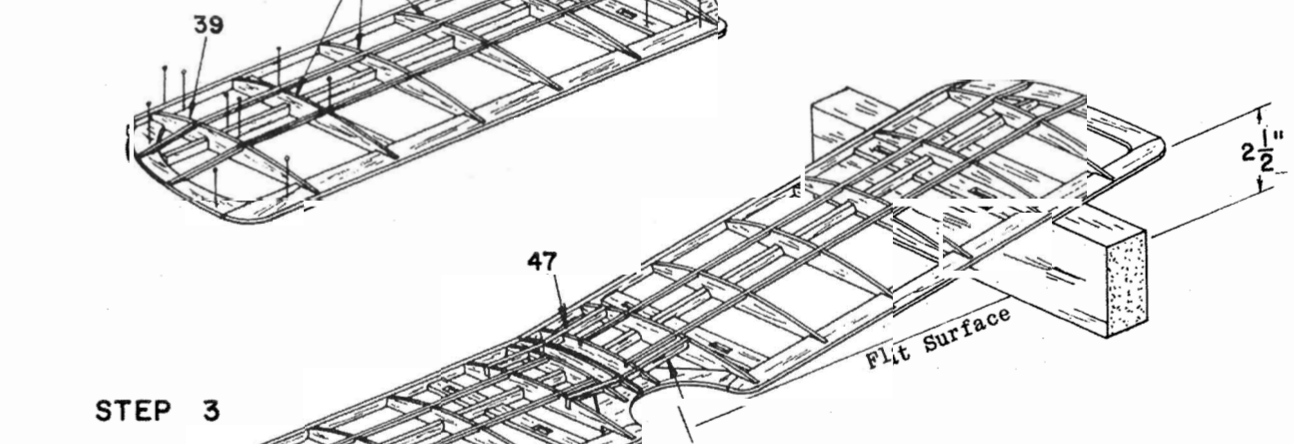
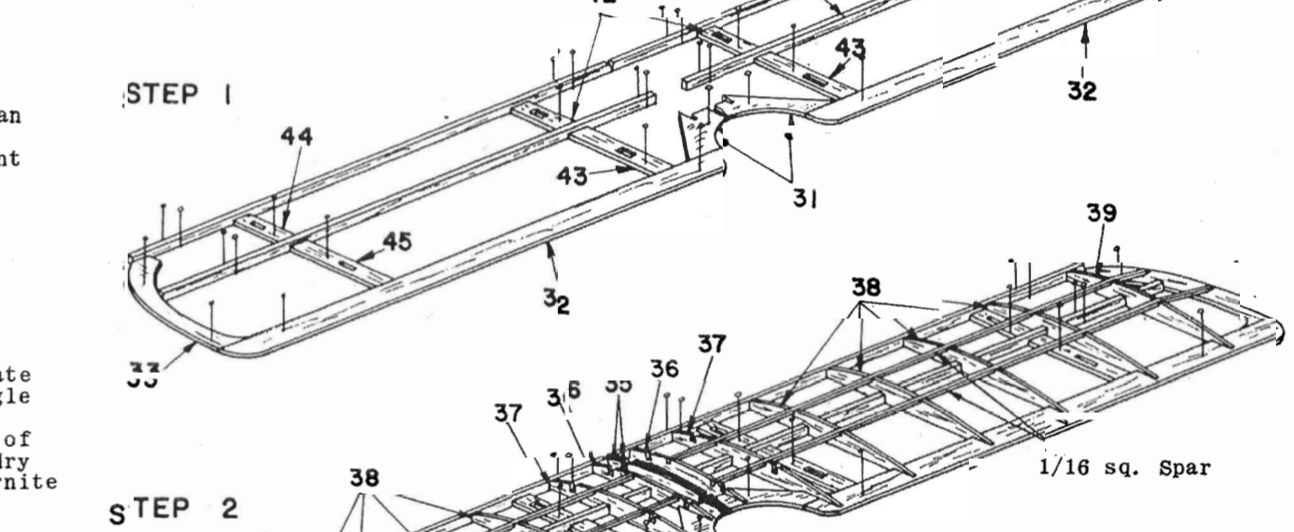
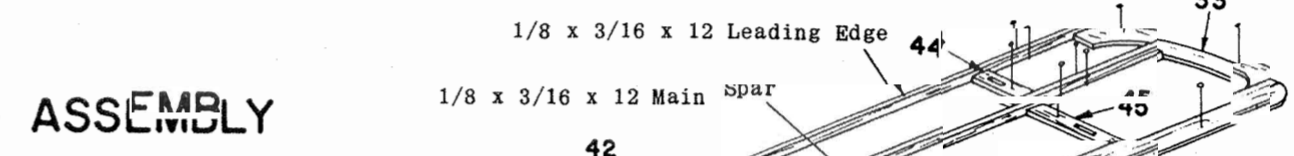

**BOTTOM WING ASSEMBLY**

Construction, shown in 3 steps, is similar to top wing, except that the strut gussets 40 & 41 are cemented flush with top of ribs. Install dihedral in same manner.

