

INSTRUCTION AND WARNING SHEET

HOW TO USE PROPELLER SAFELY & PROPERLY

The failure to read and follow instructions, abuse of models, may result in serious personal injury or death.

- For correct propeller size and pitch, follow the instructions on the propeller box. Do not use a propeller that is not the correct size or pitch.
- Install prop with correct rotation. See the correct rotation propeller on the correct wrench for this purpose.
- When starting engine, propellers may (20 feet or more) fly off the propeller. If flying propeller, use caution. Do not look directly at the propeller. Do not look directly at the propeller. Do not look directly at the propeller.
- Keep hands away from prop as much as possible. Use "fingerless" gloves or other protective devices. Do not use bare hands. Do not use bare hands.
- Keep face and body away from path of prop as you start and run engine.
- Make all engine adjustments from behind rotating prop.
- To shut engine, cut off fuel supply or follow engine manufacturer's directions. DO NOT use hands, fingers or any part of body. DO NOT throw anything into a running engine.
- Observe any areas with holes, protrusions, splits or cracks or any sign of wear or damage. Never repair, alter, make or bend a prop. Normal engine vibration can loosen a prop. Inspect and replace if necessary.

ADDITIONAL PRECAUTIONS

- Use safety glasses when starting or running engine.
- Do not repair in area of loose ground or sand. Prop may throw back material in face or eye.
- KEEP AWAY FROM PROP. Loose clothing — shirt sleeves — ties — cuffs or loose objects (pens, screw drivers) that may fall out of hand or pocket may hit prop.
- Make certain prop clip or connector is secure so that it will not slip off or otherwise get into running prop.
- If a splitter is used, be certain its edges do not touch the prop.

ADDITIONAL SPECIAL WARNINGS AND INSTRUCTIONS FOR WIND PROPELLERS

When prop is attached to amount of wind in the air and will become brittle and break if too dry. Store amount of moisture and gravity from time of manufacture, do as follows:

- Soak with prop. Do not soak for 30 minutes.
- When dry use. Make certain cover the entire prop. Do not cover just. Let prop stay in water until dry.
- You can add the oil, etc. in the water to identify broken prop. Do not reuse.
- After use of prop, remove from engine, wrap in moist cloth, paper towel, or rag, and store in a water tight plastic bag.

TOP FLITE MODELS, INC.
Chicago, Ill. 60628

WARNING:

A Radio Controlled Model is not a "toy". Care and caution must be taken in properly building the model as well as in the construction and use of the Radio Control device. It is important to follow all directions in construction of this kit as well as installation and use of the engine and controls. The safety and accuracy of a well experienced builder and pilot is highly recommended. Do not take chances. Inspect building, operation or flying of this model could result in serious bodily injury to others, yourself, or property damage.

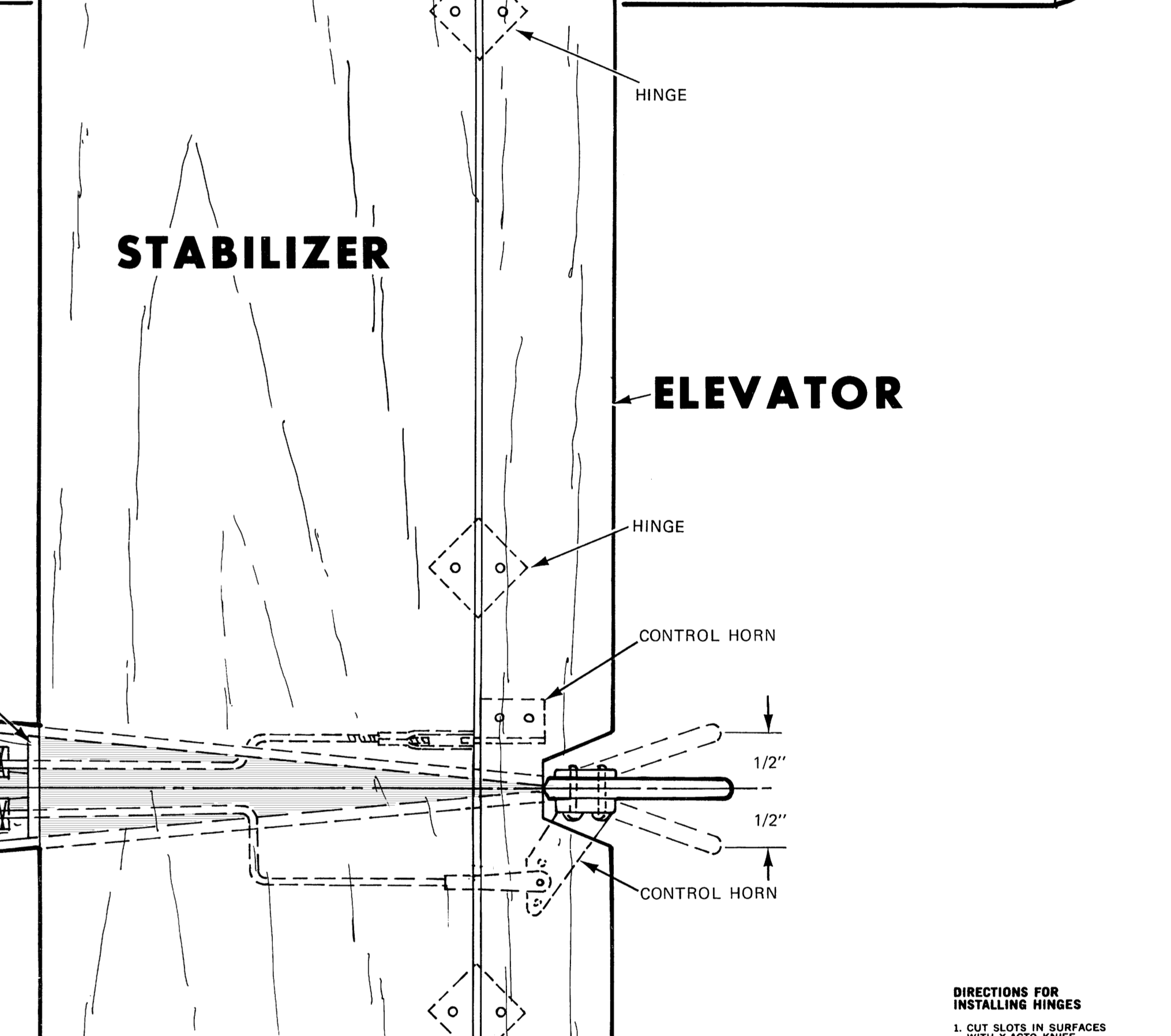

- DIRECTIONS FOR INSTALLING HINGES**
- CUT HOLES IN SURFACES WITH 3/32" BIT.
 - CREATE GROOVE BEFORE INSTALLING HINGE.
 - DRILL HOLES THRU SURFACES AND HINGES.
 - DO NOT TOUCH UP IN GLUE AND INSTALL.
 - CUT EXTERIOR PORTIONS OF HOLES WITH 3/32" BIT.

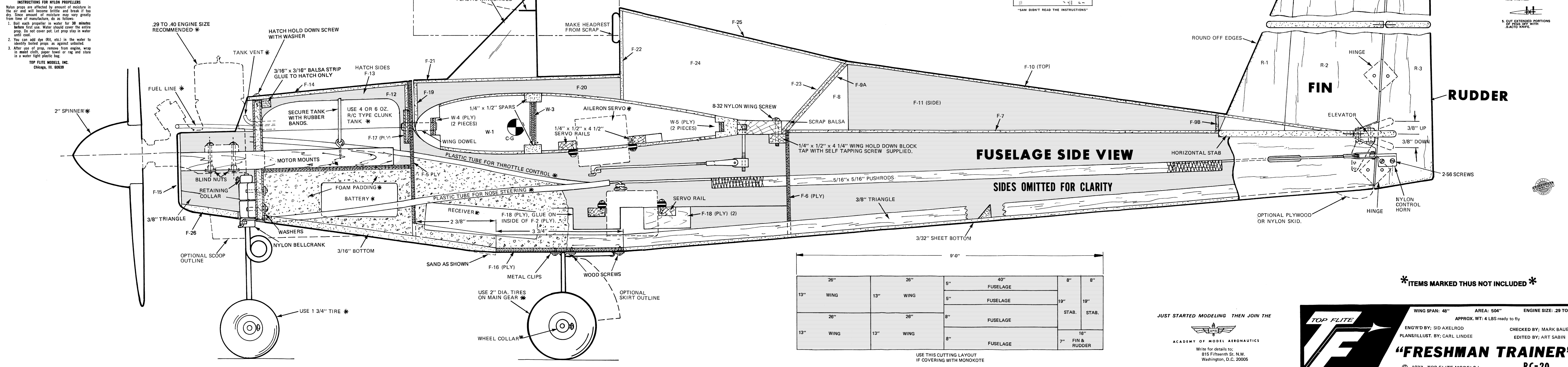
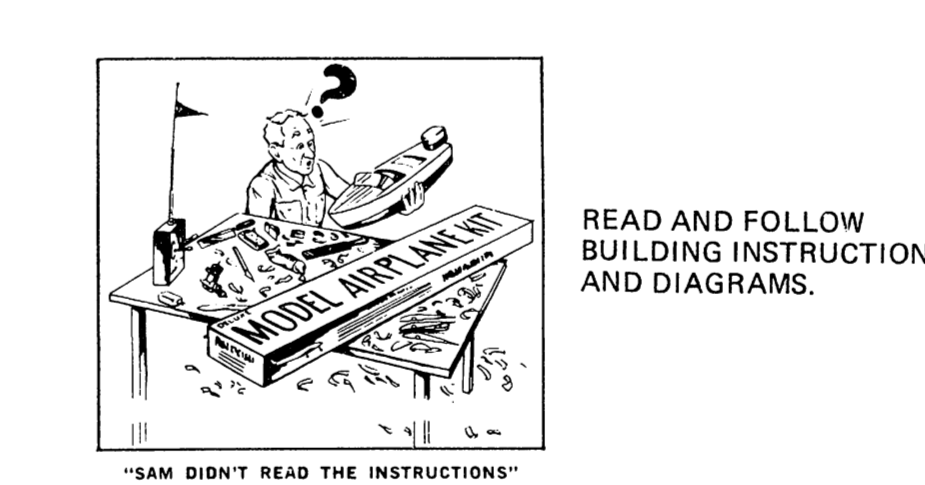

26"	26"	40"	8"	8"
13" WING	13" WING	FUSELAGE	STAR	STAR
30"	26"	FUSELAGE	7"	FIN & RUDDER
13" WING	13" WING	FUSELAGE		

USE THIS CUTTING LAYOUT IF COVERING WITH MONOKOTE

ITEMS MARKED THUS NOT INCLUDED

JUST STARTED MODELING THEN JOIN THE
ACADEMY OF MODEL AERONAUTICS
Write for details to:
BIS 17 Research St., N.W.
Washington, D.C. 20005

TOP FLITE

WING SPAN: 48" AREA: 604" ENGINE SIZE: 29 TO 40 APPROX. WT: 4 LBS ready to fly

ENGR'D BY: SID AXELROD PLANN'G ILLUSTR. BY: CARL LINDEE CHECKED BY: MARK BAUER EDITED BY: ART SABIN

"FRESHMAN TRAINER"

© 1977 TOP FLITE MODELS, INC. RC-20



RC-20 FRESHMAN

PRODUCT IMPROVEMENT BULLETIN

The INSTRUCTION BOOK REVISIONS show additional steps that have been added to improve the 'Freshman'.

INSTRUCTION BOOK REVISIONS

WING

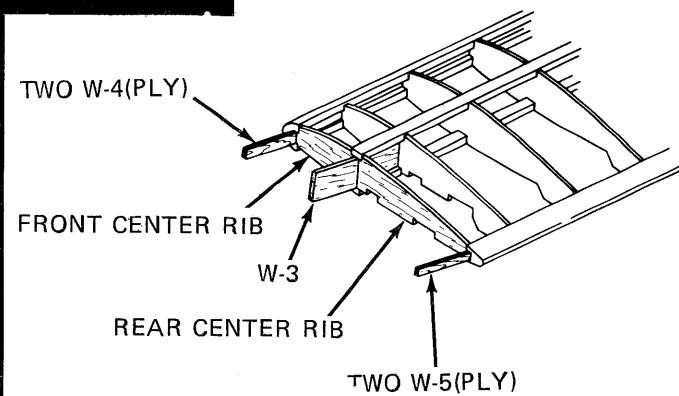

STEP 3

- Starting at check box 3 in the instruction book, Glue two W-4(PLY) and two W-5(PLY) to the leading and trailing edges as shown.
- Glue in W-3 balsa dihedral brace. Glue in the front center rib. Use the dihedral guide to obtain the correct rib angle.
- Glue the rear center rib in place, again using the dihedral guide for the correct rib angle.

WING

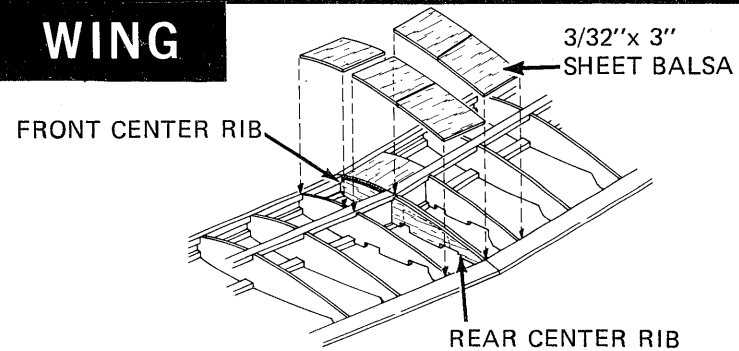

STEP 4

- Disregard instructions in step 4 of instruction book.
- Block up the completed left wing 3-1/4" to 3-1/2" at tip. Lay in bottom spar and glue to W-3.
- Glue front and rear center ribs in place.
- Complete right wing assembly as per steps 1, 2 & 3
- Fit 3/32"x3" balsa sheet to top of wing center section and glue as shown.
- Allow to dry, and then turn wing over.
- Continue with WING-STEP 5 in the instruction book.

FINAL ASSEMBLY

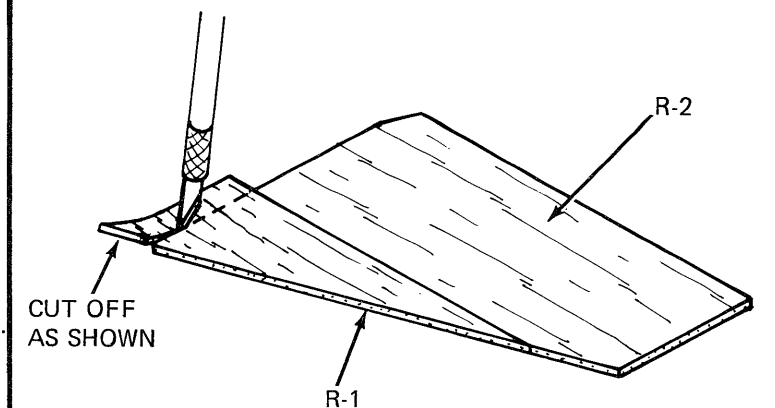

STEP 3

- Follow the 1st and 2nd check blocks of FINAL ASSEMBLY- STEP 3 in instruction book. Disregard the 3rd check block.
- R-1 will be longer than R-2. Using a sharp knife, cut off the bottom of R-1 even with R-2.
- Glue fin in place and pin. Make sure it is vertical.

PLAN REVISIONS

NOTES AND DIMENSIONS SHOWN BELOW INDICATE CHANGES OR ADDITIONS TO THE MAIN PLANS.

THESE NOTCHES SHOULD BE ON RIGHT SIDE FOR ENGINES WITH R.H. THROTTLE. LEFT SIDE FOR L.H. THROTTLE. CHECK ENGINE.

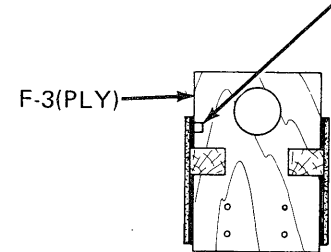
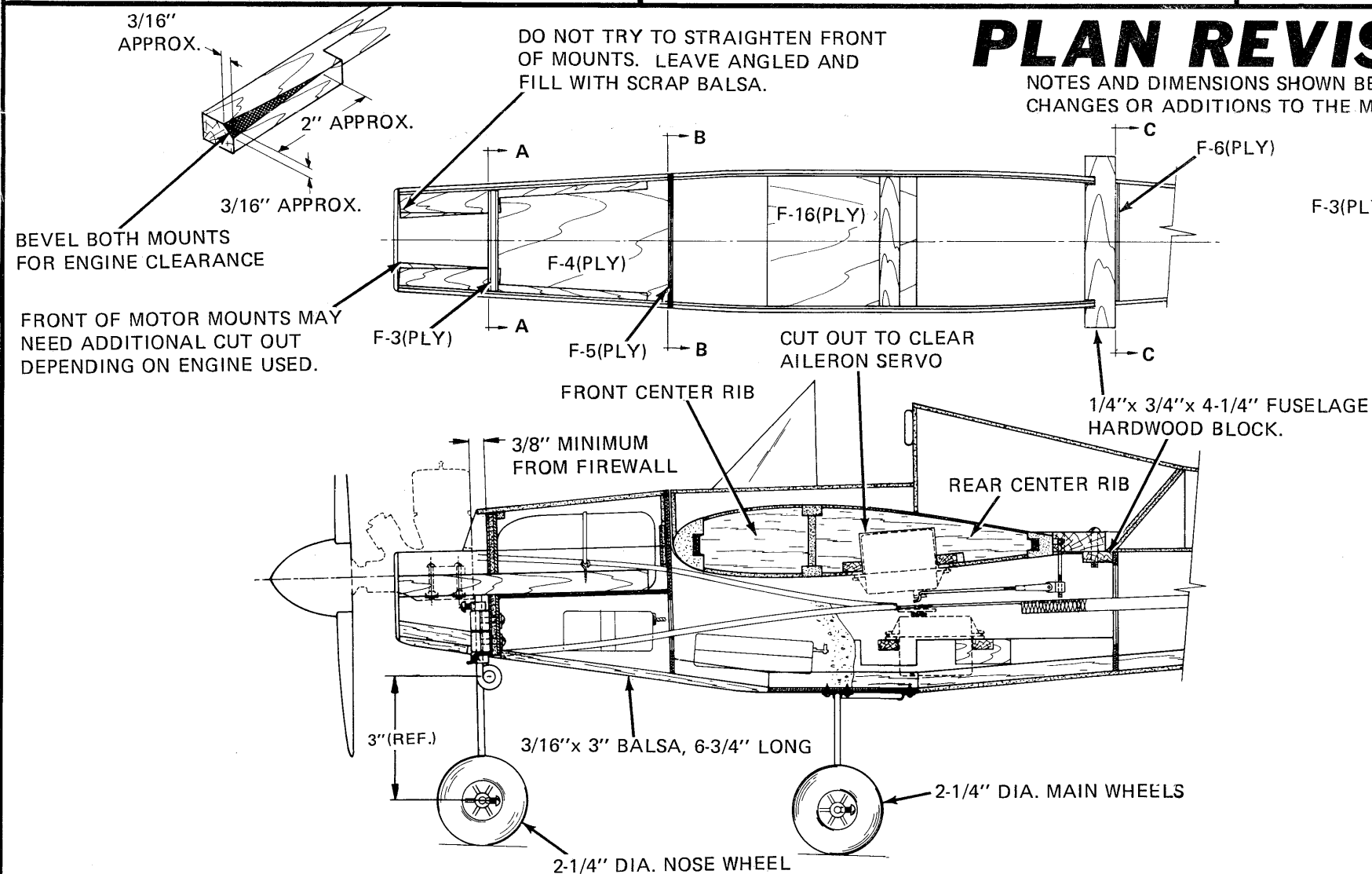

SECTION A-A

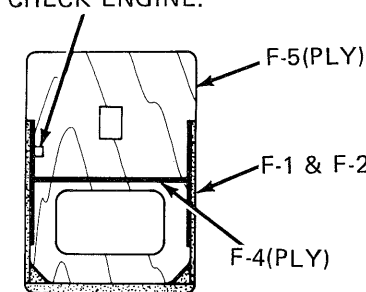

SECTION B-B

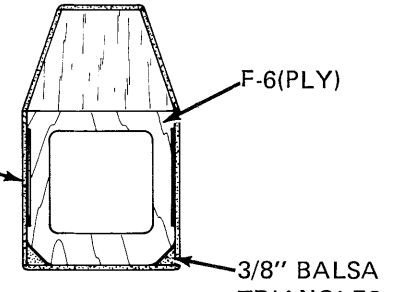

SECTION C-C

NOTE:

DURING CONSTRUCTION OF YOUR FRESHMAN TRAINER, KEEP CROSS CHECKING BETWEEN THIS BULLETIN, THE PLANS AND THE INSTRUCTION BOOK.

DURING EACH STEP, CHECK THIS SHEET. INFORMATION IN THIS BULLETIN SUPERCEDES THAT SHOWN ON THE PLANS OR IN THE INSTRUCTION BOOK.

