

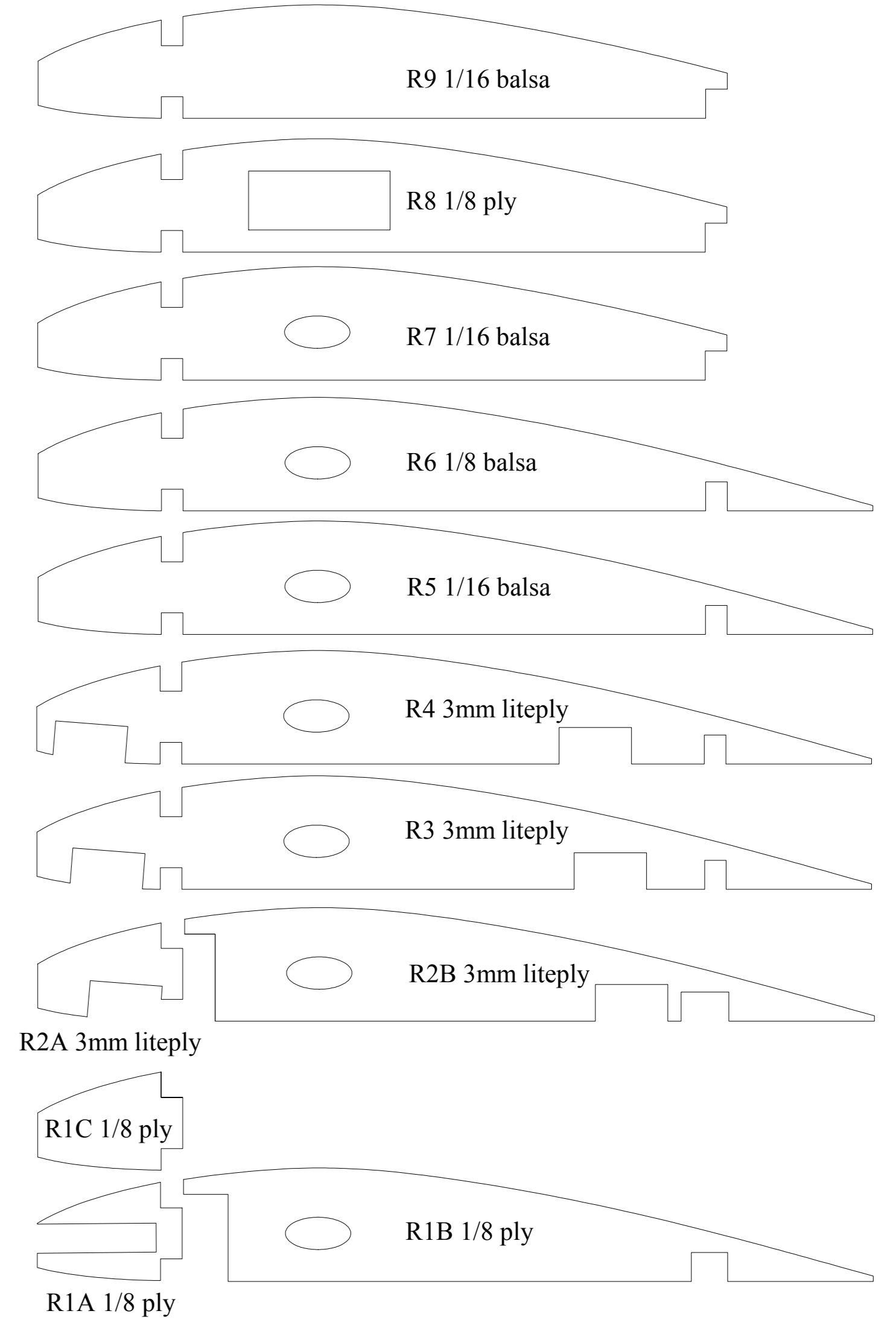

Peter Rake's  
**Ryan PT-22**  
 Copyright P. Rake 2012

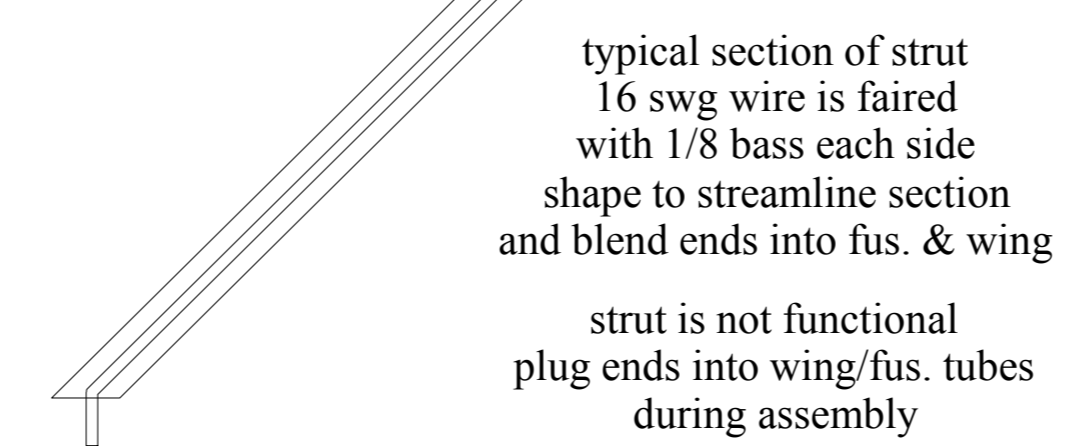

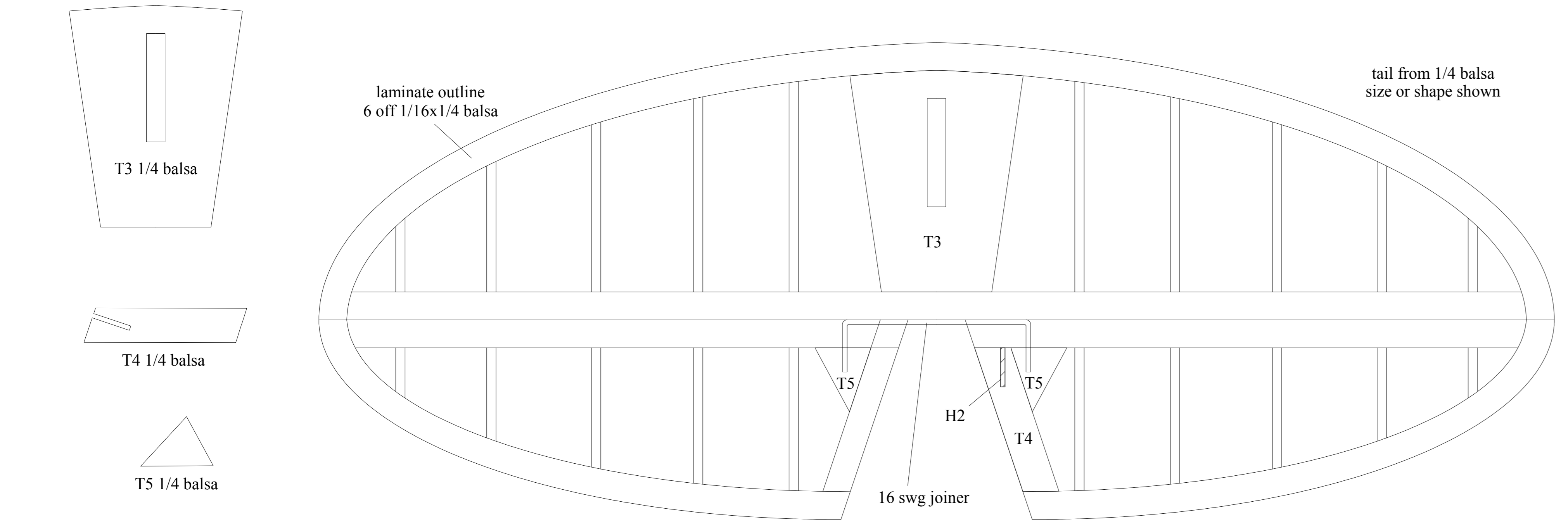
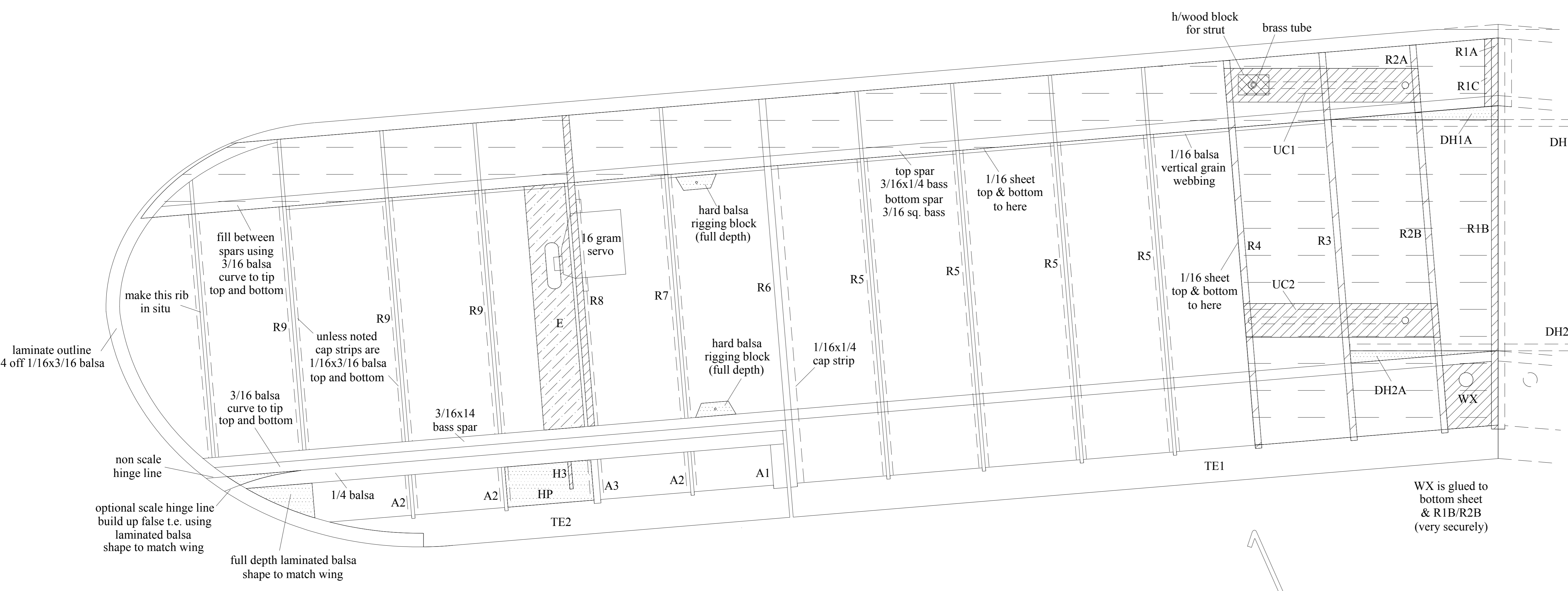
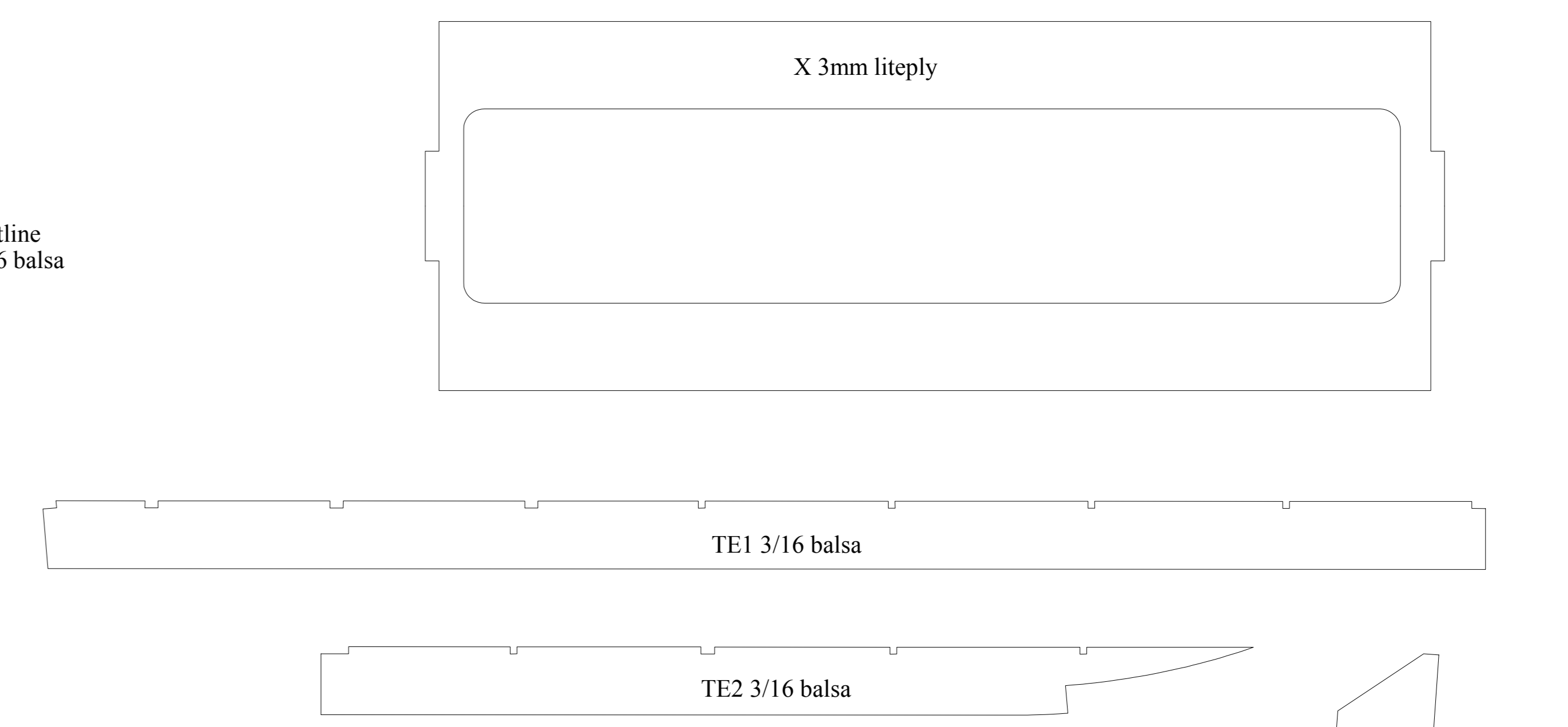
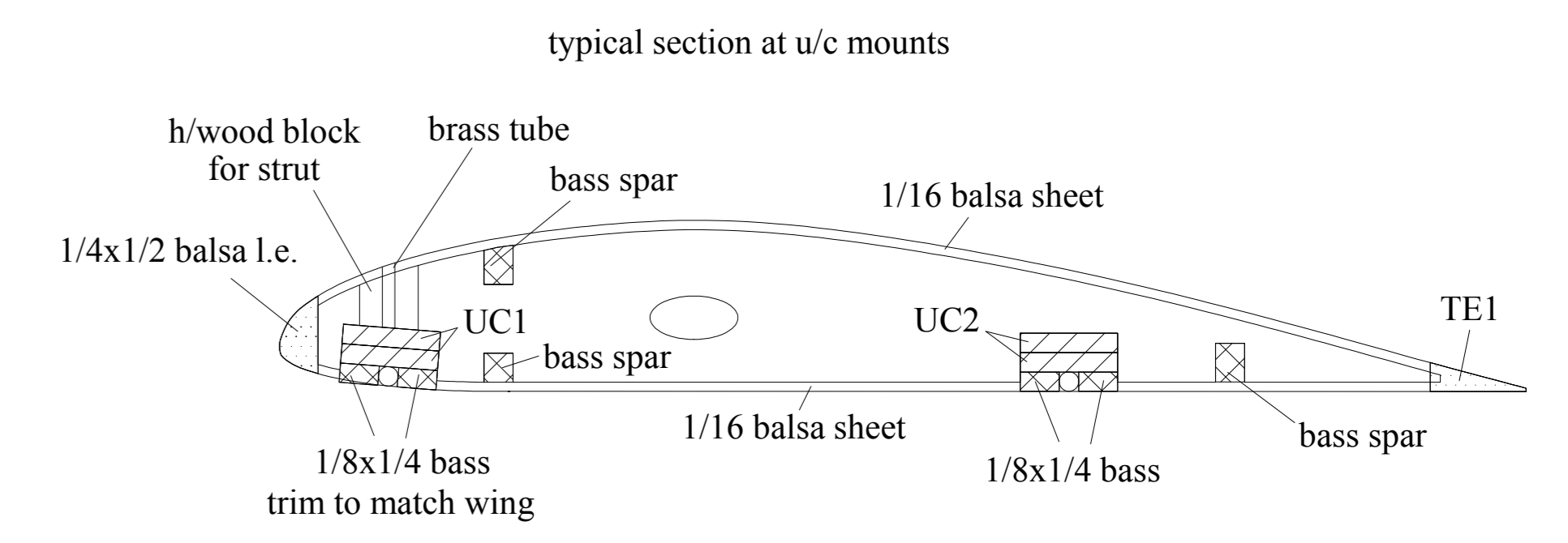
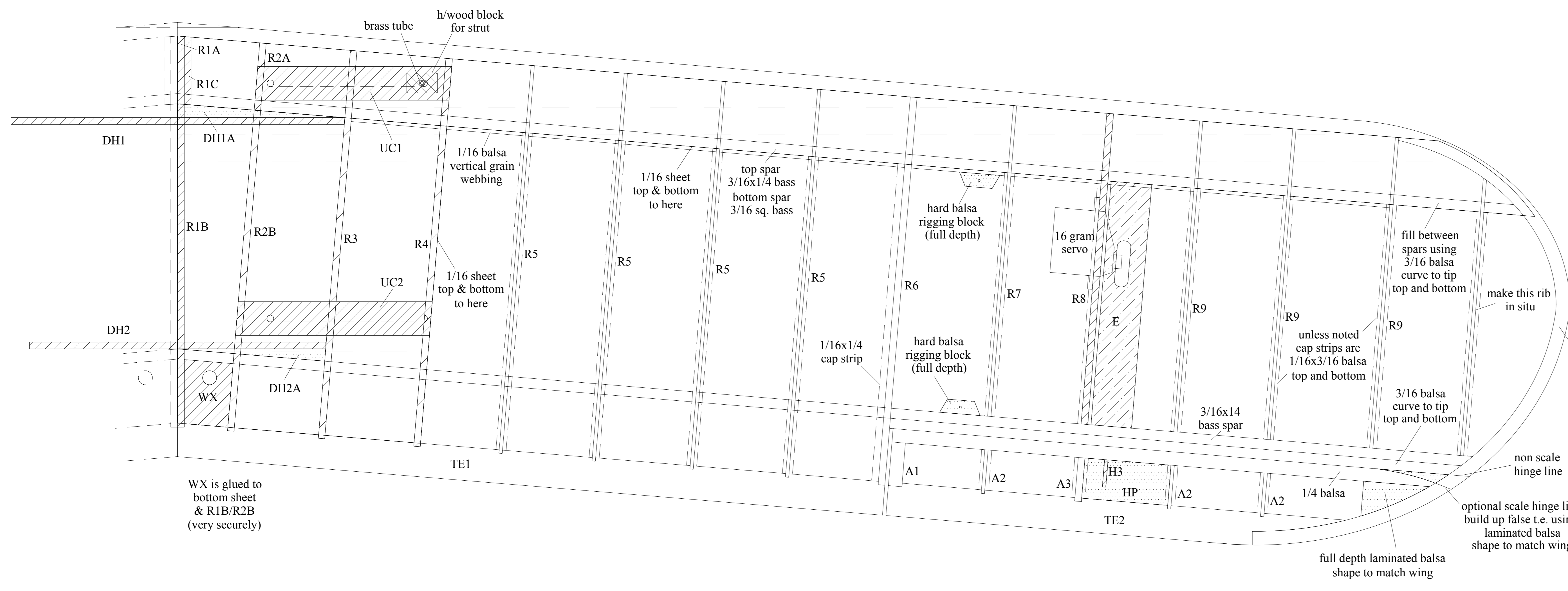
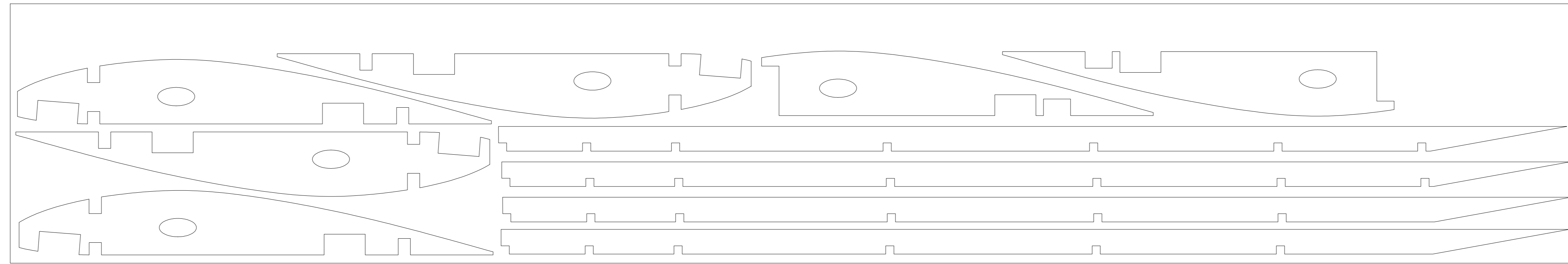

3mm liteply

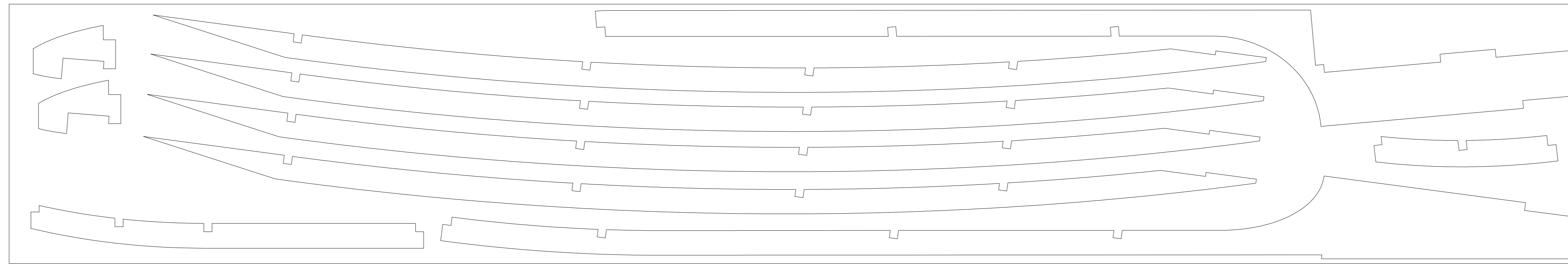

3mm liteply

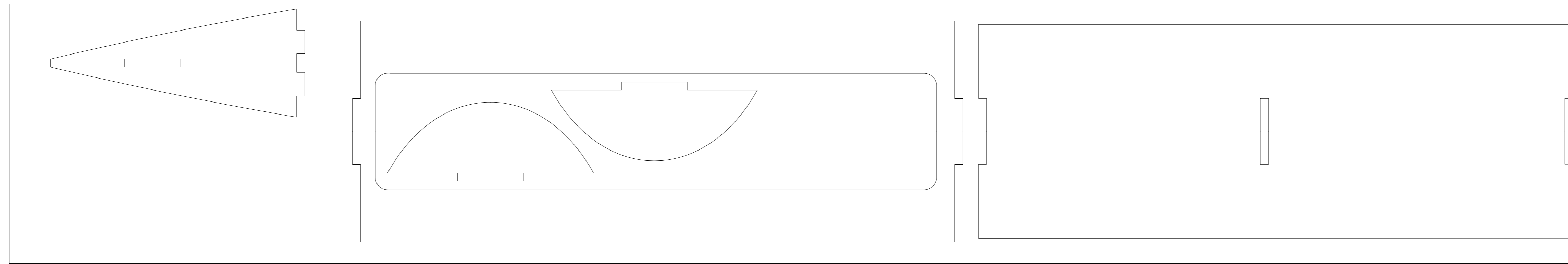

3mm liteply

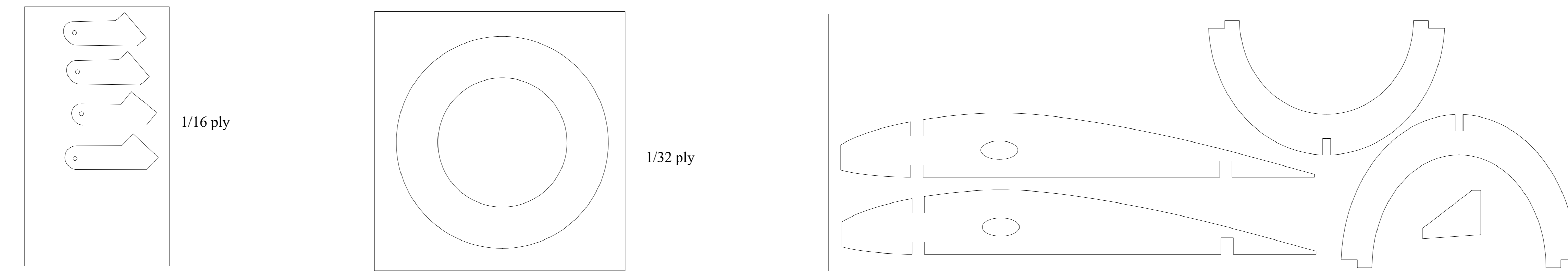

1/16 ply

1/32 ply

1/8 balsa

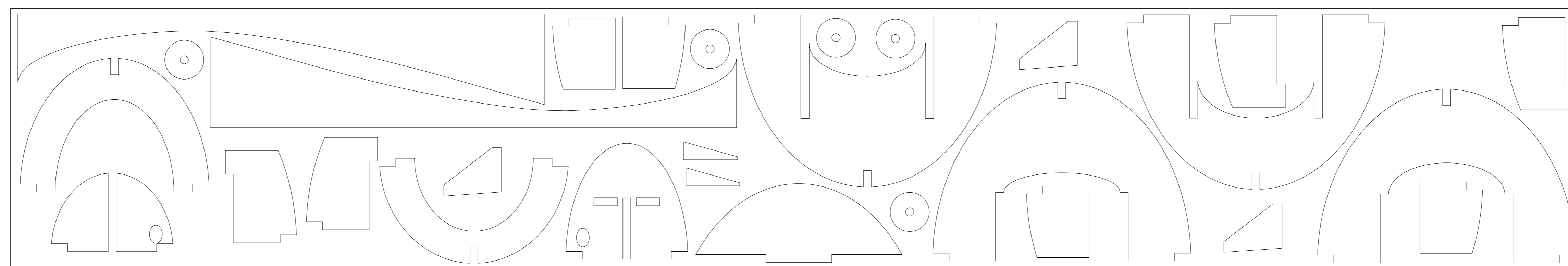

1/8 balsa

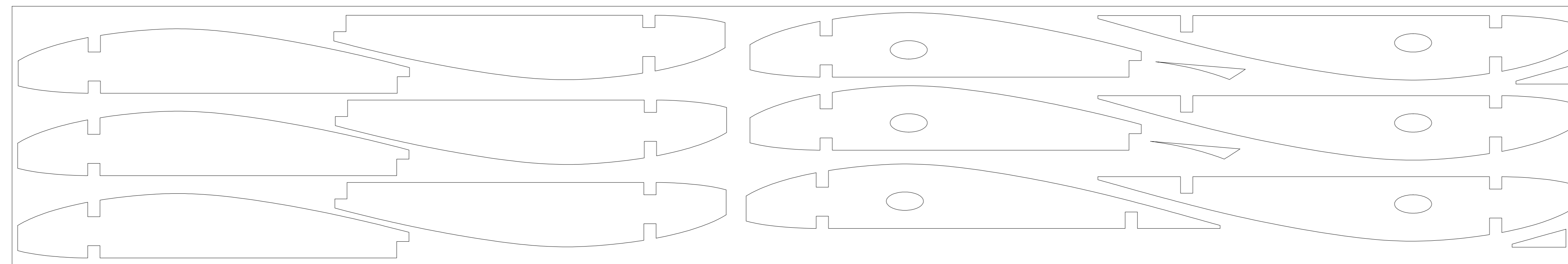

1/16 balsa

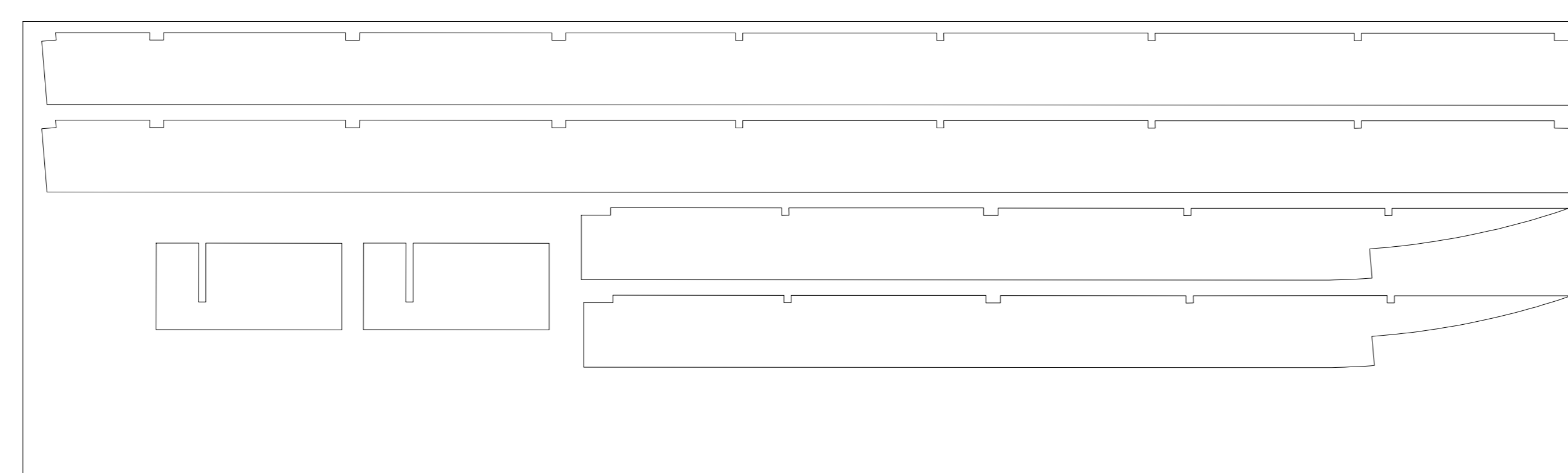

3/16 balsa

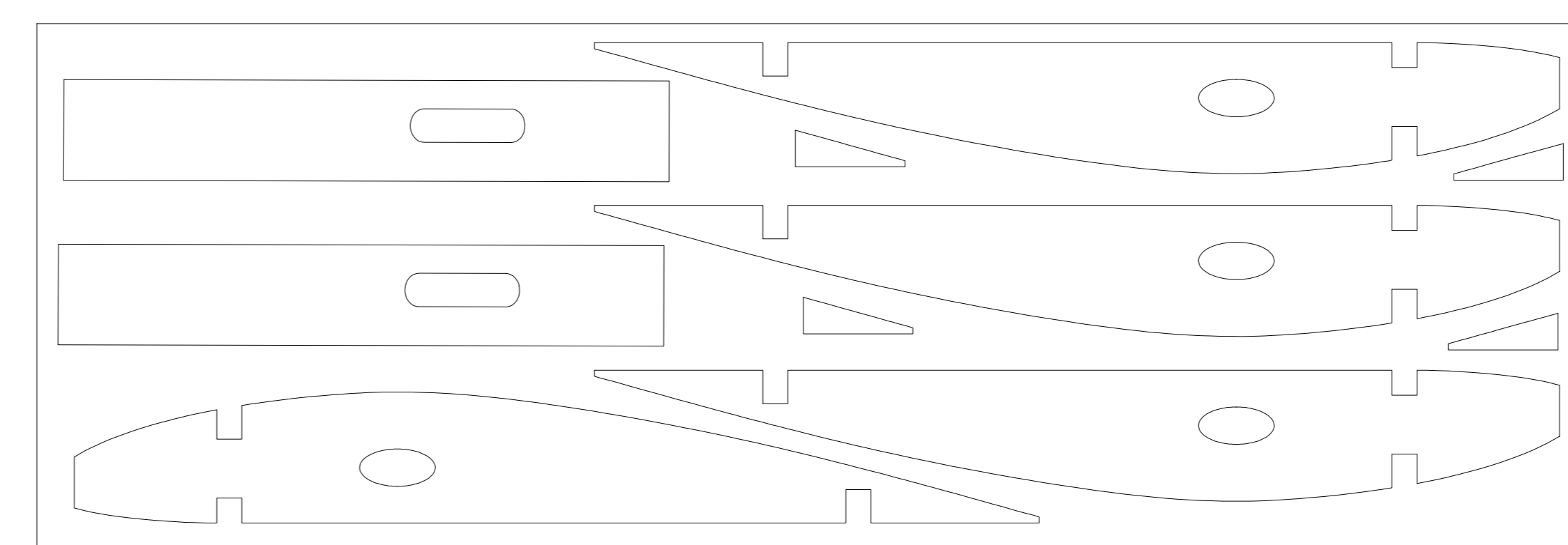

1/16 balsa

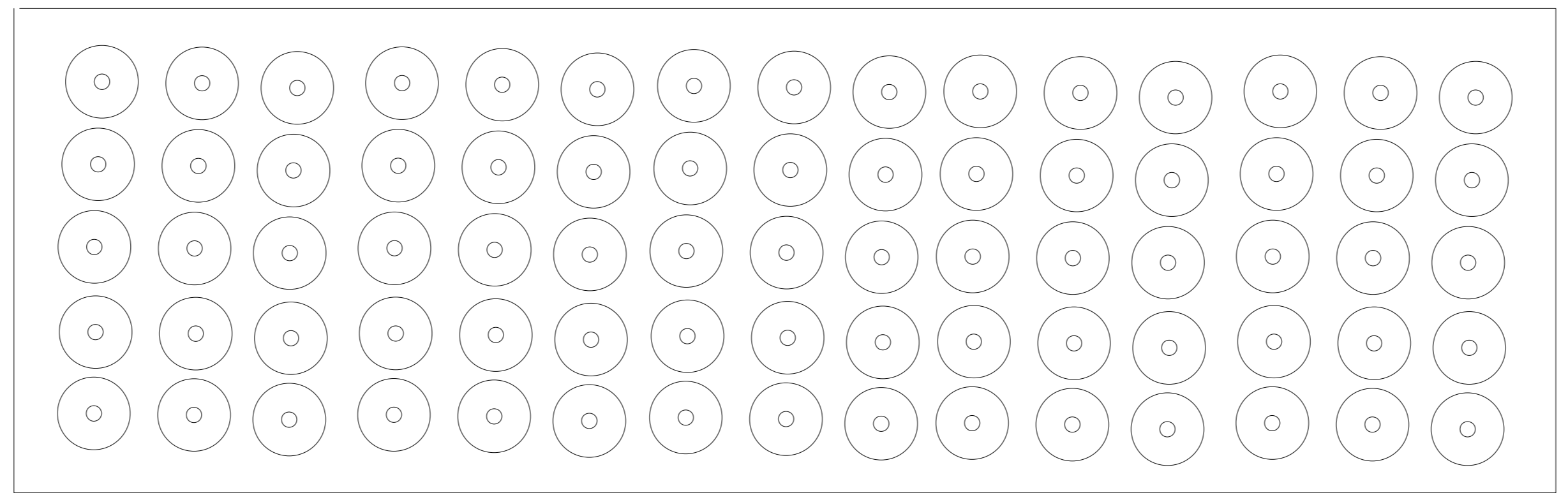

1 off 1/16 balsa

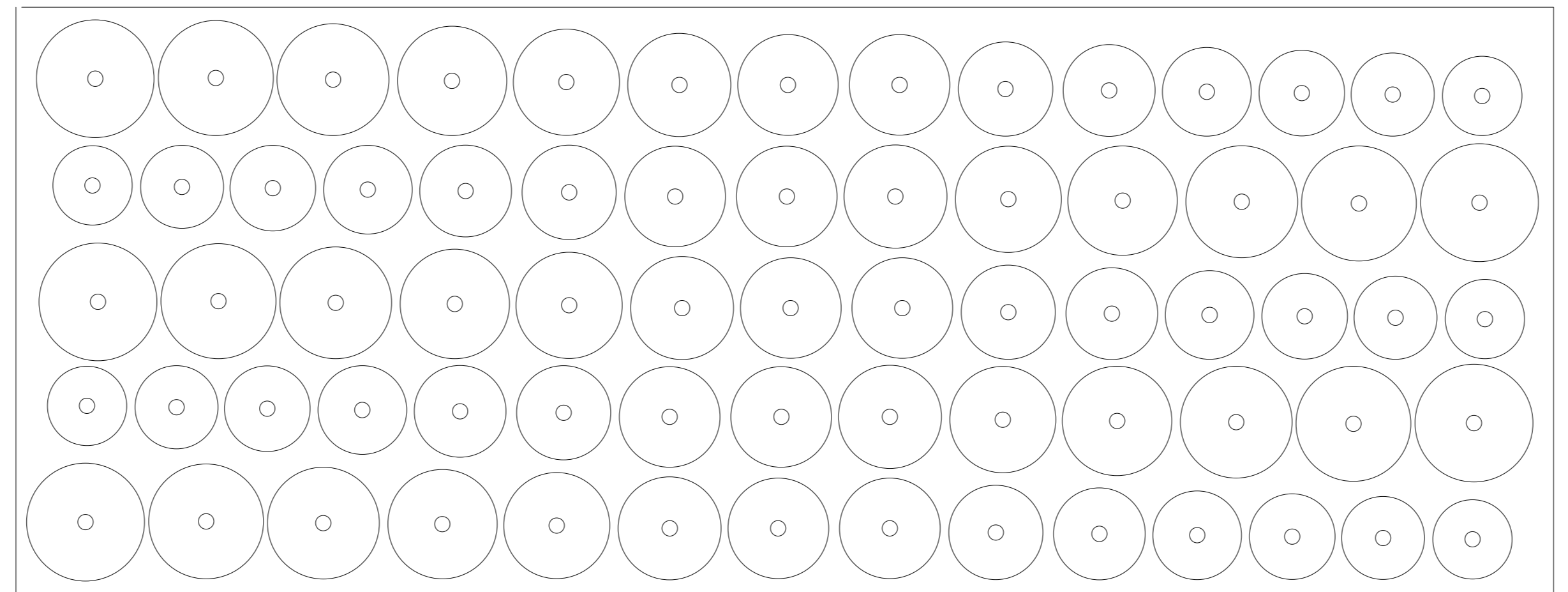

1 off 1/64 ply

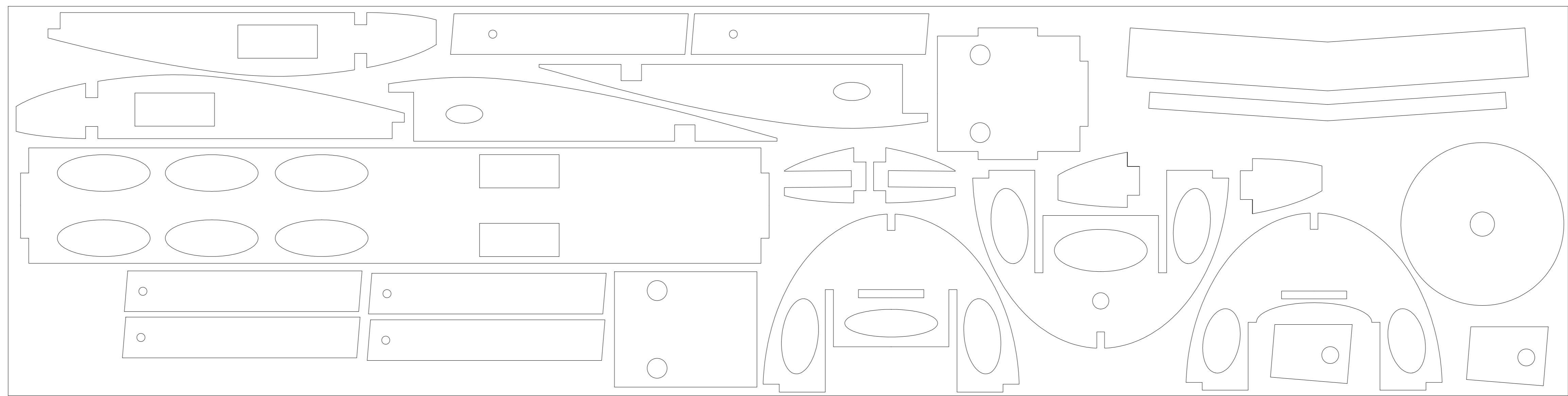

1/8 ply

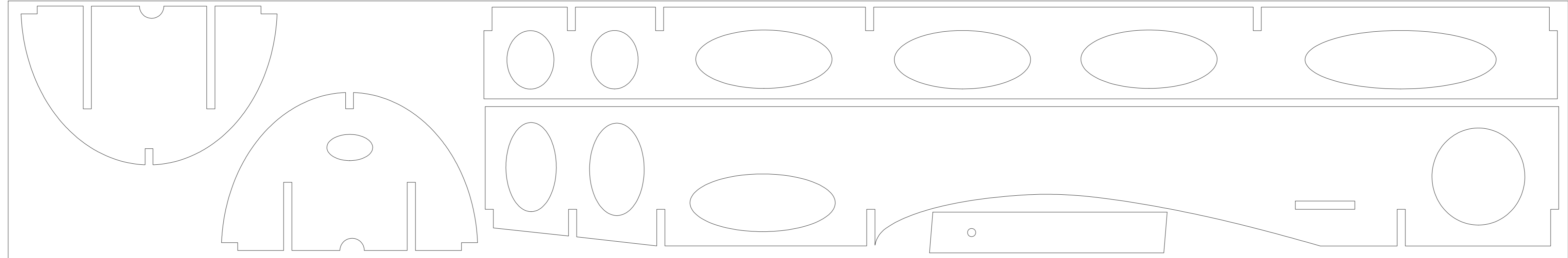

1/8 ply

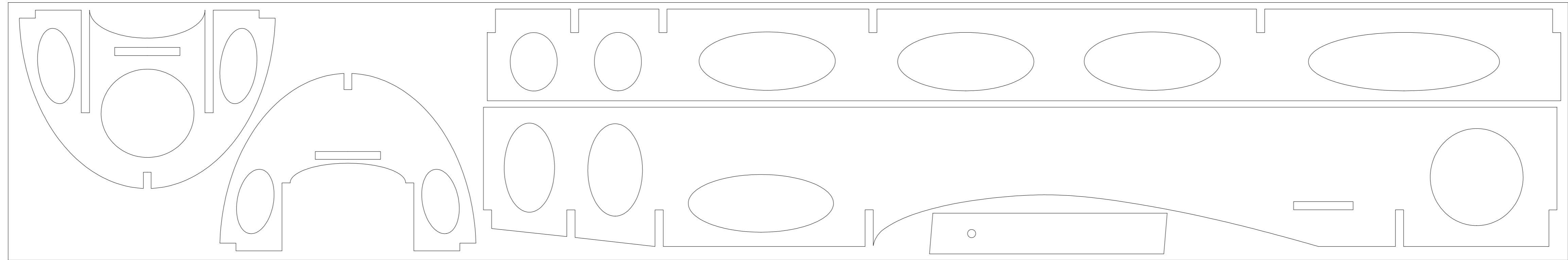

1/8 ply

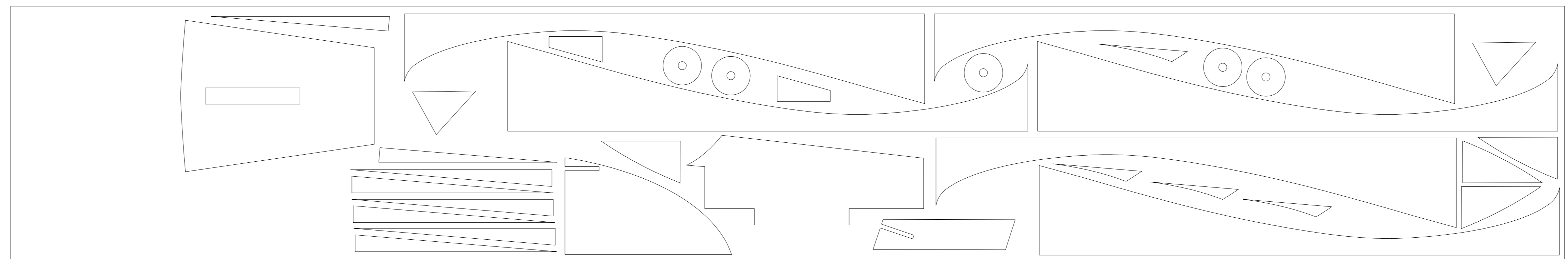

1/4 balsa