

PREVOIR TRINGLERIE GAZ... ET POSITION  
RESERVOIR SI MOTEUR INVERSE...



2 1/4" Spinner

CENTRE DE GRAVITE  
(30) du profil

renfort ctp 10/10

DOUBLAGE Balsa 20/10

MAXI PUNCH	Env 1451 mm Long 1410 mm Mot OS 46 SF ABC Radio 4 - 5 voies Masse 2.5 - 2.8 kg
17 / 11 / 1997	
TISON Franck	Planche 1 / 2



BLOC Balsa EN FORME SA EVIDER OU Balsa 60/10 + RAIDISSEURS

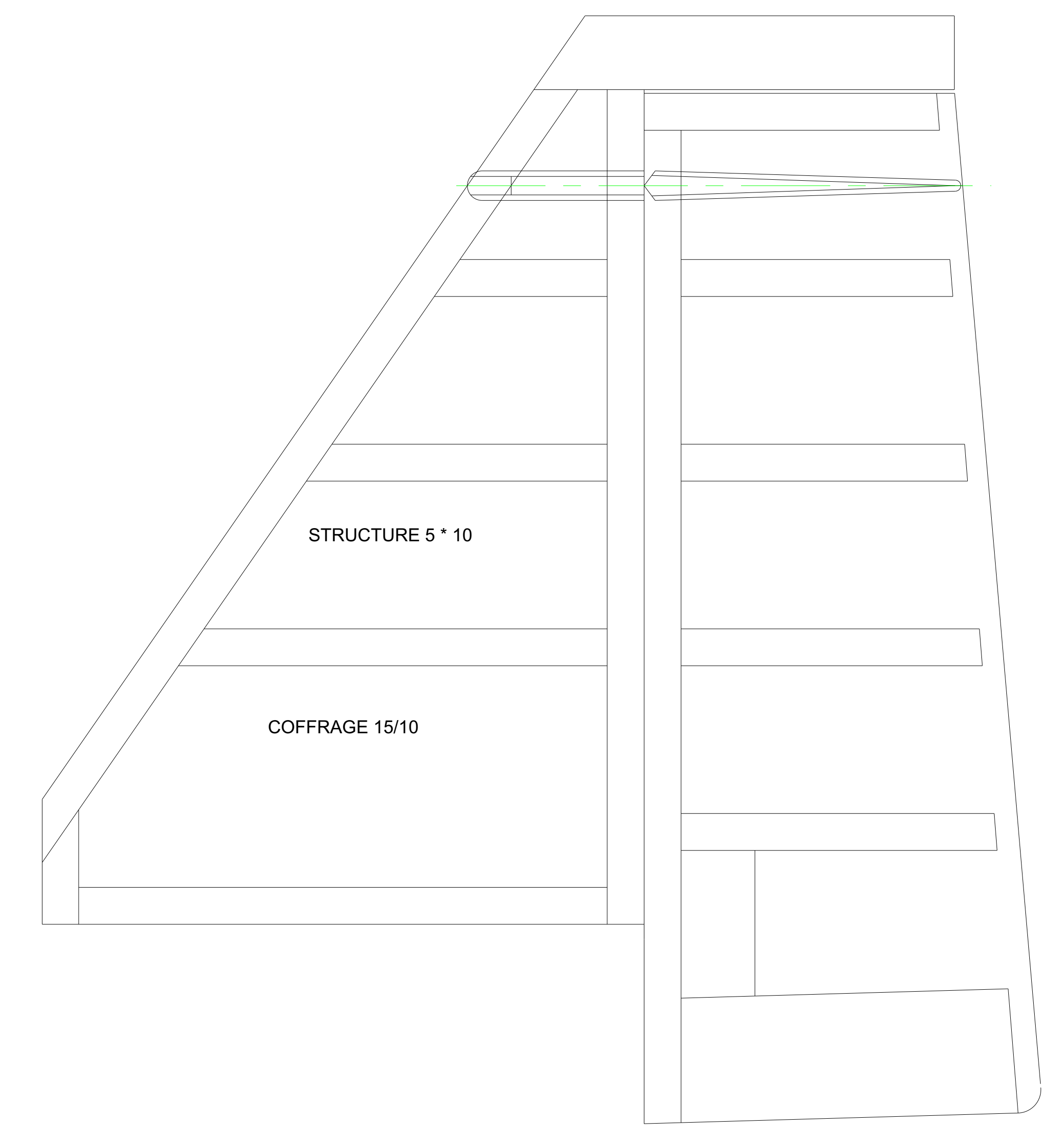
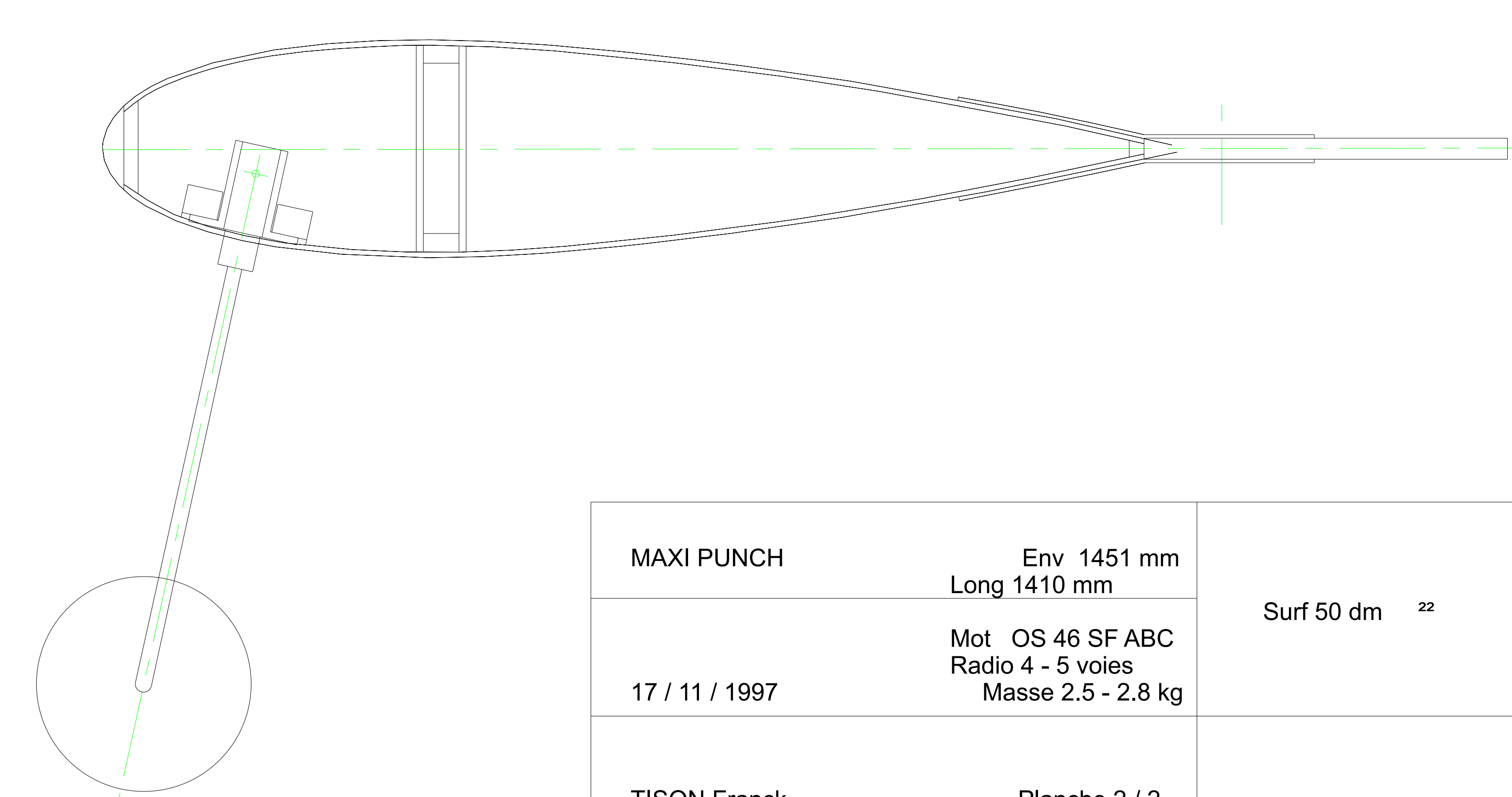
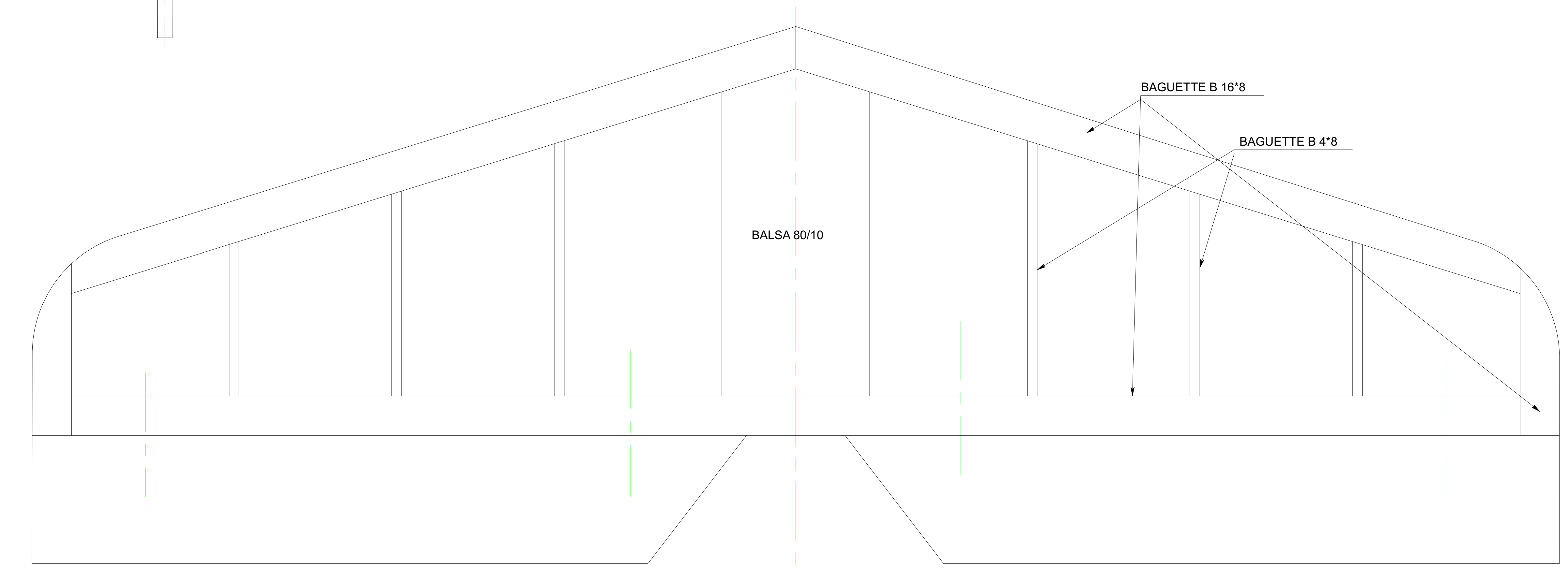

MAXI PUNCH	Env 1451 mm Long 1410 mm	Surf 50 dm <sup>22</sup>
17 / 11 / 1997	Mot OS 46 SF ABC Radio 4 - 5 voies Masse 2.5 - 2.8 kg	
TISON Franck	Planche 2 / 2	