

VERON

"GOBLIN"

20" SPAN SUPERLIGHT DURATION MODEL
FOR SIMPLE & EASY CONSTRUCTION.

MANUFACTURED BY

MODEL AIRCRAFT (Bournemouth) LTD.
NORWOOD PLACE, BOURNEMOUTH.

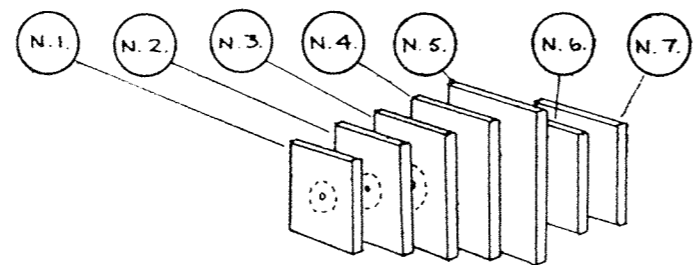

SKETCHES SHOWING FORMATION OF NOSEBLOCK FROM SMALL SQUARES OF 1/16" Balsa. LAMINATE TOGETHER, WHEN SET SAND & ADD ALUMINIUM NOSE FERRULE. LOCATE 20 S.W.G. SHAFT & CUPWASHER. BEND WIRE AS SHOWN & CEMENT INTO FACE OF PROPELLOR. CHECK FIT INTO FUSELAGE NOSE.

FIN TOP & TRAILING EDGE IS 1/16" x 1/4". TRIM TO OUTLINE.

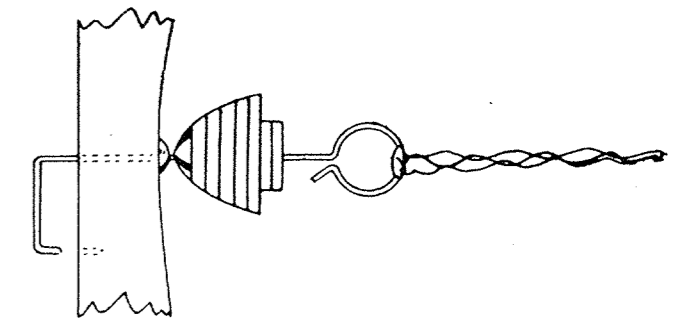

CHECK THAT SHAFT DOES NOT BIND IN NOSE FERRULE & THAT PROPELLOR RUNS TRUE.

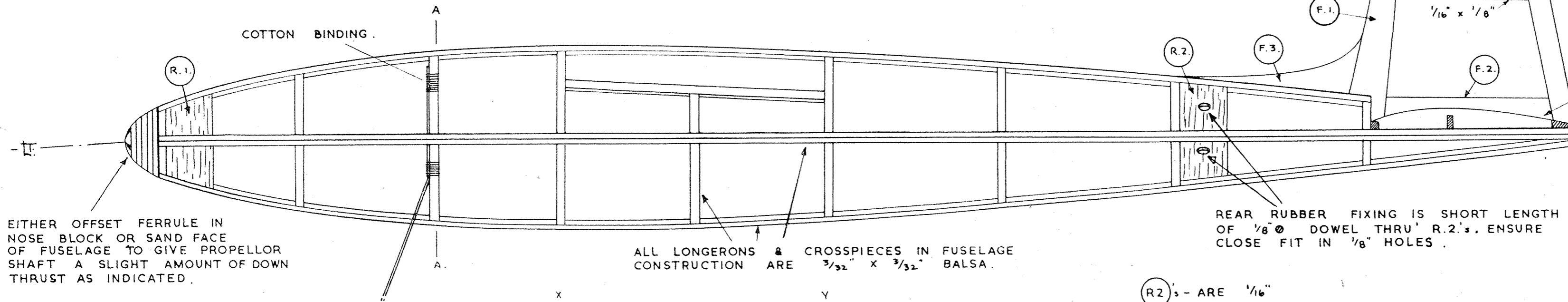

EITHER OFFSET FERRULE IN NOSE BLOCK OR SAND FACE OF FUSELAGE TO GIVE PROPELLOR SHAFT A SLIGHT AMOUNT OF DOWN THRUST AS INDICATED.

ALL LONGERONS & CROSSPIECES IN FUSELAGE CONSTRUCTION ARE 3/32" x 3/32" Balsa.

REAR RUBBER FIXING IS SHORT LENGTH OF 1/8" Ø DOWEL THRU R.2's. ENSURE CLOSE FIT IN 1/8" HOLES.

WHEN TAILPLANE HAS BEEN COVERED & DOPE, CEMENT TO STERN BAY. COVER FIN, DOPE & SIMILARLY CEMENT TO CENTRE RIB OF TAIL.

COTTON BINDING & CEMENT.

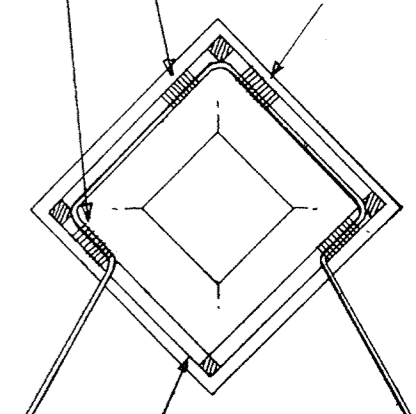

FORMER SHOWN IS AT A-A. OUTER LINE SHOWS F/U MAXIMUM WIDTH.

ACTUAL SHAPE & TRUE SIZE OF 20 S.W.G. U/C WIRE BENT AS SHOWN ABOVE TO FIT FUSELAGE CROSS SECTION AT A-A. BIND WITH COTTON TO CROSSPIECES.

TRACK FROM WHEEL CENTRES IS 5 1/2".

TRIM & SAND TIPS TO OUTLINE

1" DIAMETER WHEELS. RETAIN WITH SOLDERED OR CEMENTED WASHERS OR TIGHT BOUND FUSEWIRE.

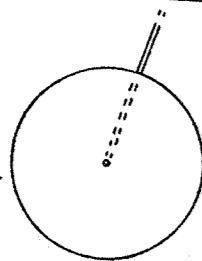

MAKE FIRST SIDE WITH VERTICAL BRACE & SECOND SIDE WITH HORIZONTAL WING SUPPORT.

SKETCH SHOWING SIMILAR CONSTRUCTION OF WING & STABILIZER TIPS. SPARS ARE TAPERED TO 1/16" x 1/16" AT TIPS FROM LAST RIB. 1/16" CORNER GUSSETS ARE ADDED & TRIMMED TO SHAPE.

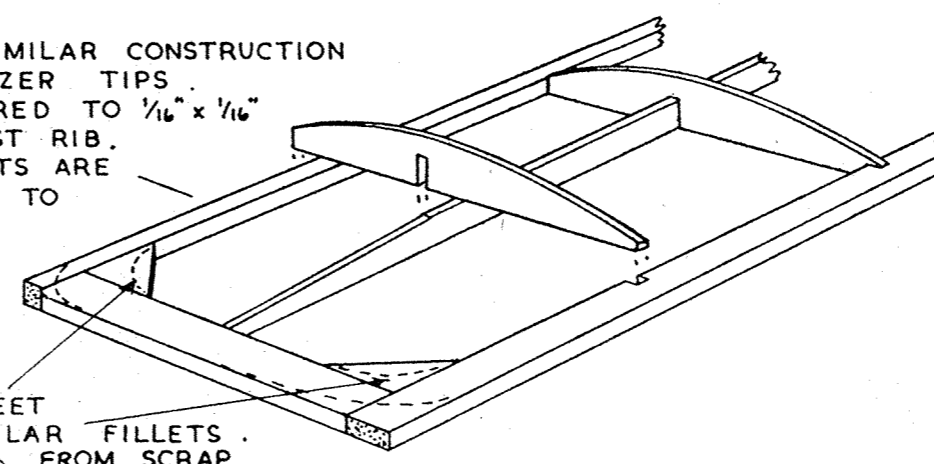

1/16" SHEET TRIANGULAR FILLETS FROM SCRAP & 1/16" x 1/4".

L/EDGE IS 3/32" x 3/32"

THREE SKETCHES SHOWING PROGRESSIVE ASSEMBLY OF FUSELAGE. TWO SIDES ARE BUILT, THE SECOND IMMEDIATELY OVER THE FIRST, BOTH ON WAXED TISSUE OVER THE PLAN. WHEN JOINING TWO HALVES, CUT CROSSPIECES IN PAIRS. TOP SIDE HAS HORIZONTAL WING SUPPORT INSTEAD OF A CROSSPIECE.

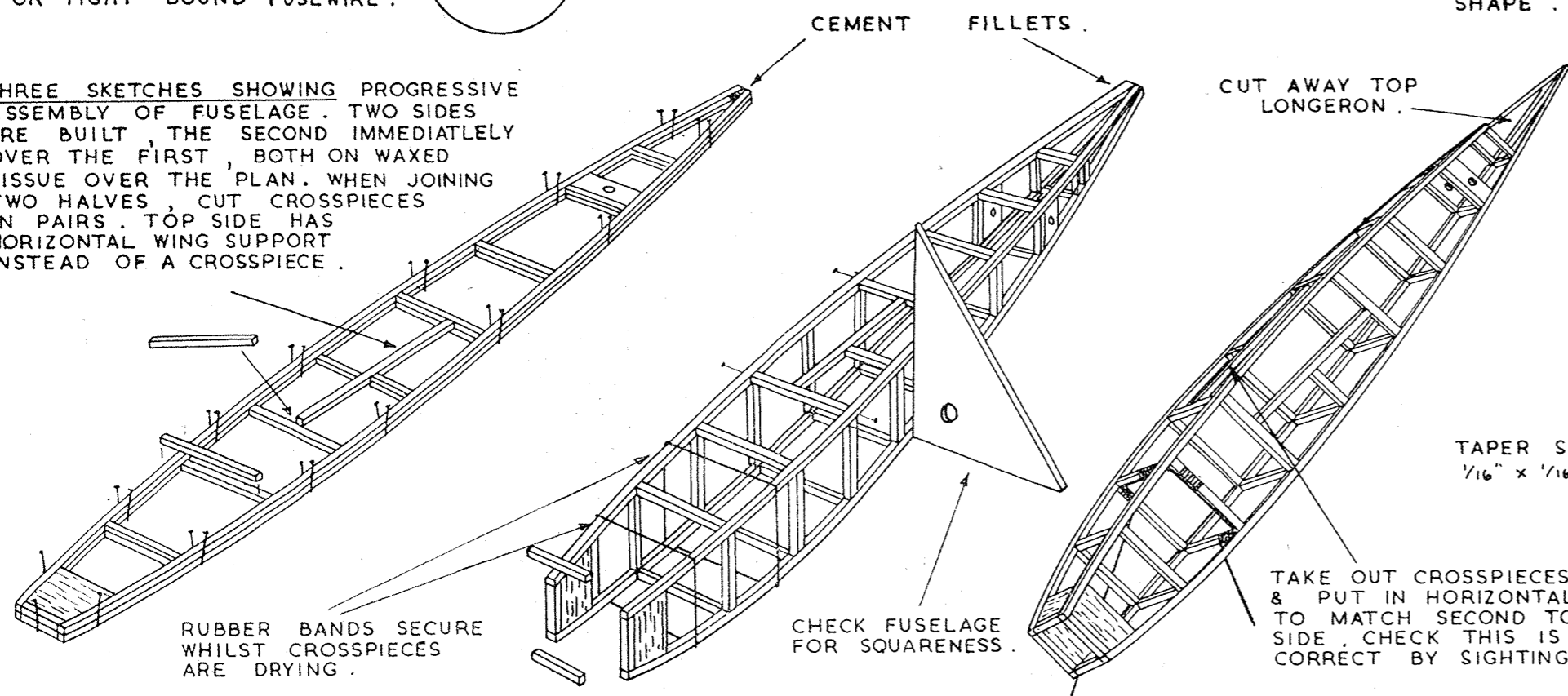

RUBBER BANDS SECURE WHILST CROSSPIECES ARE DRYING.

CHECK FUSELAGE FOR SQUARENESS.

TAKE OUT CROSSPIECES & PUT IN HORIZONTAL TO MATCH SECOND TOP SIDE. CHECK THIS IS CORRECT BY SIGHTING OVER PLAN.

TAPER SPAR TO 1/16" x 1/16" AT TIP.

1/16" x 1/4"

SPAR IS 1/8" x 1/16"

TRAILING EDGE IS 1/16" x 1/4".

SLOTS ARE 1/16" DEEP.

DIHEDRAL IS 2" AT EACH TIP.

LEADING EDGE IS 3/32" x 3/32". RIBS ARE BUTT JOINTED.

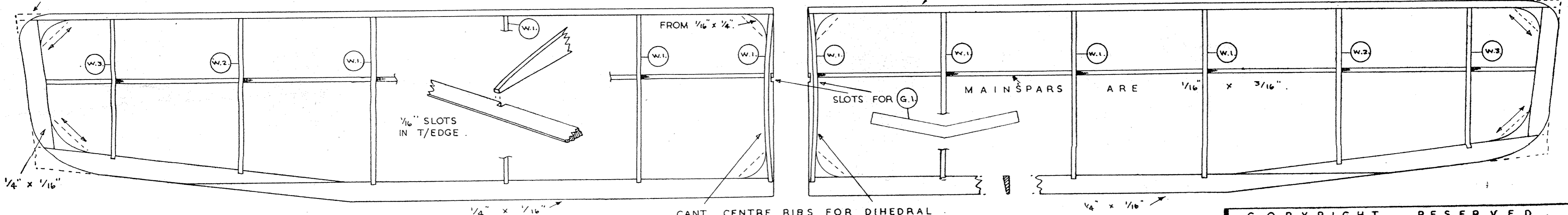

1/16" SLOTS IN T/EDGE.

CANT CENTRE RIBS FOR DIHEDRAL

1/4" x 1/16"

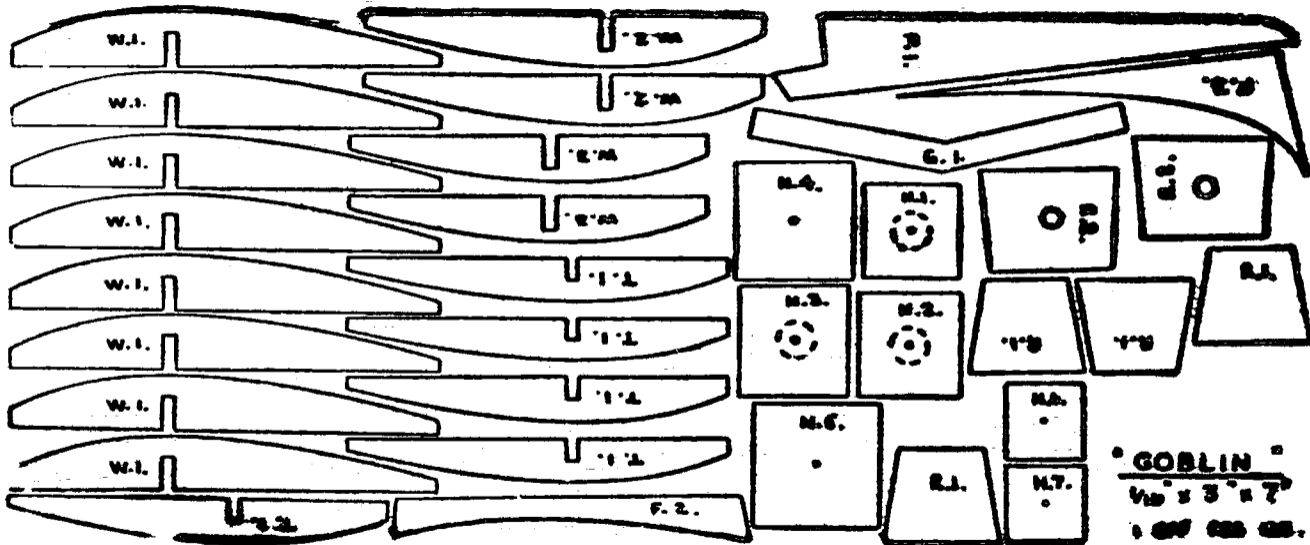

° GOBLIN °
 1/8" x 3" x 7"
 1 OFF 025 025.

VERON

GOBLIN

RUBBER DURATION MODEL

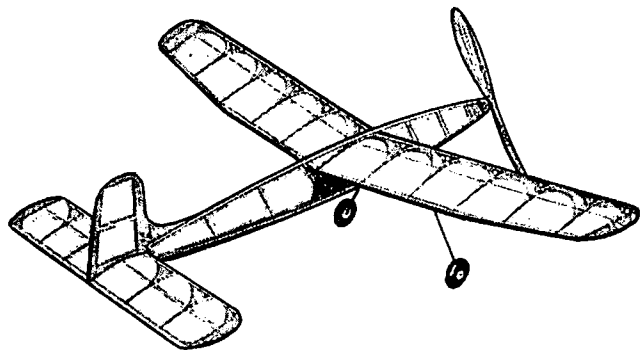

BUILDING INSTRUCTIONS

First, study the plan and identify all the parts on the 1/16" printed wood sheet. Familiarize yourself with these and all other instructions. The tools needed are small pliers, a few pins, either steel-backed razor blade or Balsa knife and fine sandpaper. The fuselage, wing and tail panels are built directly over the plan.

WINGS.

Lay the plan directly on the building board and cover with waxed tissue or greaseproof paper to protect from the cement. Pin on edge the two 12" lengths of 1/16" x 3/16" balsa above spar positions, and pin in place the leading and trailing edges. Pins are set either side of strips—not through the wood. Make good close fit of "scarf" joints in trailing edges. Cut 1/16" slots for ribs in trailing edges. Cement ribs in place. Centre two ribs are canted for dihedral. Add tips and small 1/16" scrap corner gussets. Allow to set hard and, when dry, remove from plan. Place trailing edge along edge of building board and sand to streamline section shown. Trim gussets and tips to give rounded contours and sand smooth. Lay one wing panel flat on board, cement centre section ribs firmly together with dihedral gusset G.1 in place and other tip supported on block 4" high—giving normal dihedral of 2" under each tip.

FUSELAGE.

Select four even quality longerons. Pin two in place over plan side elevation. Cut uprights in fours and cement one set in place. Add sheetings R.1 and R.2 level with bottom of longerons. Build second side immediately over first. Ensure R.1 and R.2 are level with top of longerons. Second side has horizontal strut in wing bay. When set, remove from plan and split apart with razor blade. Cement and temporarily pin in place four crosspieces to one fuselage panel at X and Y. Add other panel and likewise pin and cement—see drawing. Rubber bands around fuselage will retain whilst drying—check for squareness. Draw longerons together and cement at rear. Add other crosspieces. Likewise draw nose together. Add horizontal 3/32" x 3/32" for wing support on right hand side. Cut away top longeron in stern bay. Bend undercarriage 20 S.W.G. wire to shape and bind in position. Add wheels. Ensure that 1/4" dowel for rear rubber fixing is tight fit in holes R.2.

NOSE ASSEMBLY AND AIRSCREW.

Laminate together 1/16" balsa pieces N.1 to N.7 as shown in sketch. Trim and sand to fit tightly in fuselage. Drill hole and add metal nose ferrule, cementing firmly. Insert shaft and check for free running.

Locate airscrew on shaft with cup washer against rear face of airscrew to provide bearing against ferrule; bend shaft with two right angles as shown to engage into airscrew, cement firmly in place.

TAIL SURFACES.

Pin in place over plan three strips of balsa for leading edge, spar and trailing edge, sizes as shown. Add ribs and tips and corner gussets. When set remove from plan, sand trailing edge, then trim and sand tips to correct outline.

FIN.

Build directly over plan from parts F.1 and F.2 with all sizes of strips shown. F.3 is added later. Sand only the edges smooth and check for flatness.

COVERING.

Cut tissue into strips about 1/2" wider all round than the individual panels with grain lengthwise. Use tissue paste (Photo-paste) for adhesion and use sparingly. Rub tissue paste lightly over outer edges of individual wing panels, centre section to tips, undersides first. Stick tissue lightly to centre rib and stretch evenly towards wing tips, as well as tightly between leading and trailing edge. Obviate any warps by even tension. Complete opposite lower panel, then cover top sides likewise. Similarly cover tailplane, underside first. Cover fuselage from nose to stern each side separately in four strips.

Shrink tissue with water from a mouth or scent spray, do not brush with water. When quite dry, give one coat of thin shrinking dope to wings and tail surfaces and two to fuselage, noseblock and airscrew.

The model must be doped before the rubber motor is inserted and any attempt made to fly it.

ASSEMBLY.

Cement fin upright and very firmly to centre rib of tailplane, then cement tailplane to stern bay, checking alignment of fin by sighting along top of longeron. Add fairing F.3. Cut away tissue over wing slot and locate wing. This is retained only by rubber band around fuselage. Correct incidences are built into this model. Check that all surfaces are symmetrical and level with fuselage.

Join ends of rubber motor with a double "granny" knot so that loop untensioned is just 10 1/2" long. This will keep the motor tight between nose and tail, thus preserving the balance of the model on the glide. Lubricate the motor with commercial rubber lubricant. Tie length of cotton loop around end of rubber and let motor down into fuselage through nose. Engage rear end of motor with piece of 1/4" dowel—this can be seen clearly through tissue; pull out other end by means of cotton, and engage front end of motor with noseblock shaft.

Do not insert motor into an uncovered fuselage or structural failure will result.

FLIGHT TESTING.

Check for balance. Model should hang slightly nose down when supported by finger tips near root rib of wing about 50 per cent. of the wing chord back.

Choose a calm windless day for first flight tests in preferably a grassy field. Face into wind and gently launch the model slightly nose down, and observe the glide. The model should glide evenly and steadily downwards to the ground about 15 to 18 feet in front of you. Any tendency to stall (nose up with "see-saw" action) or diving should be corrected by moving wing from central position in slot slightly backwards or forwards respectively. Glide again, and if faults are still apparent, pack up leading or trailing edge of wing with small pieces of 1/32" or 1/16" balsa. Glide should be with a slight turn to the right, achieved by a thin strip of gummed paper tape adhered to trailing edge of the fin.

Now wind about 50 turns on to motor and launch model level into wind. The model should climb gently to the right before settling into an even glide. If satisfactory, wind up motor to 100, 150 and 200 turns for consecutive flights. If model tends to climb and stall with increased power, add slight downthrust by packing top of noseblock, but do not alter wing position or settings. Maximum safe turns on a lubricated motor will be about 350 to 400.

When you have successfully completed and flown this model, perhaps you would like to build something bigger and better. Ask your local VERON dealer to show you our more advanced competition designs.