

SPECIFICATION:

| | |
|-------------|--------------|
| WING SPAN | 30 ins. |
| LENGTH O.A. | 22 ins. |
| WING AREA | 118 sq. ins. |
| WEIGHT | 2½ ozs. |

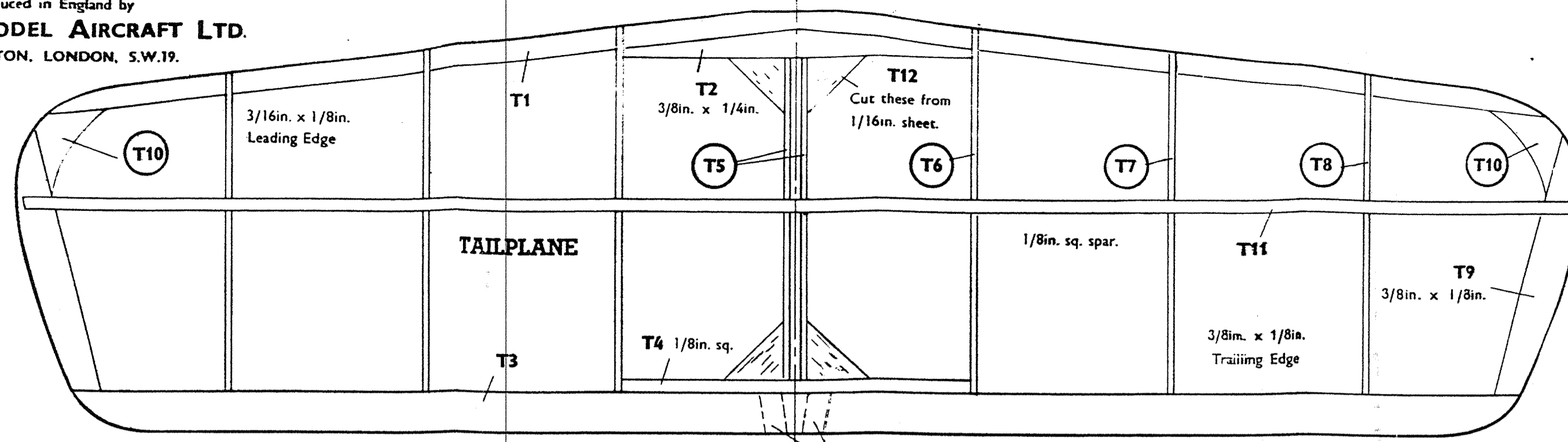

INTRODUCTION.
 This model incorporates very simple constructional methods, as most of the parts can be built directly over the plan. This kit follows the usual practice of supplying most of the parts cut to shape and numbered to correspond with the drawing, leaving very little shaping to be done. The pre-cut parts can be eased out of the panels with a balsa-knife, or a razor-blade broken in two to obtain a point.

Pin the drawing to a flat board to work on, and cover it with a sheet of greaseproof paper to protect it from the cement. Dope and cement are not included in this kit, but can be obtained at any model shop.

CONSTRUCTION.

FUSELAGE. This is a simple box-type structure, which can be built mainly over the plan. First build the two sides from 1/8in. square strips 1 and 2, and parts from sheet 1, as shown in Fig. 1. Duplicate the strips, and build the second side over the first, with a piece of tracing paper between them. Note the joint in the longerons, and 13 level with the upper ones at the rear. Cement strips 14, and cement them in place for the windscreen supports, followed by the front cowling parts 15. (One half is hinged as shown in Fig. 6.)

Remove the side frames from the plan, and cement bulkheads 5 and 6 in place, checking over the plan view for squareness, Fig. 2. Next cement the bulkheads 7, 8 and 9 in place, then cement the rear ends of the fuselage together, using thin elastic bands to hold them in place until set. Add the cross struts, half bulkhead 10, and stringer 11 of 1/8in. square. Fig. 3. Cement part 12 level with the lower longerons, and 13 level with the upper ones at the rear. Cut strips 14, and cement them in place for the windscreen supports, followed by the front cowling parts 15. (One half is hinged as shown in Fig. 6.)

Cut the tow-hook strip 16 to shape as shown. Bend the wire hook, bind and cement it to the strip 16, then cement this to the fuselage.

Cut the dowels 17 to length, and cement them against bulkheads 5 and 6, together with gussets 18. Next cut the 1/4in. x 3/32in. strips 19 to length, and cement them where shown in Fig. 7 to support the skid. This is fitted later. Bore up the under-fin from strip and cement it to the fuselage.

Mark the outline of the front bulkhead on the nose block 20, and carve it to the shape shown in the plan and side-views, as shown in Fig. 5. Fit it to the fuselage for final sanding. To complete the front end, cement the hardwood skid 21 in place, holding it with elastic bands. Taper it as shown to help bending. Cement the paper tube 22 against bulkhead 9, and reinforce it with gussets made from scrap balsa.

CABIN. It will be easier to fit this after the covering, but the following method should be used. First bend the celluloid to shape by gently creasing it where shown in the sketch. Apply cement to the top of bulkhead 5 and along the strips 14, and hold the windscreen in place until set. Then cement the sides.

WINGS. Build the two halves over the plan separately. First lay the leading and trailing edge W1 and W2 over the drawing, with pins placed either side where necessary. Then cement ribs W3-W8 in place, and tip pieces W9 cut from 3/8in. strip, together with gussets W10 from sheet 1. Taper the spar W11 at the tip, and cement it in place in the rib slots. When both sides are built, and the cement has set, remove them from the plan and trim the spars to length, making a lap joint of the main spar as shown. Lay the wing-halves over the lower drawing, raise the tips 2in. and assemble the centre-section, using the strips W12 and W13 as shown, shaping them after. Sandpaper the leading edge and tips to shape, and smooth down the whole structure.

TAILPLANE. Pin down the leading edge strips T1 and jointing strips T2, cut from 3/8in. x 1/4in. Then pin down T3 and T4, followed by ribs T5-8 and tips T9, cut from 3/8in. strip. T10 are ready-cut parts on sheet 1. Cement the spar T11 in the rib slots, and taper the ends. Fit the centre gussets T12 and sandpaper the leading edge and tips to shape.

FIN. This is built over the drawing, using parts F1 and F2 and strips where shown. Raise the outline with thin card, to centre it against the 1/8in. square strips. When assembled, sandpaper the edges of the fin to a streamlined section, and cement it to the tailplane.

COVERING. Cover the model with the paper supplied, in the following order—fuselage top and bottom, then sides. Wing and tailplane undersurfaces, then top. Fin, each side separately. Use office paste or dope for fixing it. Cut the paper to the approximate shapes first, leaving a 1/2in. margin all round. Apply paste to the edges of the frame, then lay the tissue over it and pull gently all round. Do not attempt to get it drum tight, but aim at getting an even surface, with no deep wrinkles. The water-spraying and doping will tighten it.

Before doping, lightly brush or spray each part with water and leave to dry. Spray half a wing at a time, and pin it down to a flat board to prevent warping while it is drying. Do the same with the tailplane. When they are completely dry, give each part a coat of dope, and pin down the wing and tailplane again, when the dope begins to dry. A coat of clear cellulose lacquer over the whole of the model is beneficial.

Painting should be restricted to the fuselage to save weight.

ASSEMBLY. Use two 2in. x 1/8in. elastic bands to hold the wing in place. They should be stretched diagonally over the centre-section and hooked over the dowels 17. For the tailplane, loop two 2in. x 1/16in. bands together to make one double length. Insert it through the tube 22 against a piece of wire, stretch both ends over the tail to the pin at the rear of the fuselage.

Check the rig of the complete model; the tailplane should be in line with the wing, and the fin upright. There should be no warps in the flying surfaces. If the model balances further back from the position shown on the drawing, add ballast weight to the nose; and if it is forward of this, add a small weight to the tail or raise the tailplane Trailing Edge.

FLYING. Choose a calm day if possible for the first tests. Hand-launch the model first to check the balance. If it shows a tendency to nose-up and stall, add more weight to the nose, or raise the tailplane Leading Edge; and if the model dives to the ground, take weight out of the nose, if any. If this fails to correct it, raise the tailplane Trailing Edge with a piece of card or 1/32in. balsa. This can be increased if necessary. It is almost impossible to know exactly what trimming a model will require until it is test-flown, but if the C. of G. is in the position shown on the drawing, and there are no warps in the wing or tailplane, the model should fly quite well straight away. A tendency for it to turn sharply either way indicates a warped wing, and this should be corrected. A wide turn is desirable to prevent the model flying too far in a straight line.

When a satisfactory glide is obtained, a tow-line launch can be attempted. For this, a length of thin kite string with a ring attached to one end is required. Tie a piece of tissue paper just below the ring to help it disengage from the hook on the model. Use a reel if possible to facilitate winding in the line. Un-reel the line, loop the ring on to the hook on the model, and get an assistant to launch it (into wind) while you reel in the line. A running launch can be used to save reeling in if desired. If the model is inclined to weave from side to side when being towed, pull it up slower and do not release it until it has levelled out to its normal gliding angle.

Do not forget to put your name and address on the model before flying.

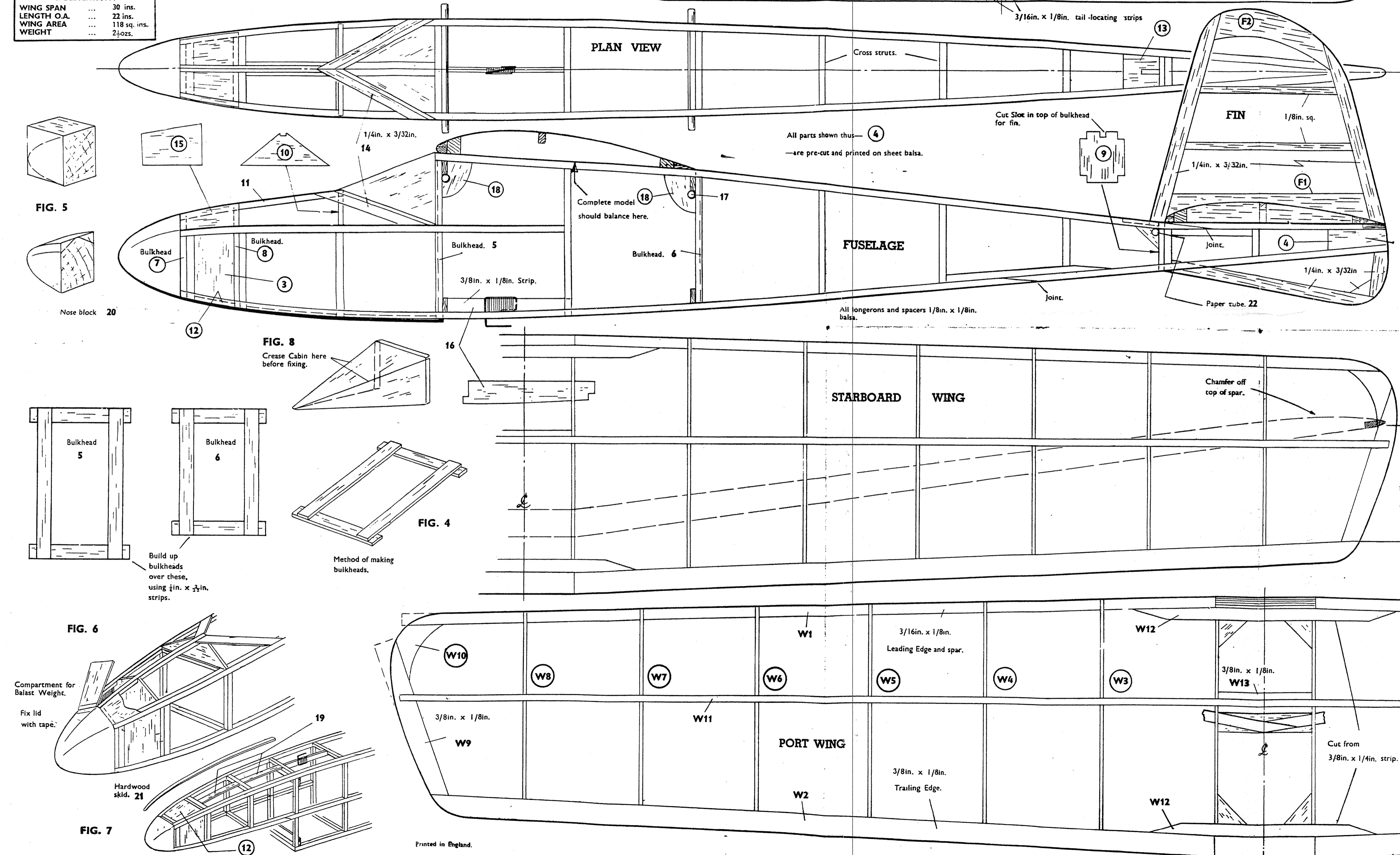

3 inch wide sheet

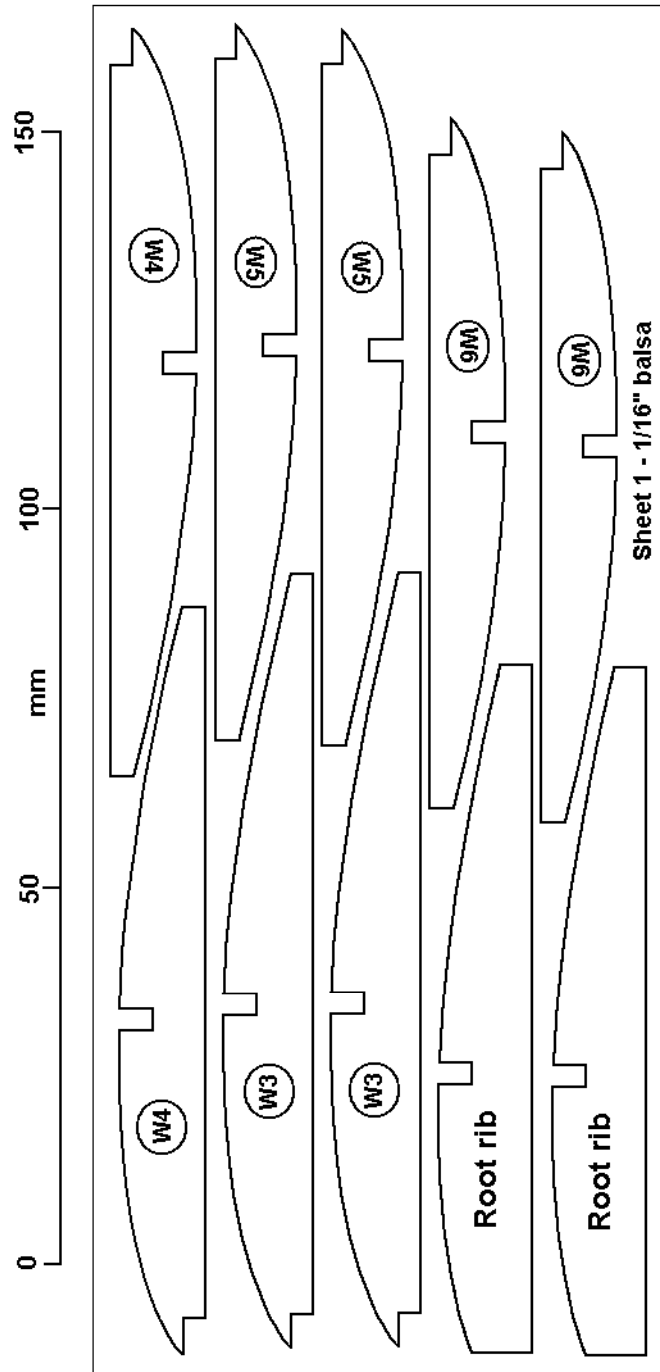

0 50 100 150
mm

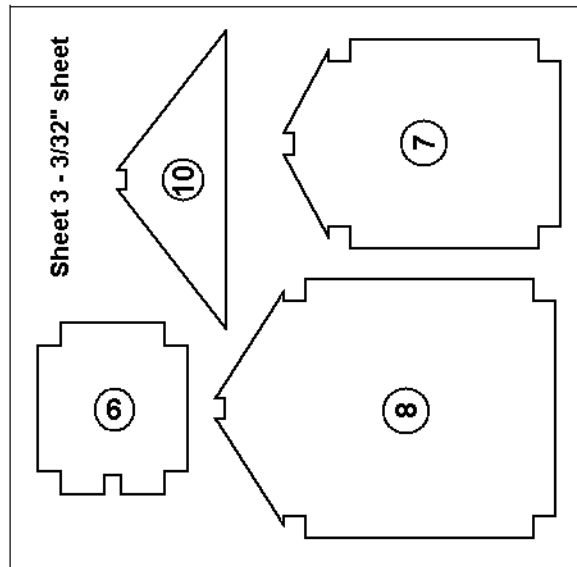
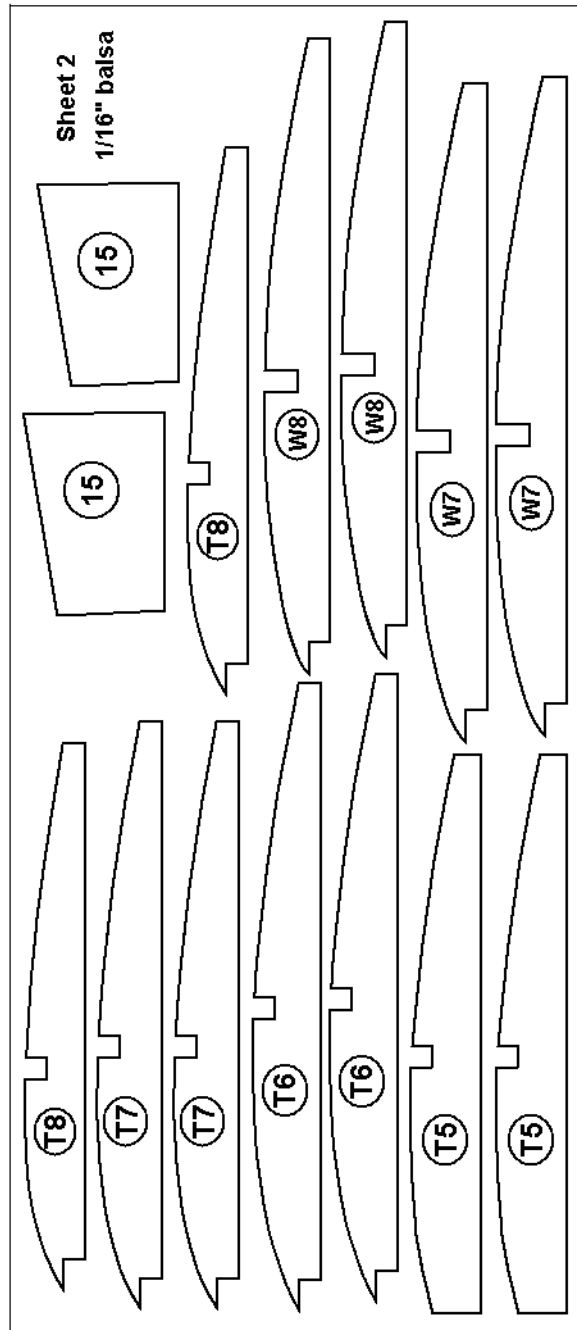

3 inch wide sheet

3 inch wide sheet

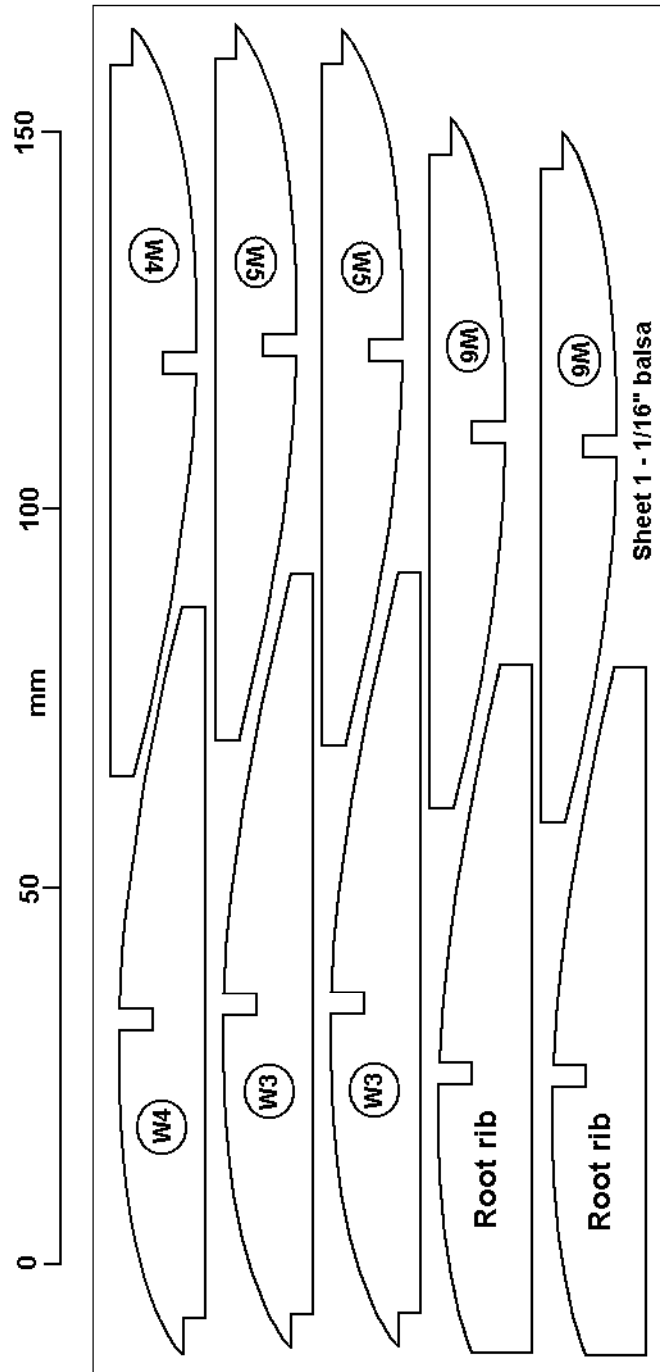

0 50 100 150
mm

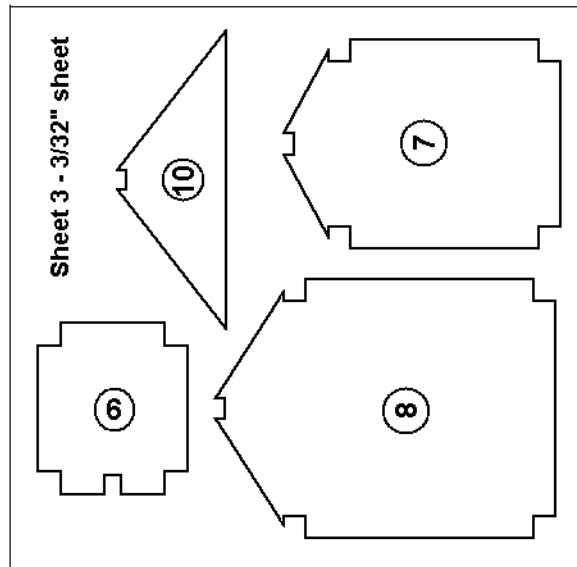
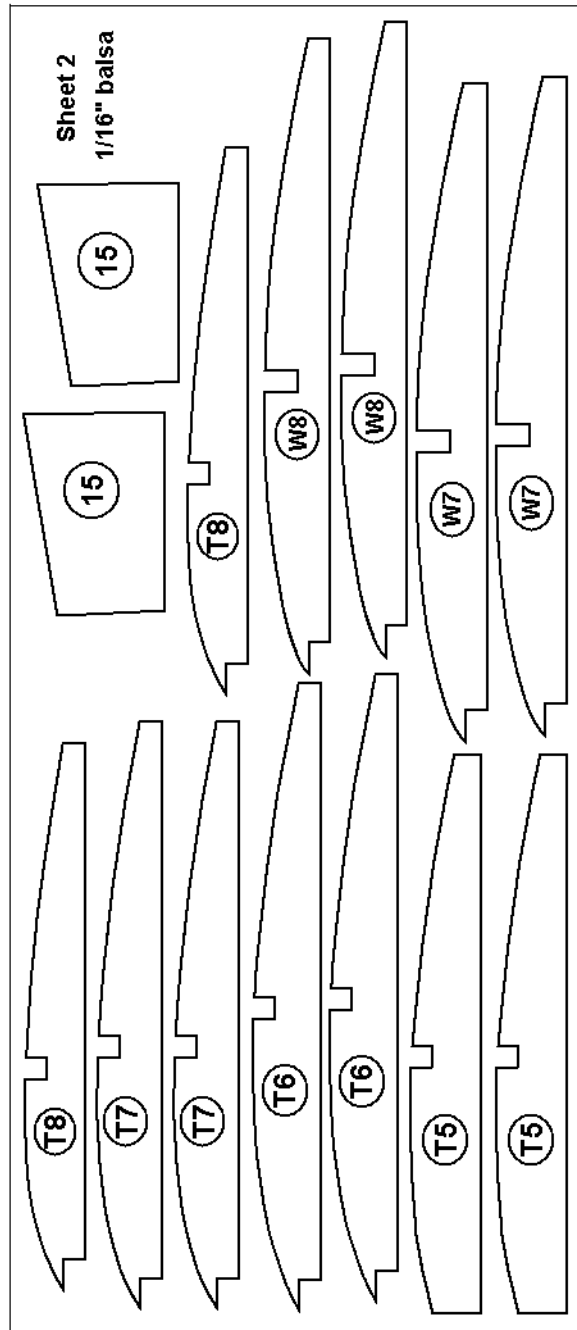

3 inch wide sheet