

to hold cylinder as damage could result from burrs being forced into the cylinder.

7. To remove the glow head from a hot engine —pour a little fuel slowly over the glow head to reduce the head temperature. Do not run it over the cylinder. The head will then release easily. A hot head will stick and forced removal may damage the cylinder.

8. Do not tighten the carburetor retainer nut more than enough to hold the carburetor from rattling. Overtightening will distort the front bearing and cause power drop and inconsistent running.

9. Tighten venturi nut only enough to hold needle valve body in position. Overtightening may strip the thread from the plastic carburetor body.

10. The needle valve body may be removed and replaced in the opposite position if desired.

E) PRESSURIZATION

Pressurizing is very critical when taken directly off the crankcase. On this engine pressurizing means have been provided and the rotary valve controls the pressure to normal operating limits. The hole in the pressure fitting on this engine is already started, but the hole will have to be drilled through the crankcase at this point before you can run on pressure. To rig for pressure observe the following steps:

1. Remove the back cover, cylinder, piston and rod assembly, venturi and needle valve assembly.

2. Rotate crankshaft until the port opening in the shaft points towards the pressure fitting on the right side of the black plastic carburetor body.

3. Continue drilling the hole already started in the pressure fitting through the crankcase. Use a #60 drill (.040 diameter).

4. Rotate crankshaft to deburr the drilled hole.

5. Flush crankcase and shaft thoroughly with methanol to remove all metal particles.

6. Lubricate shaft with light weight oil and reassemble engine.

The fuel tank **must** be air tight in order for the engine to operate properly on pressure. Be sure the tubing that connects the pressure fitting on the engine to the tank is also air tight. If the engine does not run smoothly air is getting into the pressure system. Check it thoroughly.

With pressure, the venturi may be opened to 5/32" on the .049 and .051 or 7/32" on the .09 engine to attain maximum power although the gain is very little.

(F) TO REMOVE CARBURETOR BODY FROM AN ENGINE:

1. Remove backplate, cylinder, and piston-rod assembly.

2. Remove spinner and engage prop screw approximately 3 or 4 threads in crankshaft.

3. With rear of crankcase on a hard smooth surface, tap prop screw with hammer until thrust washer disengages from crankshaft.

4. Unscrew carburetor retaining nut and slip carburetor body off.

5. To re-assemble engine, reverse above procedure. To re-press thrust washer onto crankshaft, put thrust washer face down on a smooth flat surface. Obtain a short length of wood dowel of a size that will fit into the intake hole of crankshaft. Tap dowel with hammer until thrust washer is fully seated on crankshaft.

WARRANTY

This engine is guaranteed against defects in materials and workmanship for 30 days from date of purchase. Glow heads are never guaranteed because of their delicate nature. No other guarantee is made or implied. If engine is returned to the factory within warranty, include 50c to cover cost of handling and return postage.

Do not take engine back to your dealer.

FACTORY REPAIR SERVICE

Minor repairs, examinations, or adjustments — \$2.50 plus parts. Complete overhaul (guaranteed new engine performance) .049 & .051 — \$8.00; .09 — \$9.50, including parts. On all C.O.D. shipments, purchaser pays postage and C.O.D. fees.

ENGINE SPEEDS (RPM)

The following speeds are typical of engines selected at random and run with Cox Competition Propellers (Metallic grey). Cox Racing Fuel was used for all tests. Temperature: 75°, Humidity: 46%, Altitude: 90 ft. above sea level.

PROP SIZE	TEE DEE .049	TEE DEE .051	TEE DEE .09
5" Dia. x 3 P	21,000	21,000	
5½" Dia. x 4 P	17,000	17,000	
6" Dia. x 3 P	18,500	18,500	
6" Dia. x 4 P	13,500	13,500	
7" Dia. x 3½ P			17,750

PARTS ORDER

Purchase parts from your dealer. If not available, order direct from factory. No C.O.D.'s please. Send remittance with your order. On orders less than \$2.00 add 35¢ handling charge. California residents, enclose applicable state sales tax.

Prices and design of parts subject to change without notice.

PARTS LIST PART	TEE DEE .049	TEE DEE .051	TEE DEE .09
	Cat. List No. Price	Cat. List No. Price	Cat. List No. Price
Glow Head & Gasket	1702 1.25	1702 1.25	2102 1.75
Needle Valve & Spring	1709 1.20	1709 1.20	2109 1.20
Prop Spinner & Screw	1718 .90	1718 .90	2119 1.20
Carburetor Body Only	1724 1.20	2024 1.20	2124 1.20
Cylinder, Piston & Rod	1775 4.75	2045 4.75	2175 5.75
Needle Valve Body & Venturi	1789 3.00	1789 3.00	2189 4.25
Crankcase, Crankshaft, Carburetor Body, Retainer Nut, Drive Plate, Crankcase Cover & Thrust Washer	1779 8.50	2049 8.50	2179 11.95

Order Parts by Catalog Number

Prices subject to change without notice.

L. M. COX MANUFACTURING CO., INC.

a subsidiary of LEISURE DYNAMICS, INC.
1505 East Warner Avenue, Santa Ana, Calif. 92705
© L. M. COX MANUFACTURING CO., INC., 1974
Litho in U.S.A. 11-75 R6 1759

CARE AND OPERATION OF YOUR



TEE DEE .049, .051, & .09 ENGINES

THIS ENGINE IS A VERY HIGHLY PRECISE CONTEST-TYPE ENGINE

Keep it immaculately clean, use Cox glow fuel or racing fuel and it will maintain its winning characteristics for a long period of time.

These engines will develop almost full power within one minute of running time; but a few, those which are slightly on the tight side, may not develop full power under one hour. Even these will develop sufficient power for average flying almost immediately. The only break-in required is a rich (slow) running with a recommended pitch propeller for the first few minutes. Gradually close the needle valve to peak operating RPM's for a short period, then run rich for a few minutes. Repeat this procedure for 5 to 15 minutes or until engine will hold top RPM.

NOTE: Your Tee Dee .049 engine develops its maximum H.P. at approximately 22,500 RPM. Use propellers that keep the RPM's below 24,000. Damage could result if engine is allowed to run above this figure.

(A) PREPARATION FOR RUNNING

1. Mount the engine in the plane, or if you want to give it some running first, mount it on a suitable mount. Do not hold the engine directly in a vise. Use A-Fig. 2, or A-Fig. 3 as a template to drill mounting holes.

2. Place propeller on the shaft with the flat side of the blades toward engine and lock securely with the propeller screw.

3. Procure a fuel tank from your local hobby dealer and connect the tank outlet to the carburetor fuel inlet nozzle. Best results will be obtained by mounting the tank close to the engine and with the average fuel level at the same height as the carburetor venturi.

4. Procure a 1½ volt Cox dry cell battery, or equivalent, and connect it with 2 flexible insulated wires to the glow plug clip as shown in the diagram A and B — Fig. 1. Do not use a stronger battery. If you do, the plug will burn out. The connections should be soldered to insure good contact, and taped to prevent bare ends of wire from getting together and "shorting" the battery. Be sure the battery is a good one. Your dealer sells batteries and glow plug clips. The Cox plastic mounted glow plug clip (Cat. No. 755-6) with wires already attached is recommended and requires no soldering.

5. Balance and trim propeller. This is very essential for good performance. Sand off any bead

of plastic along the edges of the blades. Fit a drill or shaft through the hole and rest the shaft on razor blades set in wooden blocks as shown in C-Fig. 1. Sand the heavy blade until the propeller will balance in a horizontal position. Care must be taken to do the sanding without spoiling the airfoil characteristics of the propeller blades. Caution: Use only nylon or wooden props. Styrene props are extremely dangerous on these engines.

(B) STARTING THE TEE DEE ENGINES

No matter how expert you are with small engines you will have better luck with these engines if you follow directions exactly as listed and do each operation in the exact order given.

1. Close the carburetor needle valve, B-Fig. 2, or B-Fig. 3, by turning it clockwise until it stops. Do not force it.

2. Fill the tank with Cox fuel.

3. Open the needle valve (counter clockwise) exactly 4½ turns for the .049 and .051 or 3½ turns for the .09 engine.

4. If the fuel level in the tank is lower than the carburetor venturi, put your finger over the air intake of the engine and pull the prop through compression until the fuel hose is full. Use a clear plastic fuel line so this can be checked visually. If the tank is mounted so the fuel level is higher than the carburetor the hose will fill itself when the needle valve is opened.

5. Connect the battery by snapping the clip on the glow head B-Fig. 1.

6. Squirt a few drops of fuel into the exhaust ports and immediately flip the propeller over counter clockwise. For quick starting the propeller must be flipped quite vigorously. The engine should start instantly if it has been primed with the correct amount of fuel in the exhaust port.

7. When the engine starts it will be running very rich and slow. The first time the engine is started let it continue to run rich for a period of 60 seconds. After approximately 60 seconds, slowly close the needle valve clockwise to the best running position and remove the battery connection. Subsequent starts may be adjusted to best running position immediately.

8. If starting is delayed for any reason, close needle valve, otherwise engine will become flooded. This precaution is only necessary if the tank is mounted so the fuel level is higher than the carburetor.

(C) FAILURE TO START

1. If the engine coughs and spits a bit of fuel spray from the exhaust, it is too rich. Close the needle valve and continue cranking until engine starts briefly. Open the needle valve again and

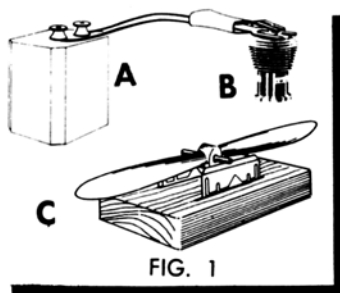

**FULL SCALE VIEWS OF THE TEE DEE
.049 AND .051
FOR INSTALLATION INFORMATION**

SPECIFICATIONS

	TEE DEE .049	TEE DEE .051	TEE DEE .09
Weight	1.48 oz.	1.48 oz.	2.72 oz.
Bore	.406"	.410"	.497"
Stroke	.336"	.386"	.471"
Displacement	.0499 cu. in. 819 cc	.0509 cu. in. 835 cc	.0913 cu. in. 1,497 cc

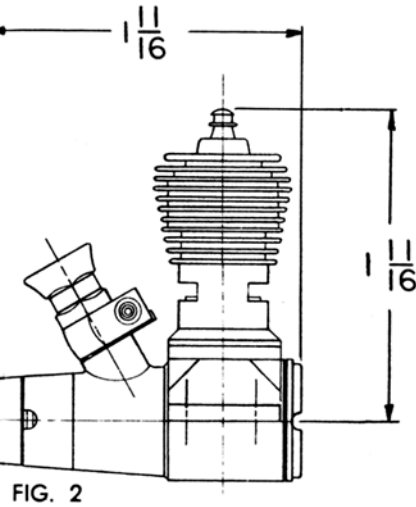
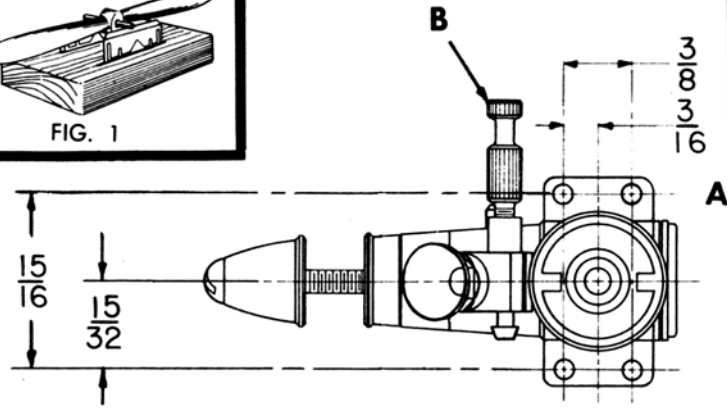

FIG. 2

crank it over. It should start immediately. Blowing into the exhaust ports between flips will help clear the excess fuel out of the glow plug.

2. If it starts up with lots of power and dies immediately it is too lean. Open the needle valve a half turn, prime the engine, and crank it over again. If the trouble persists and the tank is lower than the carburetor try choking again as in Section B Par. 4. If the engine hasn't been run for some time it is possible that thick castor oil is clogging the jets. Choking will clear this out.

3. If the engine still persists in above action it is possible the carburetor jets are stopped up. Remove the venturi nut and needle valve body. Three tiny jet holes will be found in the groove around the venturi tube. Clean these jet holes

with a piece of fine wire. Reassemble and the engine should run.

4. If the engine refuses to fire at all, screw the glow plug out and connect it to the clip. If the little coil inside does not get red hot, it is either burnt out or the battery is dead or the connections are made incorrectly. Replace the battery or the plug, or correct the connections. Glow plugs are **never** guaranteed. Do not return the engine to the factory for a burnt out glow plug because the cost to you will be excessive. Buy one from your dealer.

5. If you are not using Cox fuel, try it. **Never use gasoline or gasoline type fuels.**

(D) OPERATING TIPS AND ENGINE CARE

1. The glow plug is built right into the head

**FULL SCALE VIEWS OF THE TEE DEE .09
FOR INSTALLATION INFORMATION**

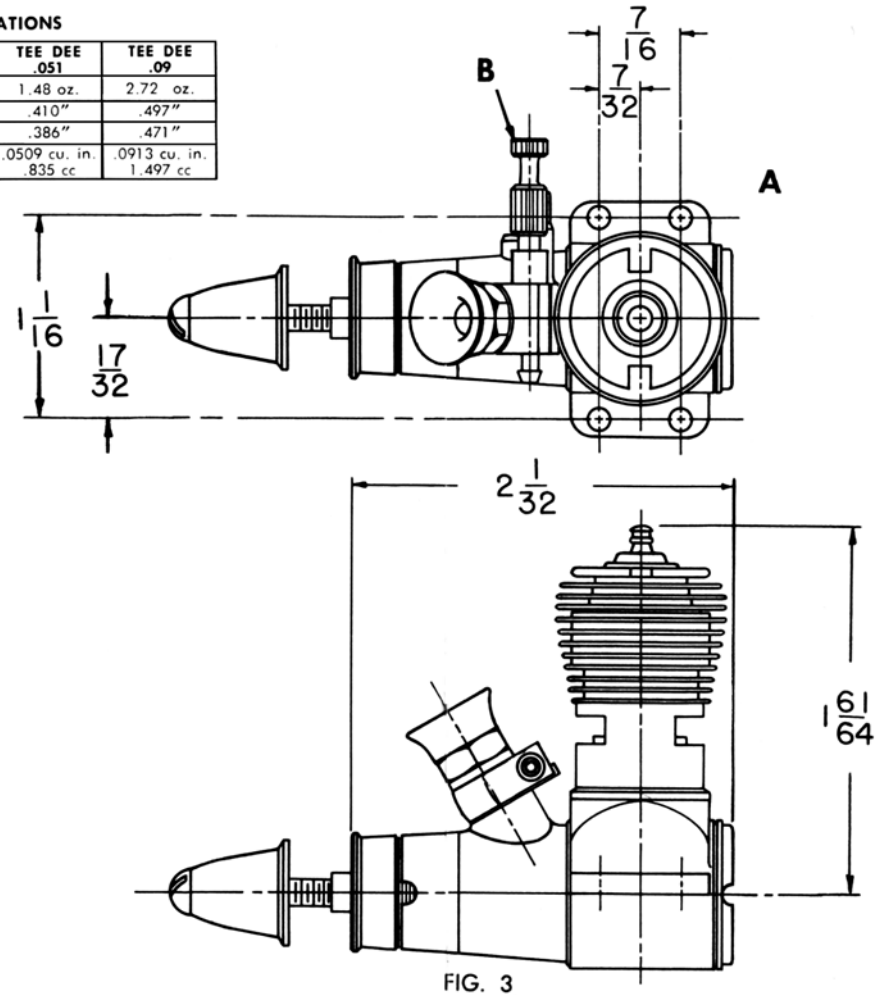

FIG. 3

in one unit. When the plug burns out just replace the entire head at the regular glow plug price.

2. After the last run, oil the engine with a light oil (SAE 10 is good) and wrap it with cloth or otherwise protect it from dust and dirt.

3. If the engine gets dirt in it through crack-up or otherwise, do not run it until it is thoroughly cleaned. **Take it apart**, wash it, oil it, and reassemble.

4. If the engine gets tight it is not frozen up. Do not send to factory. A new engine will sometimes tighten up a few times, especially after slow runs. This is more likely to happen, and will occur more often to an engine that is properly fitted, and has properly smooth wearing surfaces. Do not run it tight. The tightness is caused by a shallac-like deposit on the cylinder wall. Screw the head

off. **Remove the cylinder** and scour the inside wall very lightly with a bit of fine or medium steel wool. Wash, oil, and replace. The engine will then turn over freely and run properly. **Never** use sandpaper, emery cloth, or abrasives of any kind, or scrapers. Such methods will ruin the cylinder. Steel wool will not harm the bore.

5. Certain kinds of weather, especially warm humid (sticky) weather will cause excessive shel-lacking in a new cylinder. There is no known way to eliminate this nuisance and the smoother the fit the more susceptible is the engine to this trouble.

6. Do not tighten the head too firmly. Set it up just snug. Before removing head allow it to cool so it will loosen more easily. Use both wrenches when removing glow head. The top fin has flats for this purpose. Exhaust port should not be used