

# ULTRA SPORT 60

## INSTRUCTION BOOK



PLEASE READ THROUGH THIS INSTRUCTION BOOKLET IN ITS ENTIRETY BEFORE BEGINNING ASSEMBLY. IT CONTAINS IMPORTANT INSTRUCTIONS AND WARNINGS CONCERNING THE ASSEMBLY AND USE OF THIS MODEL.

**WARNING! THIS IS NOT A TOY! THIS IS NOT A BEGINNER'S AIRPLANE!**

This R/C kit and the model you will build is not a toy! It is capable of serious bodily harm and property damage. IT IS YOUR RESPONSIBILITY AND YOURS ALONE to build this kit correctly, properly install all R/C components and flying gear (engine, tank, pushrods, etc.) and to test the model and fly it only with experienced, competent help, using common sense and in accordance with all safety standards as set down in the Academy of Model Aeronautics Safety Code. It is suggested that you join the AMA to become properly insured before you attempt to fly this model. IF YOU ARE JUST STARTING R/C MODELING, CONSULT YOUR LOCAL HOBBY SHOP OR WRITE TO THE ACADEMY OF MODEL AERONAUTICS TO FIND AN EXPERIENCED INSTRUCTOR IN YOUR AREA.

Academy of Model Aeronautics  
5151 East Memorial Drive  
Muncie, IN 47302-9252  
(800)435-9262



P.O. BOX 788

URBANA, ILLINOIS 61801

(217)398-8970

## TABLE OF CONTENTS

<b>INTRODUCTION</b> .....	<b>3</b>	Install Wing Fairings .....	<b>30</b>
Precautions .....	3	Install Wing Fillets .....	31
Abbreviations .....	3	Shape Fin Fillets .....	<b>32</b>
Decisions You Must Make .....	4	Mount Stabilizer and Fin .....	<b>33</b>
Other Items Required .....	4	Install Servos, Horns & Pushrods ...	34
Supplies and Tools Needed .....	4	Control Surface Throws .....	35
Die Patterns .....	5	<b>FINISHING</b> .....	<b>36</b>
Types of Wood .....	6	Additional Fuelproofing .....	36
Get Ready to Build .....	6	Seal Off Cockpit .....	36
<b>TAIL FEATHERS</b> .....	<b>6</b>	Prepare Canopy .....	36
Fin and Rudder .....	6	Balance Airplane Laterally .....	36
Stabilizer and Elevator .....	7	Final Sanding .....	37
Install Hinges .....	8	Covering .....	37
<b>WING ASSEMBLY</b> .....	<b>8</b>	Glue the Hinges .....	37
Join Wing Panels .....	13	Install Pilot .....	38
Install Aileron Torque Rods .....	13	Glue Canopy in Place .....	38
Sand "Flats" on LE and TE .....	14	Wing Seating .....	38
Fiberglass Center Section .....	14	Re-install Engine & Radio .....	38
Install Wing Tips .....	15	Balance Your Model .....	39
Install Ailerons .....	16	Final Hookups and Checks .....	39
Install Wing Dowels .....	16	<b>PRE-FLIGHT</b> .....	<b>40</b>
Install Wing Bolt Plate .....	17	Charge Batteries .....	40
Fill Landing Gear Slots .....	17	Find a Safe Place to Fly .....	40
Installing Retracts .....	17	Ground Check .....	40
<b>FUSELAGE ASSEMBLY</b> .....	<b>18</b>	Range Check .....	40
Prepare Fuse Sides .....	18	Engine Safety Precautions .....	40
Assemble Lower Fuselage .....	19	<b>AMA SAFETY CODE</b> .....	<b>41</b>
Drill Engine Mount .....	21	<b>FLYING</b> .....	<b>41</b>
Install Servos, Guide Tubes .....	22	Takeoff .....	41
Mount the Wing to the Fuse .....	23	Flying .....	41
Fit Fuel Tank, Fuelproofing .....	25	Landing .....	41
Install Turtle Deck .....	25	<b>FLIGHT TRIMMING</b> .....	<b>42</b>
Assemble Nose Section .....	27	<b>NOTES</b> .....	<b>45</b>
<b>FINAL ASSEMBLY</b> .....	<b>30</b>	<b>PARTS LIST</b> .....	<b>46</b>
Sand Fuselage .....	30	<b>2-VIEW DRAWING</b> .....	<b>48</b>

Please inspect all parts carefully before starting to build! If any parts are missing, broken or defective, or if you have any questions about building or flying this airplane, please call us at (217) 398-8970 and we'll be glad to help. If you are calling for replacement parts, please look up the part numbers and the kit identification number (stamped on the end of the carton) and have them ready when calling.

## INTRODUCTION

Congratulations! Thank you for purchasing the Great Planes **Ultra Sport 60!** Jim Feldmann's original design was featured as a construction article in the August, 1989 issue of RC Modeler magazine, and has been hailed by many as "the best sport flying airplane ever"! The design starts with the legendary "Kaos" wing platform, and features modern styling and state-of-the-art construction techniques. The result is an ultra-stable, ultra-smooth flying airplane that does what you want it to, no more and no less.

The Ultra Sport 60 is easy to build, totally predictable, smooth-flying and has very docile stall characteristics, making it the ultimate sport airplane for the modeler who wants to fly with a higher degree of precision. Because it naturally tracks through maneuvers better than other sport airplanes, you'll fly better when you're flying an Ultra Sport 60.

This is not a beginner's airplane! While the Ultra Sport 60 is easy to build and flies great, we must discourage you from selecting this kit as your first R/C airplane. It is fast, highly maneuverable, and lacks the self-recovery characteristics of a good basic trainer such as the Great Planes PT Series airplanes. On the other hand, if you have already learned the basics of R/C flying and you are able to safely handle an "aileron trainer" airplane such as the Great Planes Trainer Series or Big Stick Series airplanes, the Ultra Sport 60 is an excellent choice.

## PRECAUTIONS

1. You must build the plane **according to the plans and instructions.** Do not alter or modify the model as represented by the plans, as doing so may result in an unsafe or unflyable model. In a few cases the plans and instructions may differ slightly from the photos. In those instances you should assume the plans and written instructions are correct.
2. You must take time to **build** straight, true and strong.
3. You must use a proper R/C **radio** that is in first class condition, the correct sized **engine** and correct **components** (fuel tank, wheels, etc.) throughout your building process.

4. You must properly **install** all R/C and other components so that the model operates properly on the ground and in the air.
5. You must test the operation of the model before the first and each successive flight to insure that all equipment is operating, and you must make certain that the model has remained structurally sound. Be sure to check the nylon clevises and horns often, and replace if they show signs of wear.
6. You must **fly** the model **only with the competent help** of a well experienced R/C pilot if you are not already an experienced and knowledgeable R/C pilot at this time.

Note: We, as the kit manufacturer, can provide you with a top quality kit and great instructions, but ultimately the quality and flyability of your finished model depends on how **you** build it; therefore, we cannot in any way guarantee the performance of your completed model, and no representations are expressed or implied as to the performance or safety of your completed model.

**Remember: Take your time and follow directions to end up with a well-built model that is light, straight and true.**

INSTRUCTIONS IN BOXES LIKE THIS ARE VERY IMPORTANT AND SHOULD BE FOLLOWED CAREFULLY

## COMMON ABBREVIATIONS USED IN THIS BOOK AND ON THE PLANS:

Elev = Elevator  
Fuse = Fuselage  
LE = Leading Edge (front)  
**LG** = Landing Gear  
Lt = Left  
Ply = Plywood  
Rt = Right  
Stab = Stabilizer  
TE = Trailing Edge (rear)  
Tri = Triangle  
= Inches

# DECISIONS YOU MUST MAKE NOW

## ENGINE AND MOUNT SELECTION

The recommended engine size range is as follows:

.60 - .65 cubic inch displacement 2-cycle

.70 - .91 cubic inch displacement 4-cycle

The engine you select will determine how you build the fuselage, so it is important that you have the engine close at hand while building.

This kit includes the new Great Planes Adjustable Engine mount. This mount will work on most .40-.60 2-Cycles and .40-.70 4-cycles. Cut or break the "spreader bar" off each mount half. The surfaces where the spreader bars were attached need to be very smooth to allow the mount halves to fit together. Snap the two mount halves together. Slide the mount halves apart until the engine mounting lugs will sit flat on the beams.

**NOTE:** If you choose to power your Ultra Sport 60 with a 4-cycle engine, keep in mind that the RPM of your engine will be considerably less than that of a 2-cycle engine; therefore, you should select a **higher pitch propeller** to keep the speed and overall performance roughly equivalent to that of a 2-cycle engine. For example, an 11x7 or 11x8 prop would be used with a .61 (2-cycle) engine; but an 11x11 prop may be the best choice for a .91 4-cycle engine.

## LANDING GEAR CONFIGURATION

The Ultra Sport 60 may be built with a "**taildragger**" or "**tricycle**" landing gear configuration, and a **retractable main** gear may be installed if you want to really "clean up" this airplane for ultra-smooth and precise aerobatics.

There is not, however, room for a nose gear retract; therefore, if you want retracts, you'll have to use the "tail-dragger" configuration.

## OTHER ITEMS REQUIRED

- Four-channel radio with 4 servos (additional channel and retract servo required if retracts are being used).
- Propellers (see engine instructions and above engine notes for recommended sizes).
- Spinner (2-3/4" diameter)
- Fuel Tank (11 to 14 ounce)
- Main Wheels\* - 2 (2-1/2" dia. for fixed gear and retract)
- Nose Wheel\* - 1 (2-1/2" diameter, required for trike only)
- Tail Wheel - 1 (1" diameter, required for taildragger only)
- 5/32" Wheel Collars - 4 or 6
- 3/32" Wheel Collars - 2 (required for taildragger only)
- Iron-on Covering Material
- Silicone Fuel Tubing
- Wing Sealing Tape (or silicone sealer ... see instructions)
- Latex Foam Rubber Padding (1/4" thick)
- Dubro "E-Z Connectors" (or equivalent) - 2
- Main Gear Retracts: (optional)
  - Mechanical: Dave Brown 2-Gear Main, or equivalent
  - Pneumatic: Robart #605 90-degree mains, or equivalent (requires #188 air control kit)
- Plastic Pilot (Williams Bros. 2-5/8" scale)

•"Lightweight wheels are recommended.

## SUPPLIES AND TOOLS NEEDED

- 2 oz. Thin CA Adhesive
- 2 oz.** Medium or Thick CA Adhesive
- 2.5 oz. 30-Minute Epoxy
- Hand or Electric Drill
- Drill Bits: 1/16", 5/64", 3/32", 7/64", 1/8", 9/64", 5/32", 13/64", 7/32", and 1/4"
- Sealing Iron
- Heat Gun
- Hobby Saw (Xacto Razor Saw)
- Xacto Knife, #11 Blades
- Pliers
- Screw Drivers
- T-Pins
- Straightedge
- Masking Tape
- Sandpaper (coarse, medium, fine grit)\*
- T-Bar Sanding Block, or similar
- Waxed Paper
- Lightweight Balsa Filler
- 1/4-20 Tap, Tap Wrench
- Vaseline Petroleum Jelly
- Isopropyl Rubbing Alcohol (70%)
- 3M "77" Spray Adhesive (optional)
- Dremel Moto Tool or similar (optional)

\*NOTE: On our workbench, we have four 11" T-Bar sanders, equipped with #50, #80, #100 and #150-grit sandpaper. This setup is all that is required for almost any sanding task. We also keep some #320-grit wet-or-dry sandpaper handy for finish sanding before covering.

# DIE DRAWINGS

Use this drawing to help you identify the die-cut parts

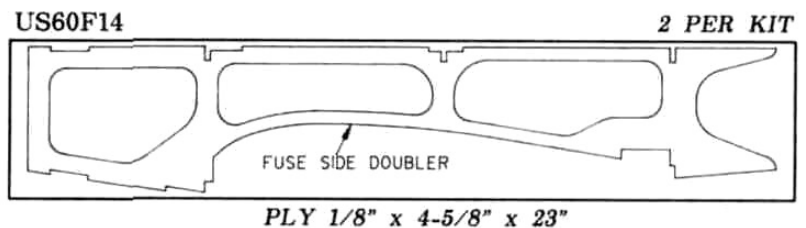
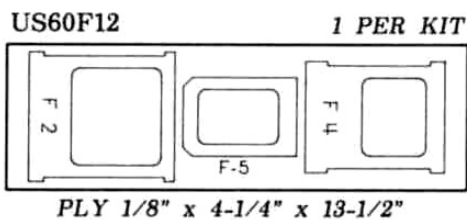
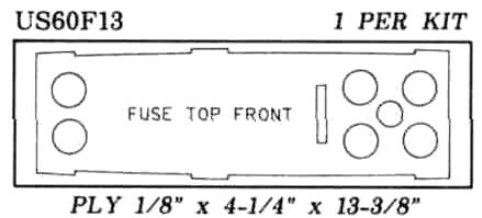
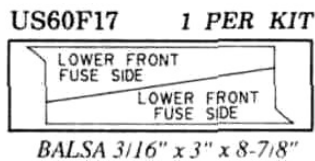
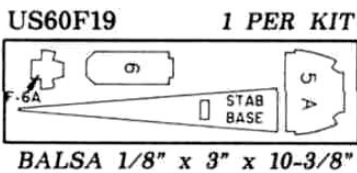
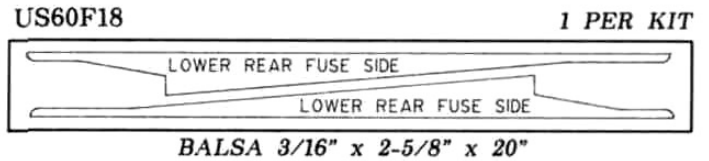
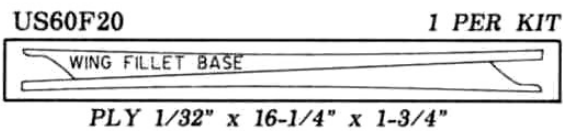
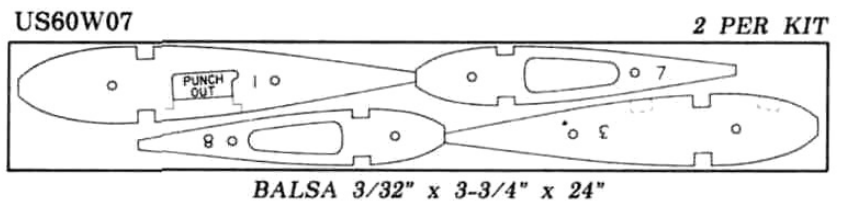
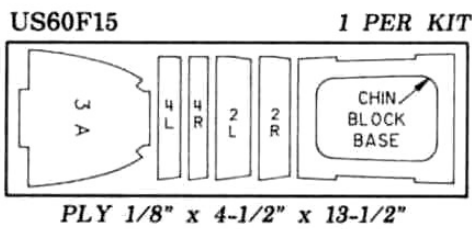
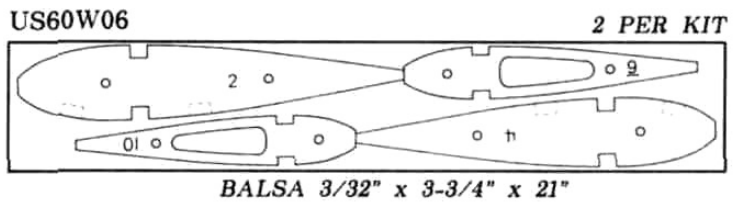
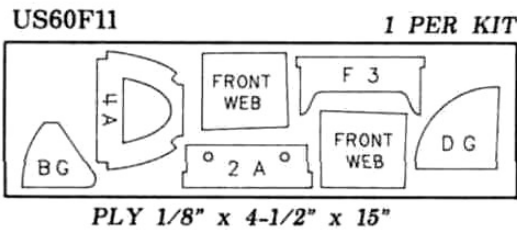
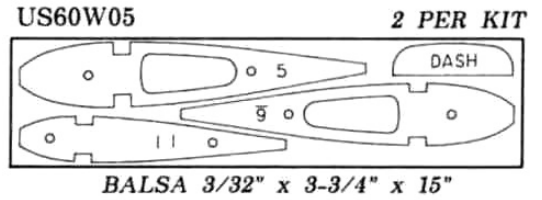
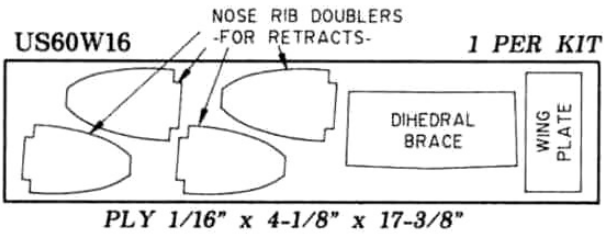

## TYPES OF WOOD

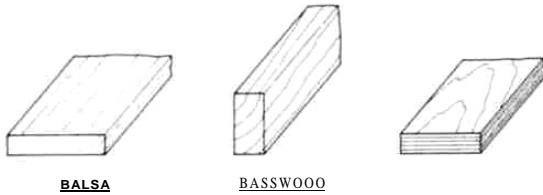

## GET READY TO BUILD

1. Unroll the plan sheets. Re-roll them inside out to make them lie flat. NOTE: You may cut the fuselage plan into two sections for ease of building on the "Bottom View," by cutting along the "cut line" shown on the plan.
2. Remove all parts from the box. As you do, figure out the name of each part by comparing it with the plans and the parts list. Using a felt tip pen, write the part name or size on each piece to avoid confusion later. Use the die-cut patterns shown on page 5 to identify the die-cut parts and mark them before punching out. Save all scraps. If any of the die-cut parts are difficult to punch out, do not force them! Instead, first cut around the parts with an Xacto knife. After punching out the die-cut parts, use your T-Bar or sanding block to lightly sand the edges to remove any die-cutting irregularities.
3. As you identify and mark the parts, separate them into groups, such as **fuse** (fuselage), **wing**, **fin** and **stab** (stabilizer), and **hardware**.

## "TAIL FEATHERS"

### BUILD THE FIN AND RUDDER

1. Find the following parts: **5/16" balsa fin front, fin rear, rudder front, rudder rear** and **rudder bottom**. Compare the parts to the plans to make sure you have the correct parts. Also find the 5/16" x 5/8" x 5-3/4" balsa stick, and the 1/8" x 3/8" x 11-7/8" balsa stick.
2. Cut the 1/8" x 3/8" x 11-7/8" balsa stick into 5 pieces having lengths of: 2-7/8", 2-7/8", 1-5/8", 1-5/8" and 2-3/4". The 2-3/4" length is the rudder end. The remaining pieces are the elevator ends.

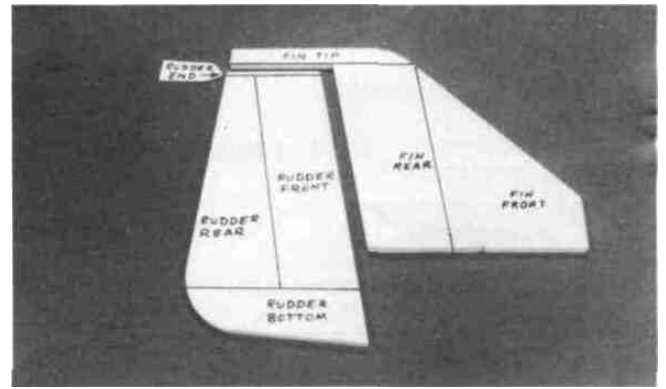

3. Working on a flat surface covered with waxed paper, glue the **fin front** to the **fin rear**, then glue on the **fin tip**. Sand the front of the fin tip to blend with the fin, as shown on the **plan**.
4. Using a T-bar or sanding block, sand both sides of the fin smooth. Then sand the leading edge and top edge to a **rounded** shape, as shown on the plan. Draw a **centerline** along the trailing edge of the fin to mark the hinge line.
5. Glue the **rudder front** to the **rudder rear**, then glue on the **rudder bottom** and **rudder end**.
6. Draw a centerline all around the edges of the rudder.

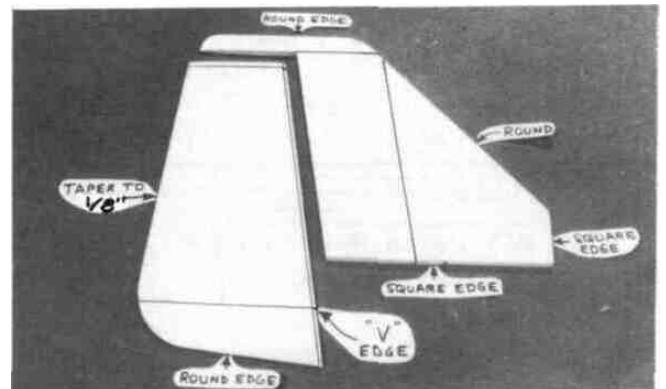

7. Using a sanding block and **coarse** (50 or 80-grit) sandpaper, sand both sides of the rudder to a **taper** as shown on the plans. The trailing edge should end up approximately 1/8" wide and have a rounded shape. (Do not sand to a sharp edge). Sand the bottom edge to a rounded shape. Sand the leading edge to a "**V-shape**" as shown on the plan.
8. Hold the fin and rudder together and mark the fin tip at the rudder trailing edge. Cut off the fin tip and sand it to match the rudder as shown on the plan.
9. If you are building a "tailedragger", check the plans and mark the location of the tailgear on the rudder. Drill a

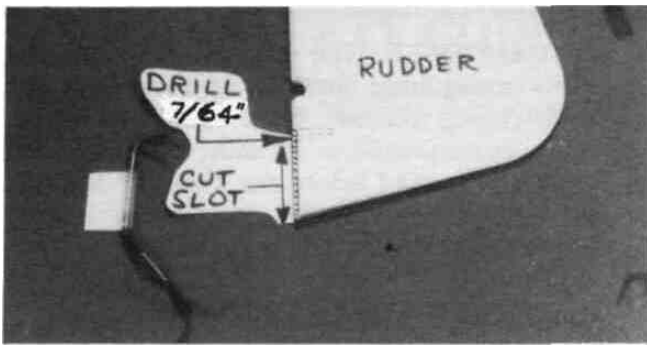

7/64" hole in the rudder, and groove the rudder leading edge to accept the **tailgear wire** and the nylon **tailgear bearing**. **DO NOT GLUE YET!** (The hole is drilled slightly oversize to allow for positioning, and to create a hard epoxy "sleeve" around the wire).

## BUILD THE STABILIZER AND ELEVATORS

- 1. Find the following parts: 3/8" balsa stab front, stab rear and elevators. You'll also need the 3/8" x 5/8" x 11" balsa **stab tip** stock, the 1/8" **elevator ends** that you previously cut, and the 1/8" wire **elevator joiner**.

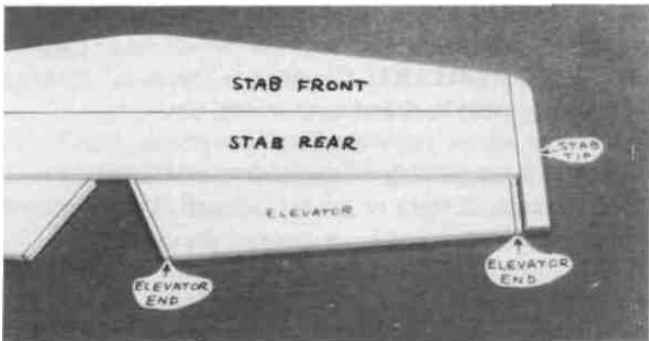

- 2. Glue the **stab front** to the **stab rear**. Then glue on the **stab tips**. Sand the front of the stab tips to blend with the **stab**.

- 3. Glue the elevator ends to the elevators and sand to blend.

- 4. Sand both sides of the stab smooth, then sand the leading edge and lips to a **rounded** shape. (Leave the center portion of the LE **square**). Draw a centerline along the trailing edge of the stab to mark the hinge line.

- 5. Draw a **centerline** all around the edges of the elevators.

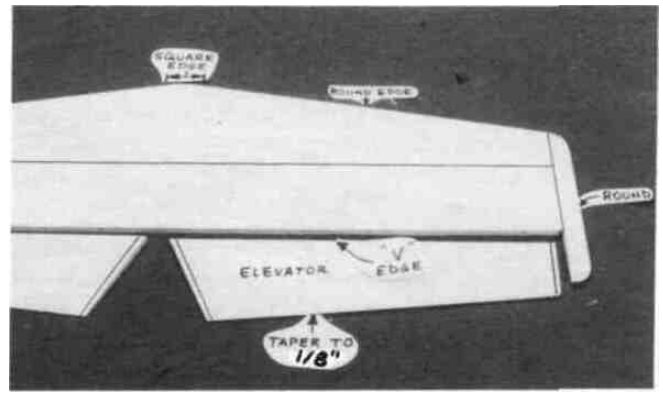

- 6. Sand both sides of the elevators to a **taper** as shown on the plans. The trailing edge should end up approximately 1/8" wide and have a rounded shape (do not sand to a sharp edge). Sand the leading edge to a "**V-shape**" as shown on the plan.

- 7. Temporarily tape the elevators to the stab, providing 1/16" clearance between the elevator end and the stab tip.

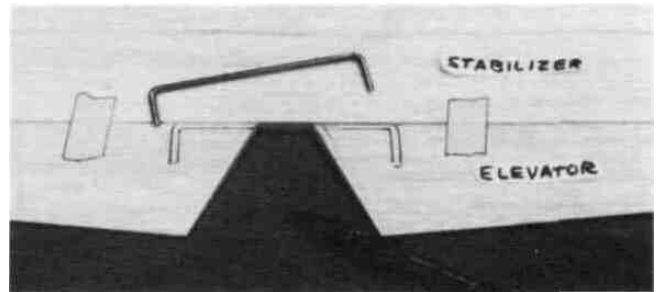

- 8. Lay the 1/8" wire **elevator joiner** in place on the elevators and mark its outline using a fine point felt-tip pen.

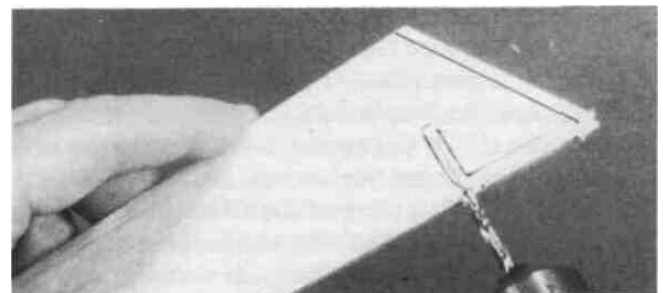

- 9. Accurately drill holes in the elevators for the 1/8" wire joiner. Begin by drilling a 1/16" or 5/64" pilot hole, then drill the final hole to a depth of 7/8" with a 9/64" drill bit. (The hole is drilled slightly oversize to allow for positioning, and to create a hard epoxy "sleeve" around the wire).

- 10. Using an Xacto knife, sharpen the inside of one end of a 1/8" diameter brass tube and use it to cut grooves in the

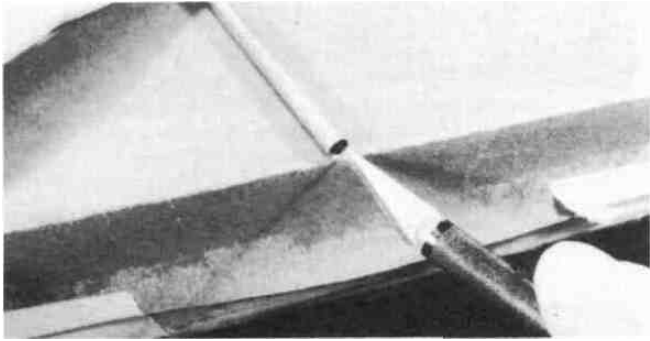

leading edge of the elevators to accept the joiner wire.

- 11. Roughen the joiner wire with coarse sandpaper, then clean the wire thoroughly with alcohol to remove any oily residue.

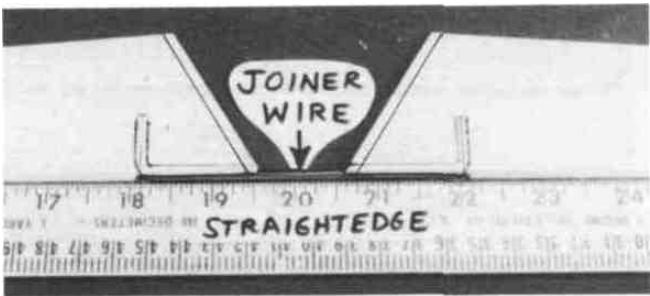

- 12. Trial fit the joiner wire into the elevators, then glue it in using 5-minute or 30-minute epoxy. Work plenty of epoxy into the holes with a toothpick, then lay the elevator leading edges along a straightedge to insure perfect alignment.

## INSTALL THE HINGES (Do not glue)

**NOTE:** One-piece molded polypropylene hinges are supplied in this kit. If you choose to use these hinges or the "pinned"-type hinges, you may cut the hinge slots at this time. However, if you choose to use the one-piece hinges that are paper covered for CA glue installation, you may wait until after covering before cutting the hinge slots.

- 1. Lay the rudder and elevators on the plan and mark the **hinge locations**. Place the rudder against the fin TE and transfer the marks over to the fin. Place the elevators against the stab TE and transfer the marks over to the stab. Note: Heavy duty hinges should be used on the rudder if you are building a taildragger.

**CAUTION!!!:** You must use extreme care when cutting hinge slots with an Xacto knife, to avoid cutting yourself! If the balsa part breaks while you are pushing on the knife, the blade could go into your hand before you know it! A good precaution is to wear leather gloves and always cut away from your hand while performing the following steps.

- 2. Cut the hinge slots **on the accurate centerlines which you previously drew**, using an Xacto knife or a slotting fork and slotting hook. The recommended procedure for cutting hinge slots with an Xacto knife is given below.

A. Begin by carefully cutting a **very shallow slit** in the trailing edge at the hinge location. This first cut is to establish your cut in the right place, so concentrate on staying on the centerline and **don't cut too deep!**

B. Make three or four more cuts in the same line, **going slightly deeper each time**. As you make these additional cuts, work on going straight into the wood. Continue this process while "wiggling" the knife handle back and forth until the blade has reached the proper depth for the hinge.

C. Trial fit the hinge into the slot. If the hinge is difficult to push in, re-insert the knife and move it back and forth in the slot a few times to enlarge the slot

- 3. **IMPORTANT!** Condition or "break-in" the hinges by folding them back and forth several times.

- 4. Insert the hinges into the slots and trial fit the rudder and elevators in place on the fin and stab. **Do not glue the hinges until after you have covered the model.**

## WING

**NOTE:** The following instructions explain how to build the wing on a flat surface, directly on the plans. An alternate method is to use a Great Planes Wing Jig (available from your local hobby dealer). Many expert modelers prefer to use a wing jig for high performance airplanes, as it helps to insure a straight, warp-free wing, especially if you do not have a workbench or building board that is perfectly flat. If you choose to use the Wing Jig, please read the instructions that are included with the jig before beginning.

## BUILD THE WING PANELS

**NOTE:** It will be helpful to build the wing on a piece of "Celotex" or other semi-soft (and flat) surface, into which you may easily stick pins to firmly hold down the wing parts while building, to avoid warps.

- 1. Tape the plan to your flat work surface, and cover the wing drawing with waxed paper (so you won't glue the wing to the plan!). **NOTE;** If your work space is limited, you may cut the left and right wing half drawings apart.
- 2. The shaped and notched wing **leading edges (LE)** and **trailing edges (TE)** are fastened together by thin strips of balsa. Separate them by folding until the balsa breaks. Sand away the excess balsa that remains along the edges after breaking them apart, using a T-bar with 100-grit sandpaper.
- 3. Before using the 1/4" x 1/2" x 30" hard balsa **spars**, examine them carefully for possible imperfections. Look for knots, soft spots, diagonal grain and any other imperfections. If possible, position each spar so the imperfections (if any) are on the outer half of the wing panel (toward the tip), where they will be least affected by high stress. If the spars are warped slightly, try to "balance them out" by installing the warped spars in opposite directions (see sketch).

TWO WARPED SPARS INSTALLED  
THIS WAY WILL RESULT IN A  
STRAIGHT WING



TWO WARPED SPARS INSTALLED  
THIS WAY WILL RESULT IN A  
WARPED WING



- 4. Find the four 1/8" x 1/2" x 14-1/2" balsa **spar doublers**. Sand one end of each spar doubler to a taper as shown in the "Wing Spar Detail" on the plan. Glue the spar doublers to the spars, and sand off any excess glue.

- 5. Carefully punch out all the die-cut 3/32" balsa **wing ribs**. Sand the edges **slightly** to remove any die-cutting irregularities.

**NOTE:** If you will be installing a retractable landing gear, disregard Steps 6 and 7.

- 6. Note that the wing plan shows two alternate locations for the main landing gear blocks. Note also that Ribs W-2, W-3 and W-4 have **partial cutouts** for each of the two locations. If you are building your plane as a **taildragger**, cut out the **front** notches in these ribs. If you are building your plane with a **tricycle gear**, cut out the **rear** notches. (If you will be installing retracts, do not cut out any of the notches).
- 7. Glue the die-cut 1/16" ply **landing gear doublers** to ribs W-2, W-3 and W-4. Be sure to glue them to the correct side of the ribs, as shown on the plan (make a **right** and a **left** set). Sand the doublers even with the edge of the ribs.
- 8. Prepare the **leading edge sheeting** as follows: Edge glue the 3/32" x 1" x 13" balsa sheets to the 3/32" x 3" x 30" balsa sheets as shown here ...

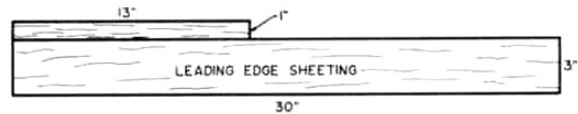

Now measure and mark the balsa sheeting (see sketch below), then cut the angle in the sheeting, cutting along a metal straightedge for accuracy.

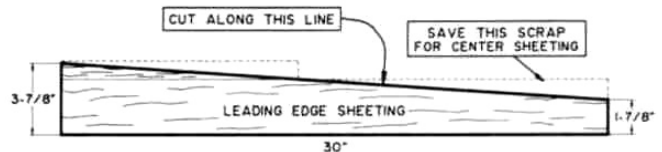

**NOTE:** Follow steps 9 through 34 to build the **RIGHT** wing panel, then repeat these steps to build the **LEFT** wing panel

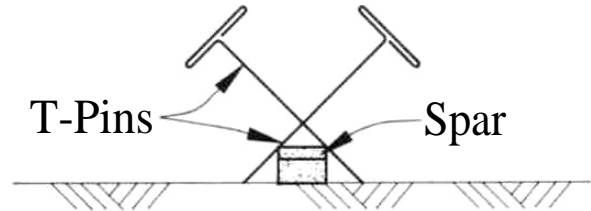

- 9. Pin one of the spars to the plan with the spar doubler **up** and toward the root **NOTE:** The spars are cut slightly too long. Center the spar on the plan so an equal amount protrudes on both ends.

□□ 10. Place the ribs on the spar in their approximate position, but do not glue. **NOTE:** Make sure ribs W-2, W-3 and W-4 are installed with the LG notches **down**, and W-1 is installed with the servo opening pointing **up**.

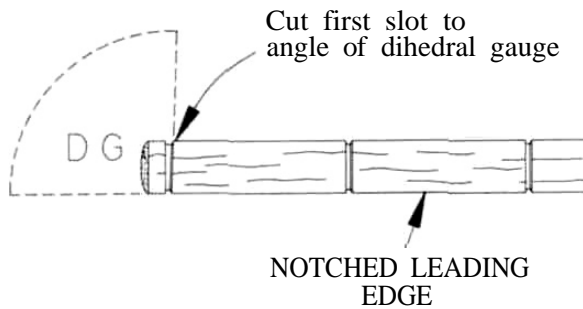

□□ 11. Examine the shaped, notched leading and trailing edges. Notice that the notches at one end of each LE and TE are only 2-5/8" apart. These are the notches for W-1 and W-2. Also notice that all notches in the LE and TE are **vertical**; however, rib W-1 will be installed at a slight angle using the Dihedral Gauge. Therefore, you should now modify the notch for W-1 by cutting it to the angle of the rib. You may determine the approximate angle of the cut by holding the Dihedral Gauge (DG) against the LE as shown above.

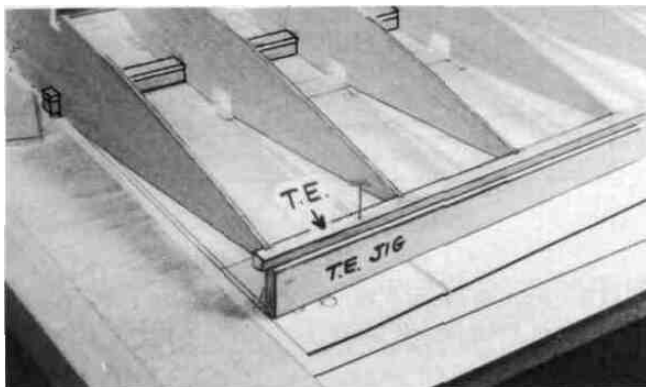

□□ 12. Insert the rear ends of the ribs into the notches in the TE, then block up the TE with the 1/4" balsa TE Jig supplied. **NOTE: The narrow end of the TE jig is at rib W-II.** Pin the jig to the building surface.

□□ 13. Pin the TE to the TE Jig, making sure the ribs line up with the plan.

□□ 14. Glue ribs W-2 through W-11 to the TE. (Apply glue sparingly, to avoid gluing the TE to the TE Jig).

□□ 15. Insert the front ends of the ribs into the notches in the LE. **NOTE:** Position the LE as shown at the top of the next column.

## CENTER L.E. VERTICALLY ON FRONT OF RIBS

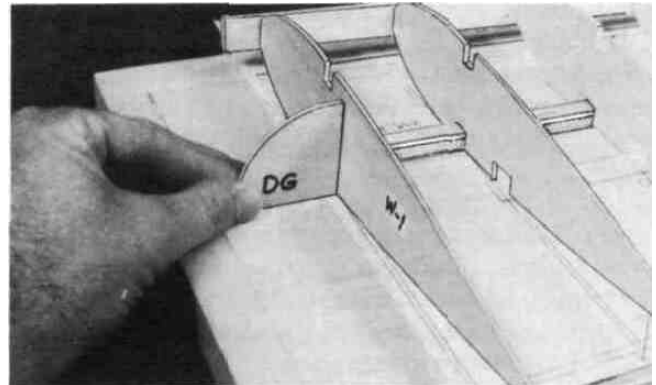
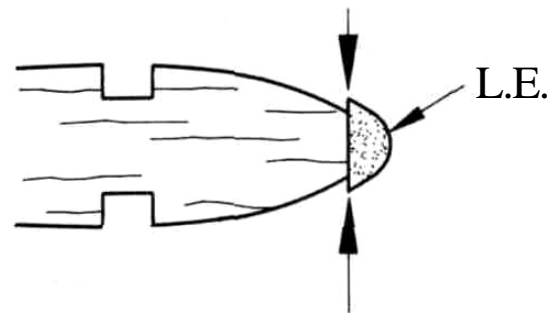

□□ 16. Make sure the ribs are fully down on the plan and all ribs are inserted into the LE notches. Angle rib W-1 slightly using the dihedral gauge (DG). Glue W-1 to the TE, LE and bottom spar. Glue all other ribs to the LE and bottom spar.

□□ 17. Glue the top spar in place, making sure you do not change the angle of W-1.



□□ 18. Glue the pre-cut 3/32" balsa vertical grain **shear webs** to the rear edge of the spars in all rib bays **except between ribs W-1 and W-2**. **NOTE:** You may wish to trial fit, mark, and trim each web before gluing in. **NOTE:** The webs must be securely glued to the spars, but it is **not** necessary to glue the webs to the ribs.

□□ 19. You will now make a "pocket" for the 1/16" ply dihedral brace by installing a 3/32" balsa web **1/16"** behind the spars. Sand one of the 3/32" x 2-3/16" x 2-1/2" balsa **horizontal grain** webs for a good fit between W-1 and W-2. (See photo at top of next page.)

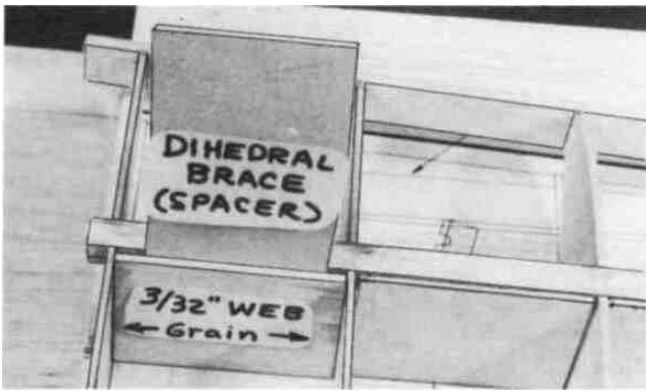

Using the 1/16" ply **dihedral brace** as a temporary spacer, glue the 3/32" web to W-1 and W-2.

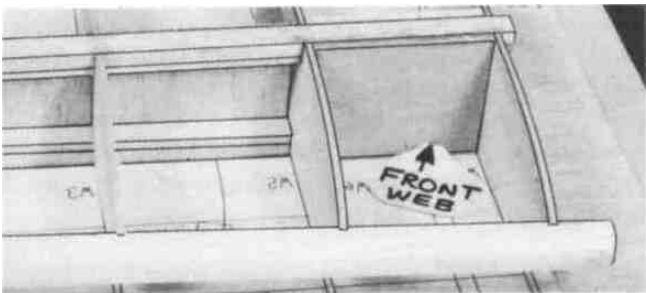

□□ 20. Glue the die-cut 1/8" ply **front web** to the front edge of the spars between ribs W-1 and W-2.

**NOTE:** In the next steps, maintain straightness by keeping the wing down on the flat surface and on the TE Jig.



□□ 21. Lightly sand the lops of the ribs to blend with the notched trailing edge; then glue one of the 3/32" x 1-3/4" x 30" balsa trailing edge sheets in place. **NOTE:** The edge of the TE sheet may not be exactly straight, but just position the sheet so it slightly overlaps the TE, and any overlap can be sanded off later.

□□ 22. Before applying the leading edge sheeting in the next step, use your T-bar to lightly sand off the edges of the shear webs and smoothly blend the ribs to the spar.

□□ 23. Prepare the 3/32" balsa **leading edge sheeting** by sanding the front edge to a slight bevel so it will fit snugly against the back of the leading edge.

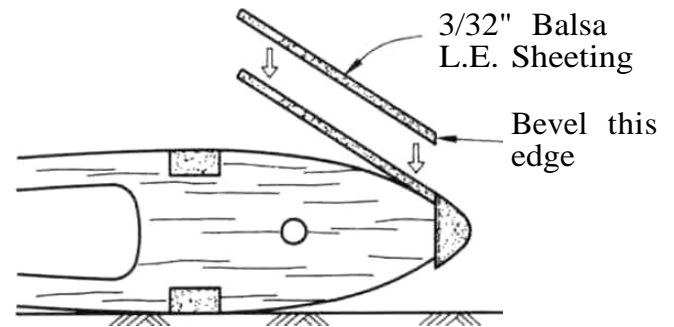

**NOTE:** It will be helpful to have the following items handy for the next step... thin CA, thick CA, a wet cloth, masking tape and T-pins. Read through the following step and go through a "dry run" before actually gluing.

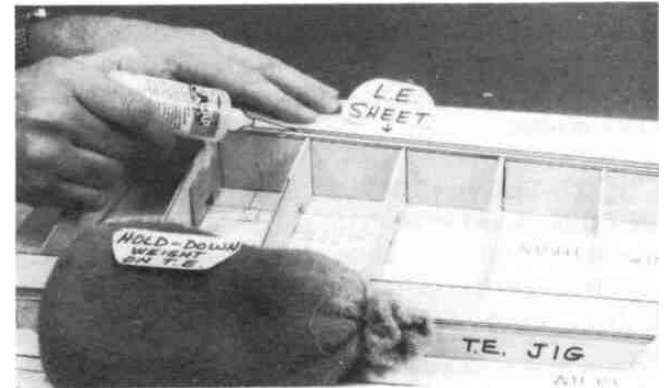

□□ 24. Position the leading edge sheeting at the rear edge of the notched LE so there is an equal amount protruding on both ends of the wing. Using thin CA, glue the front (beveled) edge of the leading edge sheeting to the back edge of the leading edge. Now wet the top surface of the sheeting so it will bend easier. Apply thick CA glue to the top edge of the ribs and to the front half of the spar, then immediately bend the sheeting down onto the ribs and spar. Hold the sheeting down with masking tape, pins and your hands until the glue has set.

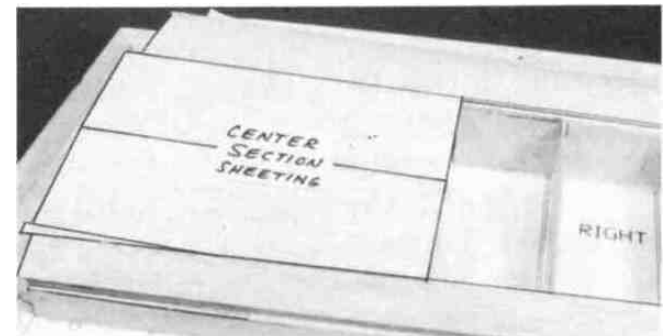

□□ 25. Using the 3/32" x 3" x 8-13/16" balsa sheets, glue the top center section sheeting in place as shown on the plan. (Use the scraps trimmed from the LE sheeting for the aft pieces).

**NOTE:** If you are installing retracts, disregard steps 26 through 29.

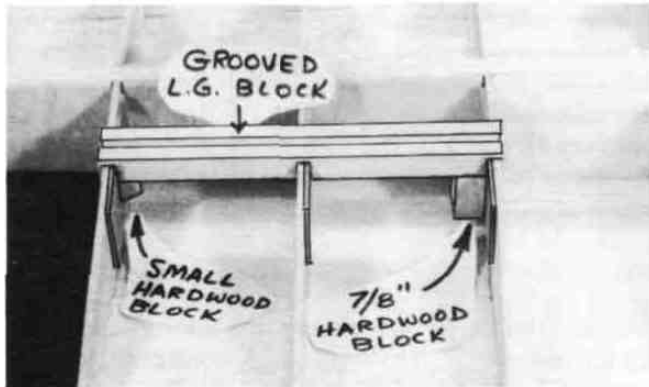

26. Remove the wing from the building board and trial fit the long grooved hardwood **LG block** into the notches in ribs W-2, W-3 and W-4 (see the landing gear detail drawing on the wing plan for proper positioning). File the notches if necessary for a good fit. Now use epoxy to securely glue the block in place.

27. Epoxy the 7/16" x 5/8" x 7/8" **hardwood block** to the LG block and to the 1/16" ply doubler on rib W-2, as shown on the plan and in the photo, then epoxy the **small hardwood block** to the other end of the LG block and to the 1/16" ply doubler on rib W-4.

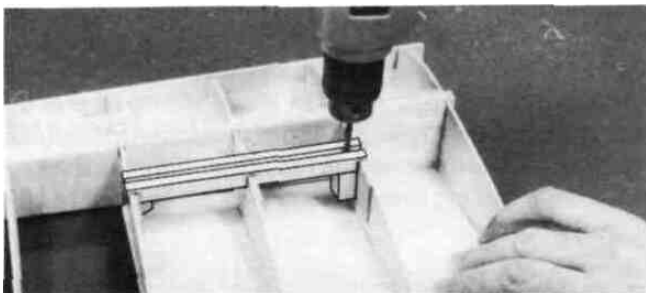

28. Drill a 5/32" hole down through the grooved LG block and the 7/8" block. Line up the drill so you are drilling straight down through the middle of the 7/8" block.

29. Trial fit the 5/32" diameter **main landing gear wire** into the landing gear block at this time. Cut or file the groove and hole in the landing gear block as necessary for a good fit

30. Using a razor saw and a sanding block, carefully cut off and sand all excess sheeting, spars, LE and TE even with W-I and W-II.

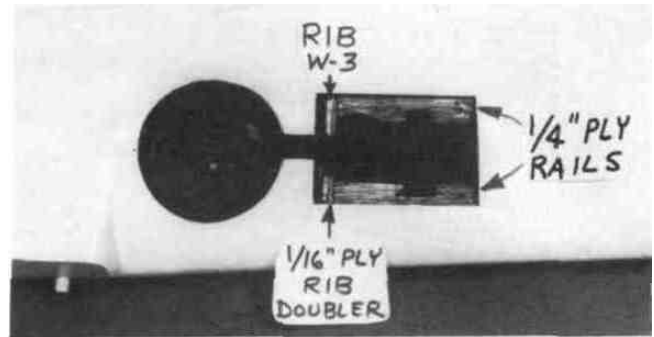

*Photo of finished wing with retract mechanism removed.*

**NOTE:** If you will be installing retracts, now is the time to glue in the 1/16" ply die-cut rib doublers to the front portion of ribs W-3 and W-4. (Make sure the front rib doublers are on the outboard side of W-3 and the inboard side of W-4). This is also the time to install the 1/4" x 13/16" x 2-11/16" ply retract mounting rails on the bottom of the wing, in the location shown on the plan. Lock and strengthen the joints between the 1/4" ply rails and the 1/16" ply rib doublers by gluing 1/4" balsa triangle stock to these joints. You should also now do some planning and trial fitting of the retract and pushrod, customizing the installation as necessary [to] accommodate your retracts. **Installing retracts requires careful planning and a lot of trial fitting;** therefore, you should take the time now to plan out your installation.

31. With the wing upside down, again use the **TE jig** to support the TE. Then install the bottom TE sheeting, LE sheeting and Center Section sheeting, cutting and fitting the sheeting around the LG block as necessary. **IMPORTANT NOTE:** To insure a straight wing, you must pin or weight the TE securely down on the TE jig while the bottom sheeting is glued in place!

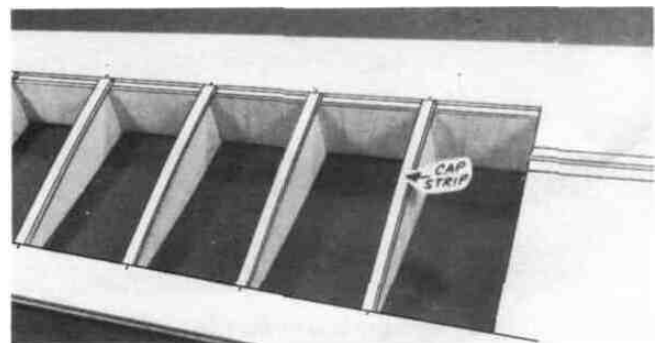

32. From the 3/32" x 3/8" x 30" balsa sticks, cut and glue **cap strips** to all exposed ribs, top and bottom. **HINT:** For easier positioning of the cap strips, first mark the location of each rib on the LE and TE sheeting.

33. Trim the sheeting flush with ribs W-I and W-II and sand the entire wing panel smooth. Sand the leading edge to smoothly blend with the LE sheeting (see the note on the following page).

**IMPORTANT:** The shape of the leading edge will affect the way this airplane performs snap rolls and spins. A blunt, rounded leading edge will "soften" the stall, making the plane very docile when flying slowly, enabling it to flare nose-high for very slow landings; however, this may cause the plane to be a little sluggish when trying to enter a snap roll or spin. A sharper leading edge will help the plane enter snap roll and spin maneuvers more crisply, while sacrificing only a little of the low speed stability. The leading edge has been approximately pre-shaped to the sharper cross-section, so try to maintain the same LE radius when sanding to blend with the LE sheeting. To **avoid tip stalls**, **make sure the leading edges of both wing panels have the same shape.**

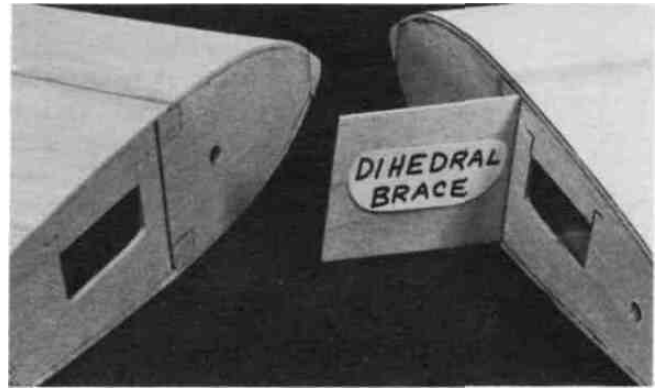

**NOTE: 30-minute epoxy is strongly recommended for the wing joining process.**

- 3. Mix up a batch of **30-minute** epoxy and push some into the dihedral brace slots. Smear epoxy on the spar ends, and on both sides of the 1/16" ply dihedral brace. Slide the dihedral brace in place, push the wing panels together and **immediately proceed to the next step.**

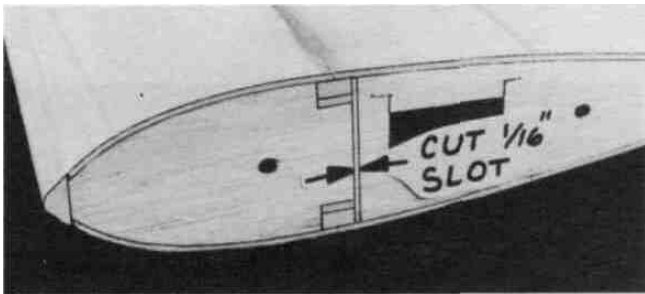

- 34. Mark and cut out a 1/16" slot in W-1 just behind the spars, for the dihedral brace.

- 35. Now go back and repeat Steps 9 through 34 to build the left wing panel.

## JOIN THE WING PANELS

**NOTE:** Read steps 1 through 4, then make a "dry run" through these steps before actually proceeding.

- 1. Lay a piece of waxed paper down and place the two wing panels, right side up, so that the W-1 ribs are together. Using the 1-1/8" x 1-9/16" x 9-3/4" balsa wing tip blocks, block up both wing tips **1-1/8-inch**. Sand the wing panels at the center so they will fit together without a gap.

- 2. Trial fit the 1/16" ply **dihedral brace** to make sure it will readily slide into place. (The photo for this step is at the top of the next column).

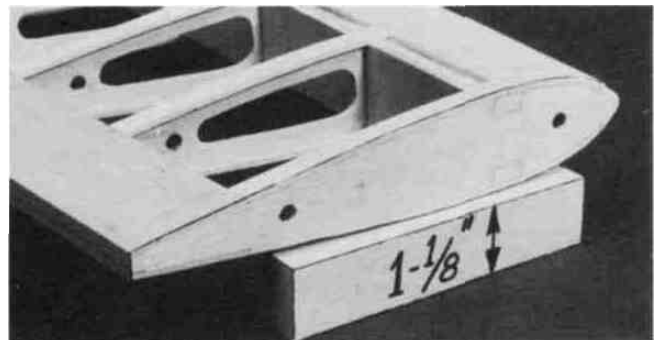

- 4. With the wing tips blocked up 1-1/8 inch, carefully align the LE and TE of both wing panels at the center and, while holding them in correct alignment, apply thin CA glue to "lock" the panels together. **Do not apply CA glue to any area that is already coated with epoxy.** Allow the epoxy to fully harden before disturbing the wing.

- 5. Sand the wing joint smooth all around.

## INSTALL AILERON TORQUE RODS

- 1. Roughen the short end of the **aileron torque rods** with 100-grit sandpaper, and file the same end to a wedge shape. (See sketch on next page).

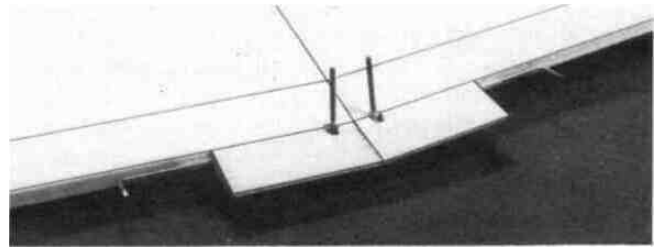
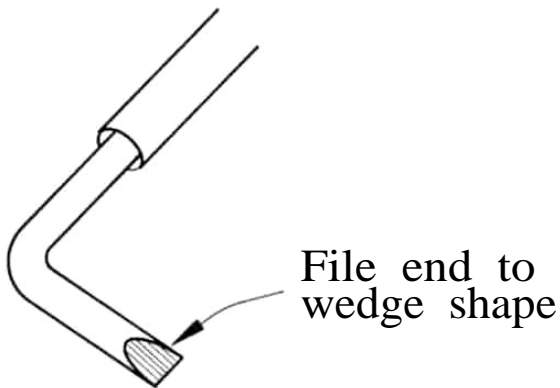

pieces in place with epoxy. **HINT:** Use masking tape to hold these pieces to the wing TE, to aid in correct positioning.

- 2. Roughen the surface of the plastic bearing tubes with 100-grit sandpaper.
- 3. Clean the torque rods and bearing tubes with alcohol.
- 4. Find the two grooved, tapered balsa **center trailing edge** pieces. Lay them on the plan, mark and cut them off to match the plan for length and angle at the centerline.

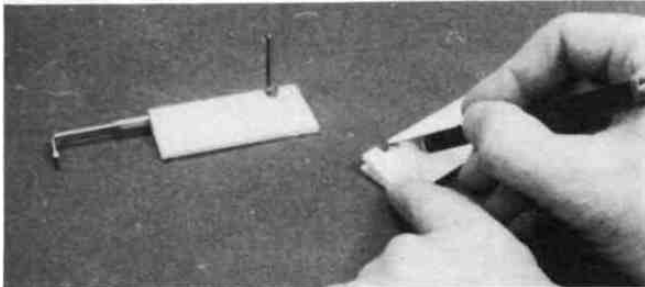

- 5. Trial fit the torque rods into the center TE pieces. Determine from the plan where to cut the clearance notches, which will permit the torque rod horns to travel freely. Also cut small clearance notches in the wing TE. Note: **The torque rod horns must exit the TOP of the wing!**
- 6. Slide the plastic bearings toward the threaded end of the torque rods, then use a toothpick to apply a small amount of petroleum jelly to the ends of the plastic tubes (to help prevent glue from getting inside and locking up the torque rods).
- 7. Use 5-minute epoxy or thick CA to glue the plastic bearing tubes into the grooves in the center TE pieces. Wipe off any excess glue and allow it to harden.
- 8. Trial fit the trailing edge / torque rod assemblies onto the wing trailing edge. Sand the center trailing edge pieces slightly where they join, for a good fit. Glue these

## SAND "FLATS" ON LE AND TE

- 1. Study the wing plan near the wing centerline. Note that the center portion of the LE and TE must be sanded flat.

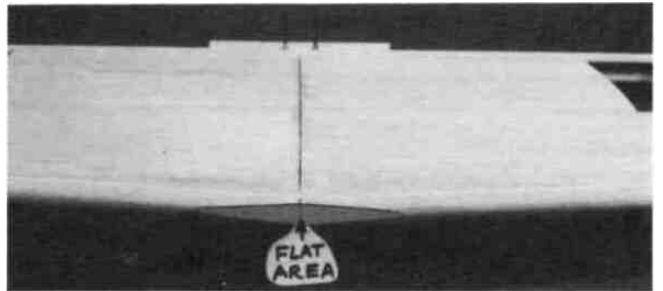

- 2. Sand approximately 5/32" into the LE at the centerline, and approximately 3/32" into the TE at the centerline. (The flats will end up approximately 4-1/2" wide at the LE, and 2" wide at the TE).

## FIBERGLASS THE CENTER SECTION

**NOTE; Because of the high stresses in the center of this wing, Fiberglass reinforcement is REQUIRED. Please do not omit this important section!**

**NOTE:** If you have previous experience with applying fiberglass, feel free to use your favorite method, providing that it results in a strong bond between the glass cloth and the wood. If this is your first time, we offer the following suggested method, which is the fastest and easiest we have seen.

- 1. Make **location marks** for the fiberglass reinforcement cloth, 2" each way from the wing centerline.

- 2. **Trial fit** the 4" wide fiberglass cloth in place. You can use a scissors or a paper punch to cut holes in the glass cloth for the aileron torque rod horns.
- 3. Wrap small pieces of masking tape around the threaded portion of the aileron torque rods to protect them from the spray adhesive in the next step.
- 4. Spray a very light mist of 3M "77" Spray Adhesive on the center section in the area to be glassed. Hold the spray can at least 12" away from the surface when doing this to avoid a heavy buildup. The purpose of this is only to give the wood a little "tackiness". If you apply too much spray it could result in a poor glue bond. Allow the spray to dry for 5 minutes before proceeding to Step 5.

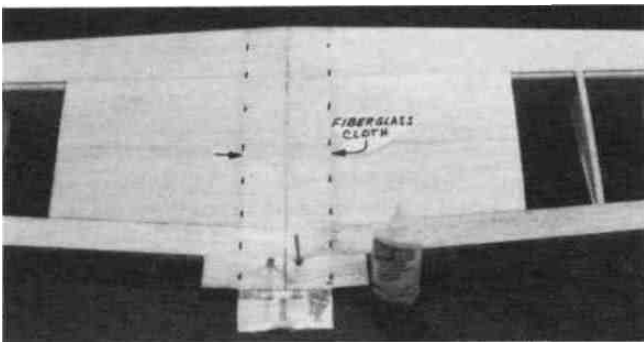

- 5. Beginning at the trailing edge, lay the glass tape in place on the wing. Gently press the cloth in place, working out all the wrinkles. The "77" spray adhesive should hold the cloth down to the surface, but will permit you to lift and reposition the cloth if you make a mistake. Keep working forward along the top of the wing, around the leading edge, and along the bottom of the wing, ending at the trailing edge. Do not attempt to wrap the glass cloth around the trailing edge.
- 6. Working outdoors or in a **very well-ventilated area** apply **thin** CA glue to the glass cloth. Begin by running a bead of glue down the center of the glass cloth strip, then continue applying the glue in lines until all the cloth has been secured. Run the thin CA out 1/4" beyond the edges of the glass cloth to help protect the balsa sheeting when sanding later. **WARNING: This operation produces a larger than normal quantity of CA fumes, so adequate ventilation is a must!**
- 7. Inspect the surface of the glass cloth. If any areas are not glued down, apply a couple more drops of CA glue and press down with a piece of waxed paper until the glue sets.
- 8. To make sure the glass cloth is fully "wetted out" and bonded to the balsa, you may apply more thin CA, a few drops at a time, and spread it out with a piece of waxed paper.

- 9. After the glue has set, trim the excess cloth at the trailing edge with a sharp Xacto knife followed by a sanding block.
- 10. Carefully sand the **edges** of the glass cloth with a T-bar sander with 80 or 100-grit sandpaper. Also, **lightly** sand the surface of the glass cloth with a piece of sandpaper held in your fingers to remove any rough spots. **WARNING: When sanding fiberglass, wear a dust mask to avoid breathing airborne glass fibers.**

## INSTALL WING TIPS

**NOTE:** The wing tips will be carved from the 1-1/8" x 1-9/16" x 9-3/4" balsa blocks.

- 1. Draw a centerline on the ends of the wing and on the wing tip blocks.

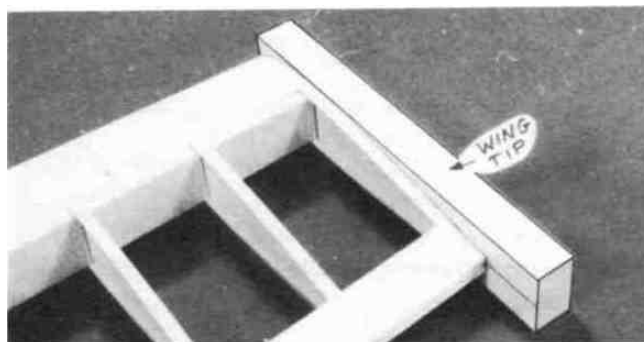

- 2. Securely glue a wing tip block to the left end of the wing, and **tack glue** a wing tip block to the right end of the wing, lining up the centerlines you previously drew. You will **later** break only the right lip loose and hollow it out.

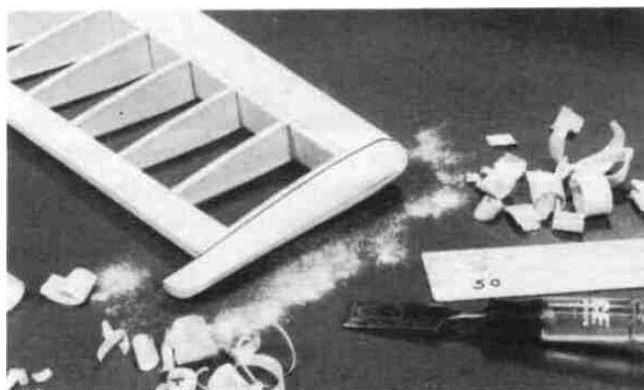

- 3. Cut, carve and sand the wing tips to the appropriate shape as shown on the plan. **HINT;** Use 50-grit sandpaper and a sharp wood chisel or razor plane to speed up this operation. **NOTE:** Leave the tips oversize in the area of the ailerons, for now.

- 4. Cut the **right** wing tip loose from the wing and use a Dremel Moto Tool to hollow out the wing tip. (This will help to compensate for the weight of the engine head and muffler).
- 5. Now securely glue the right wing tip in place.

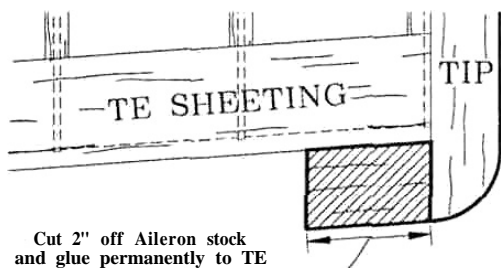

- 6. Cut 2" off one end of the tapered ailerons and glue the 2" pieces permanently to the trailing edge as shown in the sketch. This moves the aileron away from the turbulence caused by the tip vortex. Make sure you carefully line up this piece with the top and bottom surfaces of the wing.

## INSTALL AILERONS

**NOTE:** Do not glue the aileron hinges until after your model has been covered.

- 1. Draw an accurate **centerline** along the LE of the tapered balsa **aileron** and the wing TE,
- 2. Check the length of your ailerons against the actual aileron openings and **trim** the ailerons as necessary. You should provide approximately 1/16" gap at each end of the ailerons.

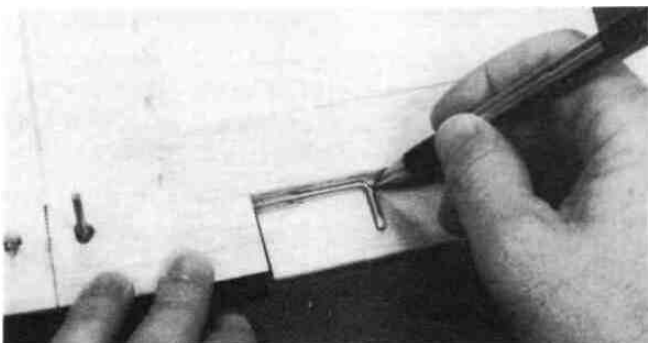

- 3. Lay the ailerons in place in the openings, with the torque rods resting on top of the ailerons. **Mark the torque rod locations on the top of the ailerons.**

- 4. Drill a 7/64" hole in the ailerons at the torque rod locations, starting at the leading edge centerline and drilling **straight** in to the proper depth. (The hole is drilled slightly oversized to allow for positioning, and to create a hard epoxy "sleeve" around the wire).

- 5. Use the sharpened 1/8" diameter brass tube to **cut a groove in the leading edge of the ailerons** to accept the torque rods. Cut these grooves a little larger at the beginning,

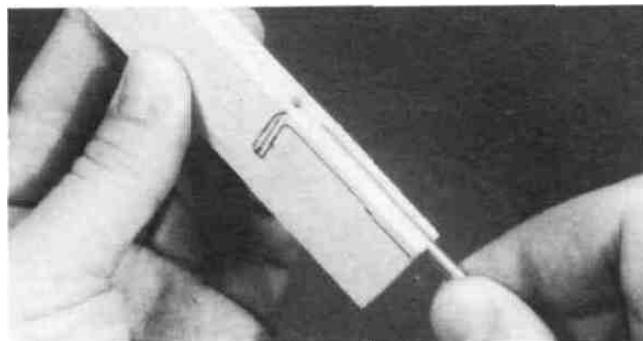

to make room for the torque rod bearings. Trial fit the ailerons onto the torque rods and cut or file as necessary until they fit.

- 6. Lay the ailerons on the plan and mark the **hinge locations** on the ailerons. Use **two** hinges near the tips. Place the ailerons against the wing TE and transfer the marks over to the wing.

- 7. Cut the hinge slots in the ailerons and wing TE using an Xacto knife or hinge slotting tool.

- 8. **IMPORTANT!** Condition or "break-in" the hinges by folding them back and forth several times,

- 9. Sand the leading edge of the ailerons to the same **"V"-shape** as shown on the wing rib detail drawing.

- 10. Insert the hinges into the slots and trial fit the ailerons in place on the wing. **Do not glue the hinges until after you have covered the wing.**

**There should be no hinge gap!**

- 11. Now is a good time to finish the wing tips. Tape the ailerons on in the neutral position, and sand the wing tips to blend with the ailerons.

## INSTALL WING DOWELS

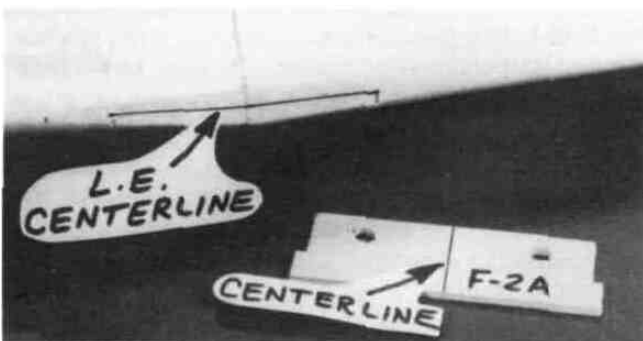

- 1. Mark a horizontal centerline on the flat which you sanded on the wing LE. Also mark a vertical centerline on the die-cut 1/8" ply former **F-2A** (the Wing Dowel Plate).

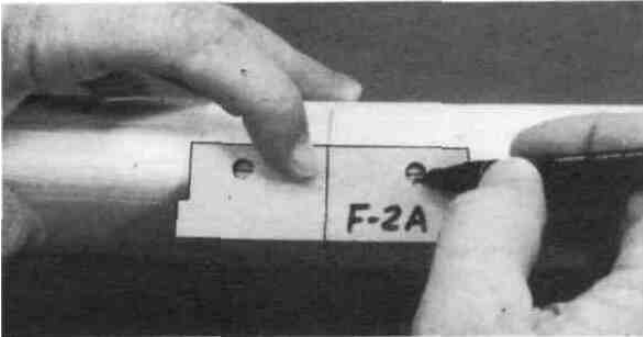

2. Holding the die-cut 1/8" balsa **F-2A** on the leading edge, in the exact center of the wing, mark the dowel locations through the dowel plate holes.

3. Remove F-2A and double check to make sure the dowel locations are both the same distance from the wing center joint

4. It is important that you now drill the dowel holes **accurately!** To insure accurately positioned holes, begin by drilling small (1/8") holes in the center of the marked locations. Then gradually increase drill bit sizes until you have finally drilled the holes to 1/4" **diameter**. The final holes you drill must extend 3-3/4" into the wing to penetrate the front webs. **NOTE:** Try to drill **straight in**.

5. Sand **one end** of each wing dowel to a rounded or pointed shape. This is the end that will be inserted. Do not sand the other end at this time.

6. Trial fit the dowels into the dowel holes, and trial fit the dowel plate over the dowels. If the dowels fit too tightly, you may enlarge the holes slightly using a round file, or you may sand the dowels down slightly. **Do not** glue the dowels **in place** at this time.

### INSTALL WING BOLT PLATE

1. Mark a centerline on the die-cut 1/16" x 3-15/32" x 1-5/8" ply **wing bolt plate**.

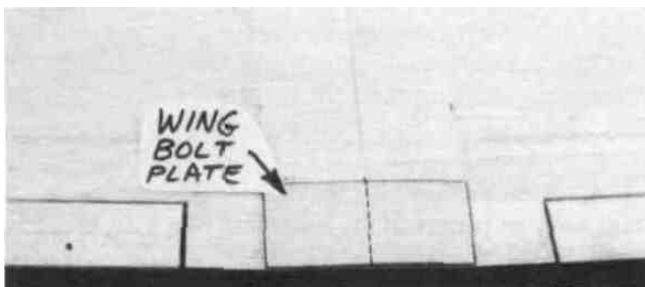

2. Position the wing bolt plate on the **bottom** of the wing, and line it up with the wing TE and centerline. Glue it in place.

3. Sand the wing bolt plate flush with the wing TE.

### FILL LANDING GEAR SLOTS

1. Temporarily install the main LG wires.

2. Check the plan for the location of the nylon landing gear straps and temporarily install them, using #2x3/8" sheet metal screws.



NYLON LANDING  
GEAR STRAP



#2X3/8" SHEET  
METAL SCREW

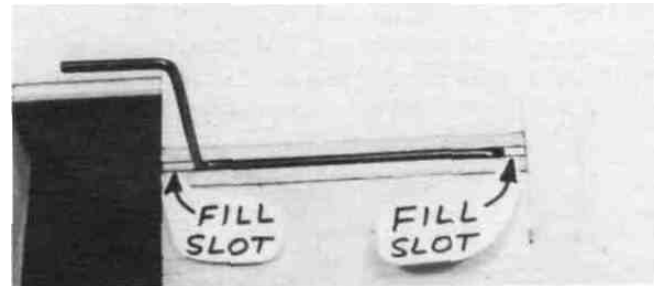

notched LG blocks and sand flush with the surface of the wing. This will aid in covering later.

### INSTALL RETRACTS (OPTIONAL)

**NOTE:** Hardware for retract installation is not included in the kit

1. Study the retract drawings on the plan, and the I installation instructions provided with your retracts, and plan your retract installation before proceeding,

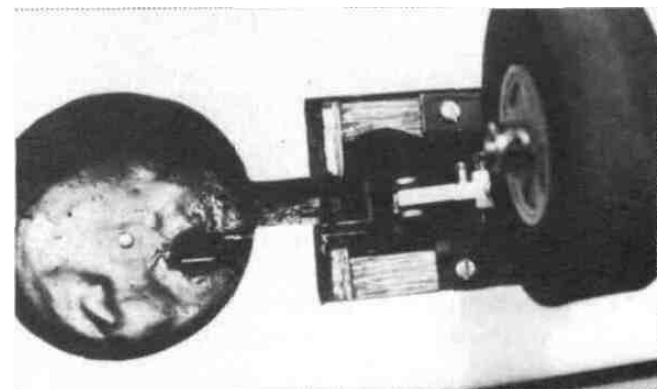

*Photo shows finished wing with retract installed.*

2. Cut an opening in the bottom LE sheeting for the

retract mechanism. Cut a clearance slot in rib W-3 for the LG wire. Cut an opening in the bottom LE sheet and in rib W-2 for the wheel well.

3. Enclose the wheel well by running vertical grain 1/16" balsa between the bottom and top sheeting; or you may make the wheel well from an appropriately-sized styrofoam cup.

of the spars) for your retract servo, and bend and fit a pushrod to run between the servo and the retract mechanism. Run the pushrod just under the top LE sheeting until it passes over the wheel well, then make two 90-degree bends and connect it to the retract mechanism.

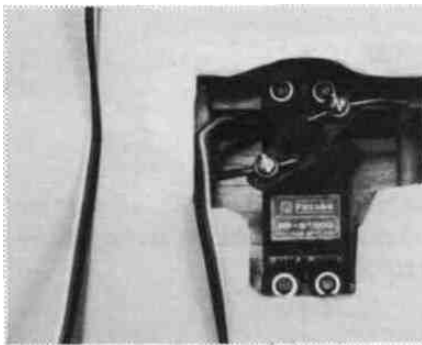

5. Temporarily mount your retract servo and trial fit all retract components. Test the operation of your retracts making sure they operate freely and reliably. Also make sure they "lock" in both the up and down positions.

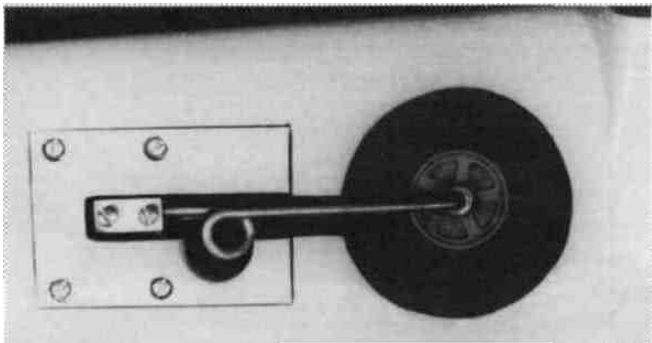

*Photo shows finished wing with retract installed.*

6. Blend the bottom sheeting as neatly as possible around the retracts.

7. Use polyester resin or 30-minute epoxy thinned with alcohol to fuelproof the entire retract well area.

## FUSELAGE ASSEMBLY

### PREPARE FUSE SIDES

1. Lay one of the shaped 3/16" balsa **fuselage sides** in place on the fuselage plan side view. Carefully position the fuse side so the front edge lines up with **the front** of F-1 on the plan. Tape or pin the fuse side so it can't move. **NOTE:** The fuse side may be a little longer at the rear than indicated by the plan. This is as it should be.

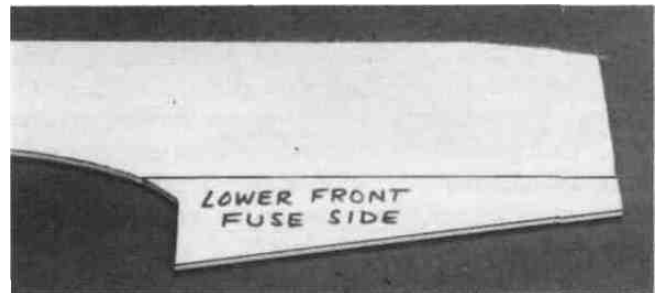

2. Carefully position the die-cut 3/16" balsa **lower front fuse side** so the rear edge lines up with the front of the wing saddle opening on the plan (the rear edge of F-2A). You may have to lightly sand the top edge of the die-cut 3/16" balsa for a good fit against the bottom edge of the fuse side. Edge glue the lower front fuse side to the fuse side. **NOTE:** Use waxed paper under the balsa to avoid gluing to the plan.

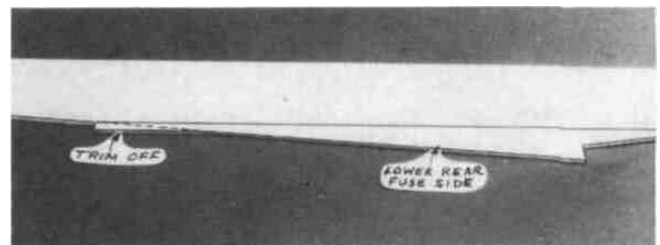

3. Carefully position the die-cut 3/16" balsa **lower rear fuse side** so the vertical front edge lines up with the rear of the wing saddle opening on the plan (the front edge of F-4). Edge glue the lower rear fuse side to the fuse side.

4. Trim and sand off the die-cut "bumps" from the front and rear portion of the lower rear fuse side, blending with the upper fuse side.

5. Sand the fuse side smooth on both sides using a T-bar and 100-grit sandpaper, then repeat the above steps to make the other fuse side.

6. Find the two die-cut 1/8" ply **fuselage doublers** and the four die-cut 1/8" ply **firewall spacers**. Note that the spacers are marked "2 L", "2 R", "4 L", and "4 R".

Use the #2 firewall spacers if you will be installing a 2-cycle engine such as the OS Max 61 SF.

Use the #4 firewall spacers if you will be installing a small 4-cycle engine, such as the OS FS 70 Surpass.

If you will be installing a larger (longer) 4-cycle engine, such as the OS FS 91 Surpass, do not use **any** firewall spacer on the right side, and use the 1/8" x 1/8" x 3-5/8" hardwood stick as a firewall spacer on the **left** side.

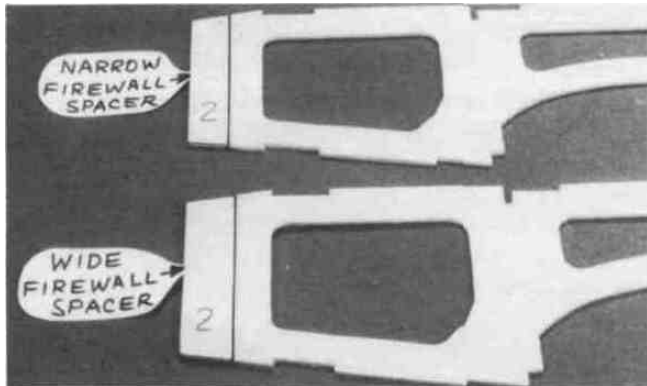

7. Edge glue the appropriate firewall spacers to the front edge of the fuselage doublers. Note that the spacers are not the same size. They will automatically set the engine at the required 2-degrees right **thrust**.

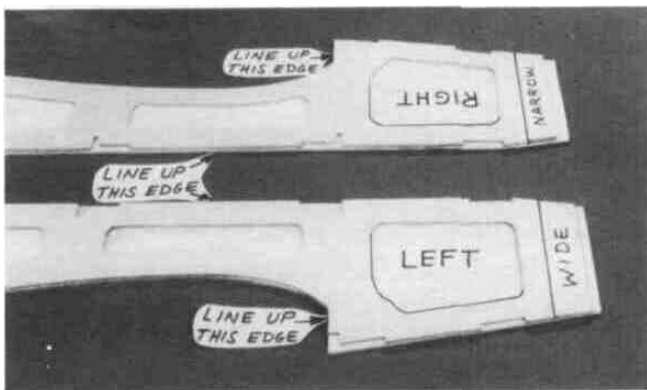

8. Carefully position the fuselage doublers on the fuse sides, **making a RIGHT and a LEFT side**. The doubler with the smaller firewall spacer goes on the right fuselage side ..

**PLAN IT OUT!** It is important that the fuse doubler and fuse side line up along the **top edge** and the **front of the wing opening**. While holding in position, apply thin CA glue around all the notches and lightening holes, then around the edges. Make sure you apply sufficient glue so it flows under the doubler to produce a strong bond. **NOTE:** The narrow and wide firewall spacers will automatically position the firewall to result in 2-degrees of **right engine thrust**.

9. Glue the tapered balsa **tail filler** to the aft end of one of the fuse sides and sand it even with the top and bottom edges.

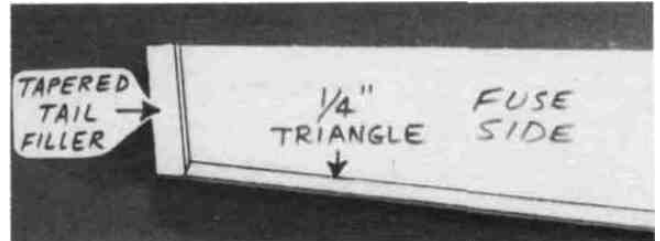

10. From the 1/4" balsa triangle, cut pieces to fit between the tail filler and the **rear** of F-4, along the bottom inside of both fuse sides. Glue in place.

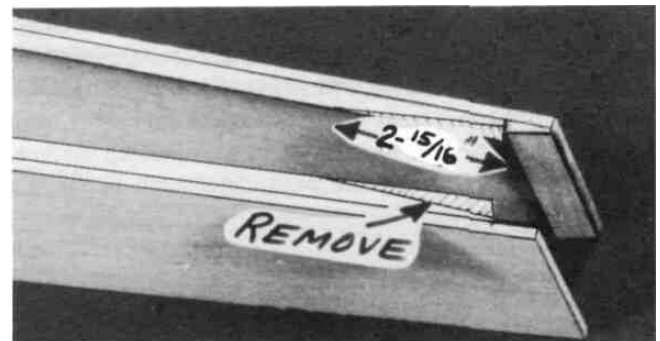

11. Sand the aft ends of the balsa triangle to a taper, which will permit the fuse sides to be pulled together at the aft end. **NOTE:** The taper shown in the photo is approximate and may have to be modified during assembly.

## ASSEMBLE LOWER FUSELAGE

1. Tape the fuselage plan to your workbench and cover the **Fuse Bottom View** with waxed paper.

**NOTE:** The fuselage is assembled **upside down**.

2. Pin or tack glue (using 3M "77" Spray Adhesive) the 1/8" die-cut balsa stab base accurately in position on the plan. Align the front edge of the stab base with the line on the plan.

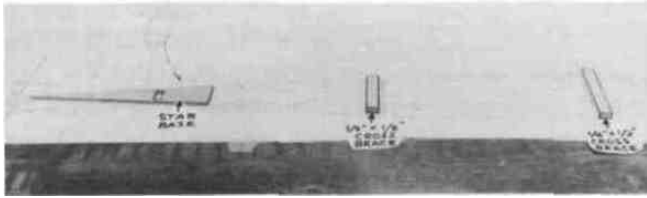

3. Accurately position the two pre-cut 1/4" x 1/2" balsa **cross-braces** on the plan, and pin them in place behind F-4 and F-5. **Note:** The front cross-brace (at F-4) extends only out to the doublers.

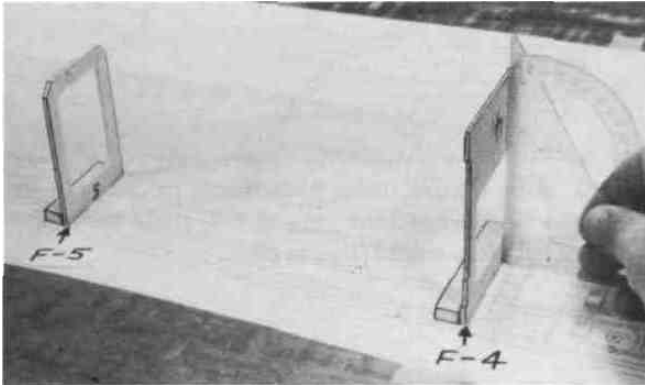

4. Trial fit formers **F-4** and **F-5** to the front of the Cross-braces (the formers are upside down), and sand the edges of the formers slightly to match the angle of the fuse sides. Glue the formers to the cross-braces, **making sure that each former is installed perpendicular to the building surface.**

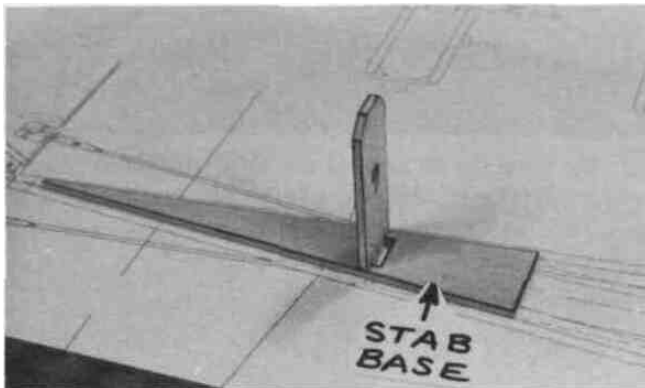

5, Insert **F-6** upside down in the **rear** of the slot in the stab base. Sand the edges of F-6 slightly to match the angle of the fuse sides. Align F-6 perpendicular to the stab base and glue it in place.



6. Accurately position the 1/8" die-cut ply **fuse top on**

the plan and hold it **securely** in place with pins, tape or weights (or you may spray it lightly with 3M "77" spray adhesive, to hold it firmly but temporarily down on the plan).

7. Trial fit (do not glue) the following parts together **Fuse top, fuse sides, die-cut 1/8" ply F-2, F-3, F-4** and the die-cut 1/8" ply **Chin Block Base**. Check the fit of all parts and trim, file or sand as necessary for a good fit. Pull the aft ends together and re-sand the 1/4" triangles if necessary.

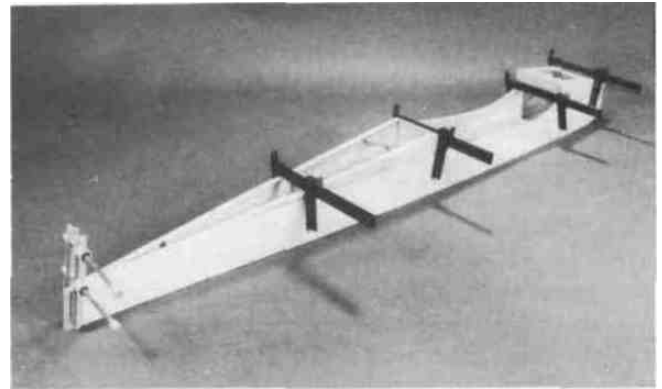

8. Once you have everything fitting properly, **re-assemble** the above parts, using clamps, pins, tape and weights to hold everything together and flat on the workbench. **Make sure F-2 is pushed as far forward as possible, and F-4 is pushed as far aft as possible.** There should be waxed paper underneath to prevent gluing the fuse to the plan. Apply thin CA glue to the joints, then follow with thick CA glue in any joints that are not tight fitting.

9. Sand the bottom of the fuse to remove any excess glue, and to provide a flat surface for the sheeting.

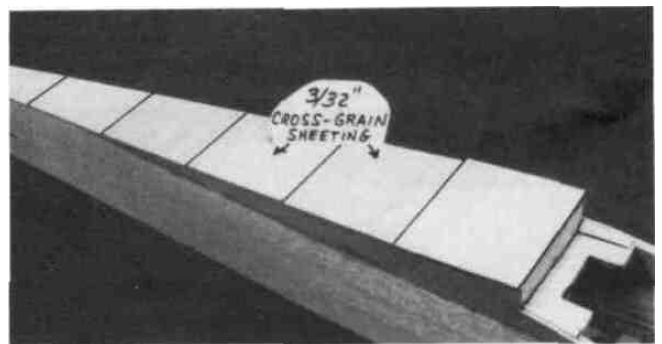

pieces of **cross-grain sheeting** to the bottom of the fuse, beginning at the front of F-4 and running to the aft end of the fuse.

11. Now you may remove the fuselage from the work surface and sand the edges of the bottom sheeting flush with the fuse sides.

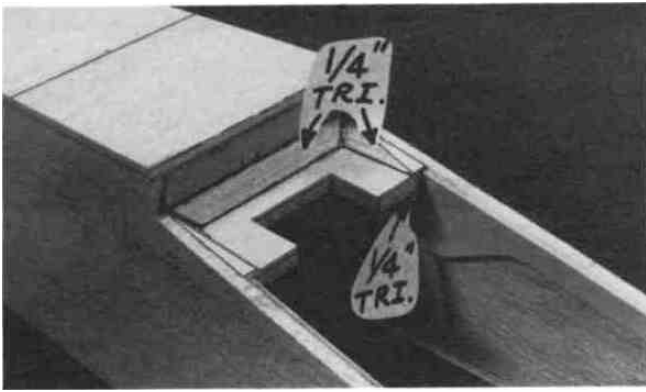

12. Find the 1/4" ply **wing hold-down block** and trial fit it into the notches in the fuse side doublers, sanding as necessary for a good fit. Glue the hold-down block in place **securely**, using 30-minute epoxy, then cut pieces of 1/4" balsa triangle and glue them in place above and below the hold-down block. Sand the triangles flush with the wing saddle.

13. The 1/4" ply firewall (F-1) location and size will vary, depending on which engine you install. The location has been set by the firewall spacers. The firewall supplied in your kit is the correct size if you are installing a .91 4-stroke engine; however, if you are installing a smaller engine, such as a .70 4-stroke or a .61 2-stroke, you will have to cut the firewall down to the correct size. The fuse plan shows the firewall sizes and engine mounting required for the three locations. Cut the firewall to size and sand the sides and bottom at an angle to match the fuse. Trial fit to make sure it will fit correctly before proceeding to the next step.

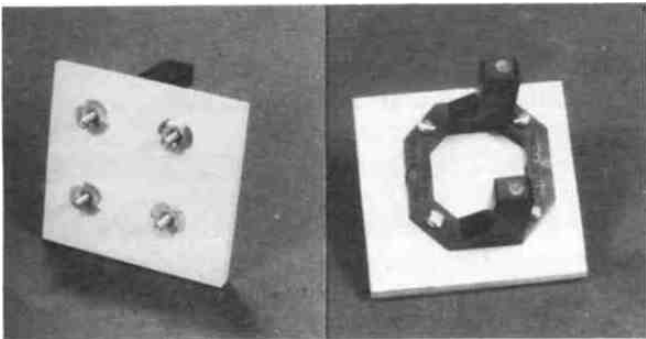

14. Before installing the **firewall** (F-1), you may drill F-1 for your engine mount and install the 6-32 blind nuts. You may cut out the appropriate F-1 drawing from the plans, tape it to F-1 and use it as a guide for drilling the four 5/32" holes. If you will be using a mount not shown on the plans you'll have to determine the correct mounting position. Note that the mount should not be positioned on the vertical and horizontal centerlines of F-1, but should be offset slightly above the centerline and slightly toward the left side. (When taking measurements off the plan, keep in mind that the plan shows the bottom view of the airplane). Drill the holes and install the blind nuts on the back of F-1, pressing them in with a pliers or a vise.



6-32  
Blind Nut

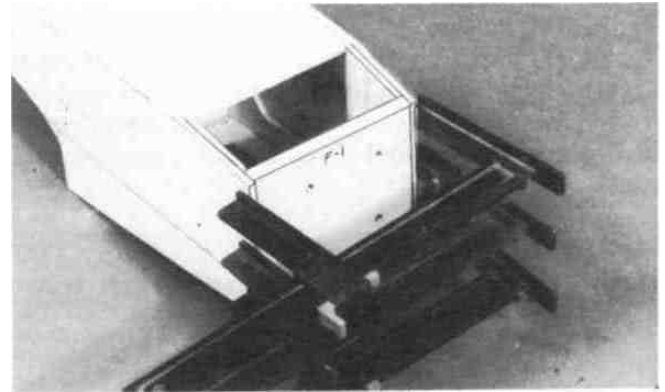

15. Use 30-minute or 5-minute epoxy to securely glue F-1 to the fuse sides, holding with clamps or tape until the glue has firmly set. **NOTE:** Before the glue sets, double check to make sure F-1 is properly aligned with the top and bottom edges of the fuselage, and fully back against the firewall spacers. After the glue has fully hardened, sand off the front of the fuse sides flush with the front of F-1.

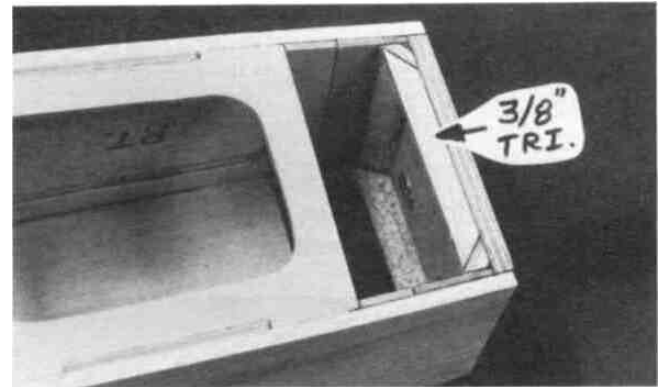

16. Cut pieces of 3/8" balsa triangle to fit around the aft edges of F-1, and glue them in place.

## DRILL ENGINE MOUNT (Great Planes MM60L mount)

1. Place the engine pointing straight ahead on the mount and mark the mounting hole locations on the mount. At the marked locations, accurately drill 7/64" (or #36) holes. **NOTE:** If you have access to a drill press, use it for drilling these holes to insure that they are drilled vertically.

2. Now you may use one of the following methods to attach your engine to the mount:

**Method 1:** Screw the #6 x 1" sheet metal screws (provided in the kit) through the engine mounting flange and into the mount. When first installing these screws, put a drop of oil into each screw hole.

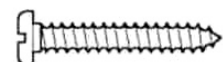

#6 x 1" Screw

**Method 2:** Cut threads into the holes you just drilled using a 6-32 tap and tap wrench. If you use this method you'll have to supply your own bolts (6-32 x 1" socket head cap screws) for attaching the engine to the mount. **NOTE;** 8-32 hardware is recommended if you are installing a 4-cycle engine.

## INSTALL SERVOS AND PUSHROD GUIDE TUBES

**NOTE:** Although you may choose to wait until later, this is the best time to install the pushrod guides, because the fuselage is wide open and it is very easy to work inside.

**IMPORTANT:** Before proceeding, **plan your servo and pushrod installation.** Especially note which side of the fuselage the throttle pushrod and nose gear pushrod (if any) will be located. Remember that the throttle arms of 2-cycle and some 4-cycle engines are on opposite sides. It will be helpful to actually sketch your pushrod locations on the plans with a pencil. It is desirable for the throttle pushrod (and the nosegear steering pushrod) to run along the **sides** of the fuselage. It is also desirable (but not essential) for the rudder and elevator pushrods to cross inside the fuselage, to avoid any sharp bends.

- 1. Set the fuselage upside down on blocks at least 1-inch high.

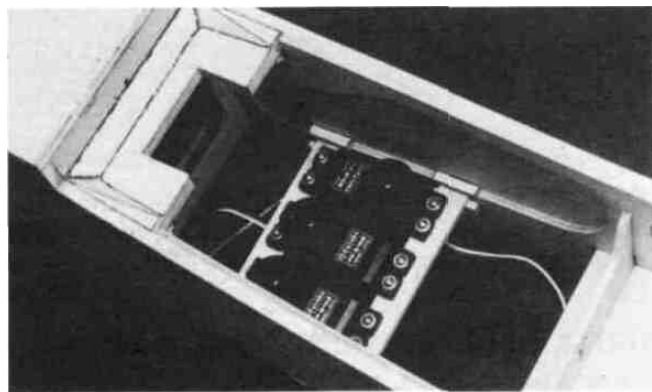

- 2. Trim the 3/16" x 1/2" x 3-5/8" ply **servo rails** to fit between the fuse side doublers in the locations shown on the plan. Temporarily mount your servos to the rails, then glue the rails to the fuse side doublers. Lock the rails in place by gluing scraps of plywood on the top and bottom of the rails.
- 3. Sand the outer surface of the **pushrod guide tubes** with 100-grit sandpaper to provide a surface to which the glue will adhere.

- 4. Use an Xacto knife to sharpen one end of a piece of 3/16" (outside diameter) brass tubing, then use this tubing to cut the **pushrod exit holes** (you may use a 3/16" drill bit, but

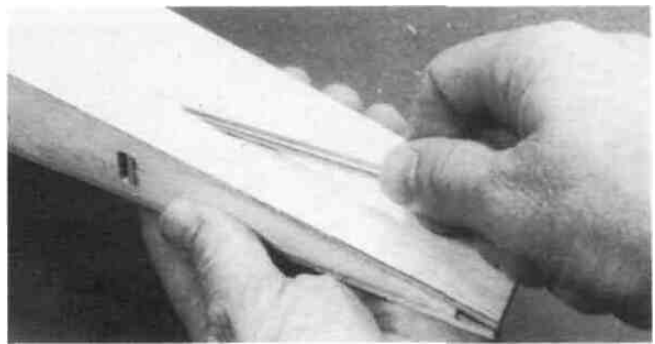

the brass tube method gives a much neater cut). Determine the location of these holes from the plans. You may chuck this brass tube in an electric drill to aid in getting through F-6.

- 5. Insert the plastic pushrod tubes through the holes you just cut and through formers F-6, F-5 and F-4.

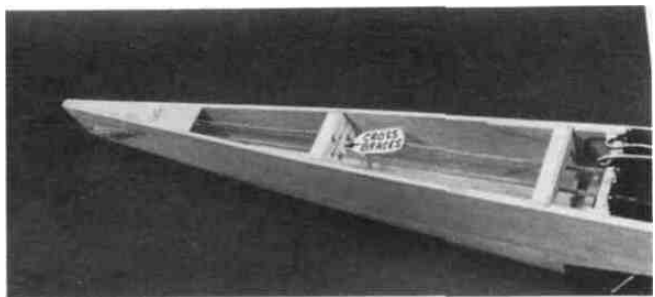

- 6. Route the pushrod tubes according to your radio installation plan. Temporarily insert the 34" pushrod wires into the tubes and hold them in the correct position at the servo end. **Keep the tubes as straight as possible.** Glue the tubes to the fuse sides at the rear exit points using thin CA glue. Use scraps of 1/8" balsa to anchor the tubes to F-5. **Do not anchor the tubes to F-4 at this time**, to allow for slight adjustment of their positions later.

- 7. Cut off the tubes at the exit points and sand them flush with the fuse sides using a sanding block.
- 8. Temporarily install the **engine mount, nosegear** (and **nosegear steering arm** if you are building a tricycle configuration).
- 9. **Cut 1/4" off the end of the steering arm**, then drill a 3/16" hole in F-1, just above the outer hole of the arm. **NOTE:** The drill should be aimed toward the rudder servo to avoid tight bends in the pushrod. The photo for this step is at the top of the next page.

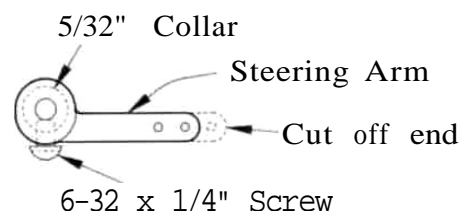

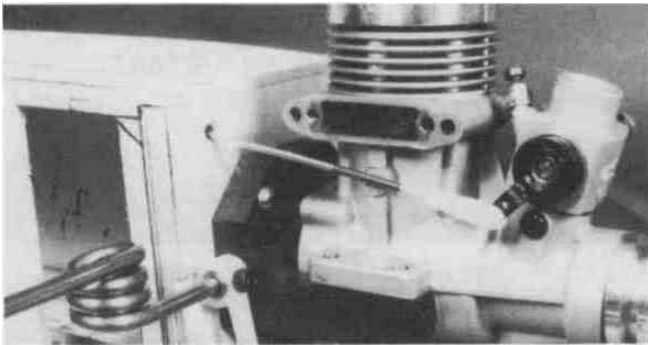

10. With the engine resting on the mount, plan the **throttle pushrod** routing. The pushrod should be located as close as possible to the fuse sides (to allow room for the fuel tank), and the guide tube should not have any tight bends. Drill a 3/16" hole in F-1 for the throttle pushrod guide tube.

11. Drill or carve holes in F-2 and F-3 for the guide tubes. Cut the remaining 36" plastic pushrod guide tube in half and trial fit the tubes in the fuselage. (Also see the photo on page 35.)

12. Sand the plastic pushrod guide tubes with 100-grit sandpaper, then glue them in place. Trim and sand the tubes flush with the front of F-1.

13. Cut the **pushrod** wires (supplied) to the required lengths and temporarily install the throttle and nose gear pushrods. **NOTE:** A 34" wire, threaded one end, is supplied for the throttle pushrod, and a 19" wire (no threads) is supplied for the nosegear pushrod.

14. Now remove the pushrod wires, engine, engine mount and servos.

## MOUNT THE WING TO THE FUSE

1. Sand the top surface of the fuse to remove any excess glue so the fuse will lie flat on the workbench.

2. Sand the entire wing saddle area lightly until the fuse side doublers and fuse sides are flush.

3. Insert the die-cut 1/8" ply **F-2A** in place against the back of F-2 (**do not glue**).

4. Insert the 1/4" wing dowels into the wing so they stick out only 1/8".

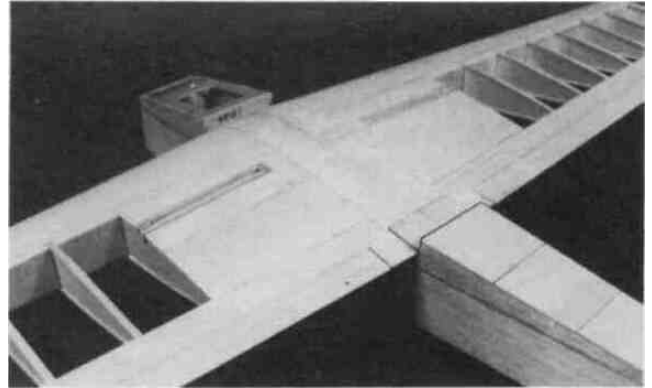

5. With the fuselage upside down on a flat surface, trial fit the wing into the wing saddle. If the wing is slightly too large (front to rear) to fit into the saddle, sand the rear edge of the saddle and the wing trailing edge slightly until it fits.

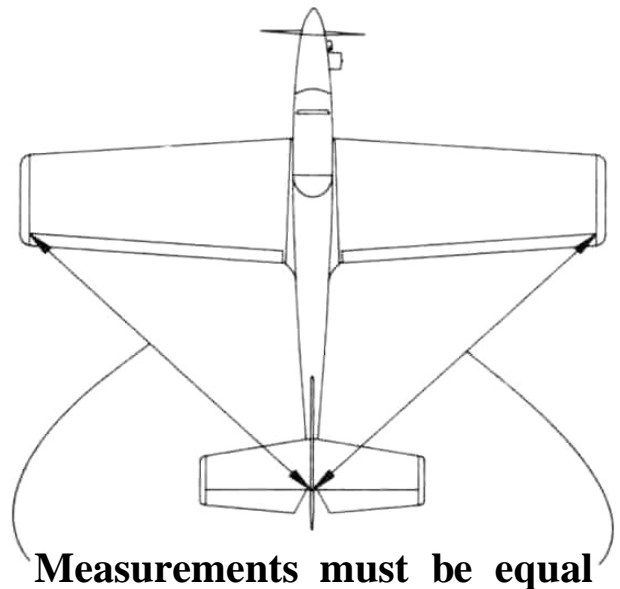

6. Carefully **align** the wing in the saddle as follows:

If you have drilled the dowel holes accurately, the wing should now be **centered**, side to side. Measure down from the bottom of both tip ribs to the flat surface. If the measurements are not equal (within 1/16"), sand the saddle slightly until the wing sits level in the saddle. Also measure from the rear corner of each wing tip to the tail end of the fuselage. These measurements must also agree within 1/16". If not, shift the wing slightly until they do. With the wing in this position you may now check the wing **incidence** using an "incidence

meter" or by measuring down to the flat surface from the center of the leading and trailing edges. The measurements should be the same (zero degrees incidence). **CAUTION:** If your flat surface is not **level**, you will get erroneous incidence readings! If you are working on a flat surface that is not level, you must set the wing incidence the same as your flat surface.

7. After making the necessary corrections to align the wing, **tack glue** F-2A to F-2 with a couple drops of CA. Also make **alignment marks** on the wing TE and the front of F-4 so you may easily re-align the wing later.

8. Remove the wing and **securely glue** F-2A in place by flowing thin CA into the wing dowel holes and around the edges. Follow up with thick CA in any gaps around the edges.

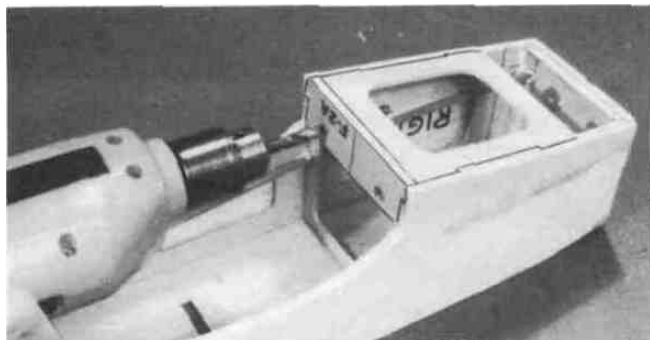

9. Drill 1/4" holes through F-2 using the holes in F-2A as a guide.

10. Use a pliers to grasp the ends of the wing dowels and pull them out. Now you may slightly round (or chamfer) the ends of the dowels for easier insertion into F-2A. Mix up a batch of 30-minute epoxy, use a long stick to work some epoxy into the dowel holes, smear epoxy on the dowels, then re-insert the dowels into the wing, leaving them protrude 3/8". Wipe away all excess epoxy, then allow the epoxy to fully harden.

11. Study the wing plan to determine where the **wing bolt holes** are to be drilled. By measuring, transfer the locations to the wing bolt plate on the bottom of the wing. After marking the bolt locations, replace the wing in the saddle and re-align it accurately, as in step 6.

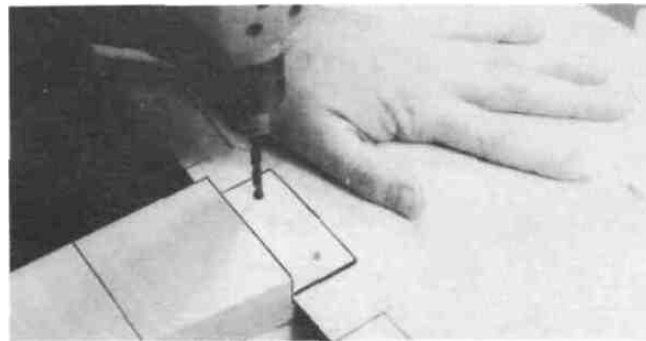
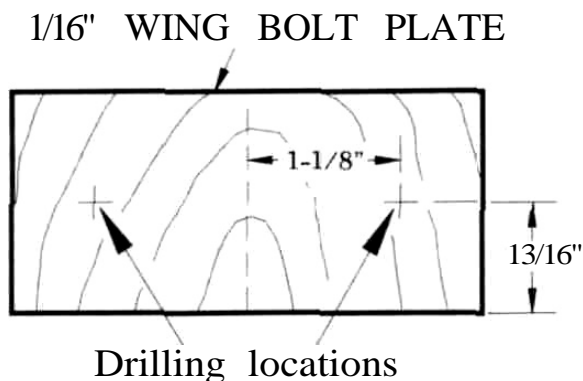

12. Holding the wing **firmly** in place, drill 13/64" holes at the locations you marked in step 11, drilling down through the 1/16" ply wing bolt plate and through the 1/4" ply hold-down block in the fuselage. Try to drill straight in, perpendicular to the 1/16" ply bolt plate. **IMPORTANT!: Do not allow the wing to move while drilling!**

13. Remove the wing and re-drill the holes **in the wing only** to 1/4".

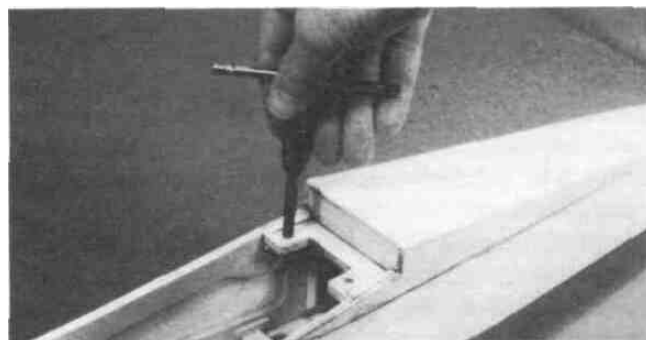

14. Use a **1/4-20 tap** and a **tap wrench** to cut threads in the ply hold-down block in the fuselage.

15. **Harden** the threads in the hold-down block with thin CA glue, then re-tap the threads after the glue is **completely dry**.

16. **Trial fit** the wing to the fuse using the two 1/4-20 nylon bolts provided. You may cut the bolts off to their proper length, so they protrude about 1/4" below the hold-down block in the fuselage.

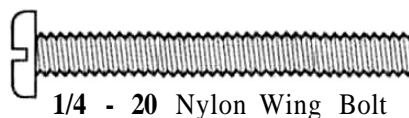

17. Later you will apply foam **wing seating tape** or **silicone sealer** to the wing saddle. To allow space for this wing cushion material, you may sand the saddle **slightly** in the areas where the wing touches the saddle, to provide a small gap.

18. Sand off the bottom edge of F-2 and F-2A flush with the bottom of the chin block base. And, while you're at it,

sand the entire fuse bottom, forward of F-2A, in preparation for installation of the chin block.

### FIT FUEL TANK and FUELPROOF TANK COMPARTMENT

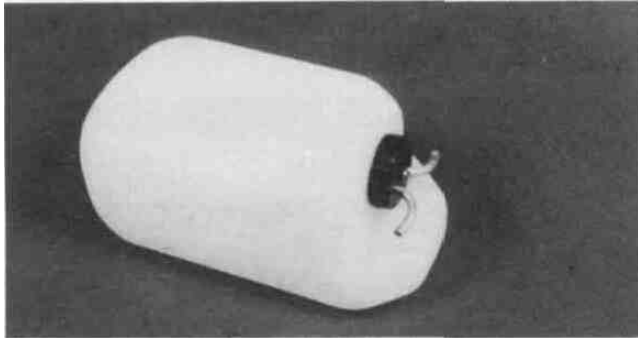

- 1. Assemble your 11 to 14 oz. fuel tank. We recommend bending the brass tubes as shown in the photo to prevent them from cutting through the silicone fuel lines if pressed against the firewall. (Try not to "kink" the tubes when bending, however).
- 2. Try sliding the tank in through F-2. If the opening is not large enough, sand or file the opening until the tank slides in easily.
- 3. Temporarily install the engine mount and note how far the mounting screws protrude into the fuel tank compartment. Remove the screws and cut them off so they do not protrude more than 1/8" (to prevent puncturing the fuel tank).



- 4. Drill two holes (7/32" or size to fit your fuel tubing) near the top of F-1 for your fuel tubing vent and fill lines. The location of these holes will depend somewhat upon the type of engine you are using, etc. It is OK to drill the holes in the upper left and upper right corners, but we prefer drilling both holes in the upper right corner (as viewed from the rear) for easier access.

- 5. Now remove the engine mount and **fuelproof** the inside of the fuel tank compartment and the front of F-1 by brushing on a coat of polyester resin or 30-minute epoxy thinned with alcohol. **NOTE:** Later when installing the nose pieces, you will fuelproof the chin block before installing it.

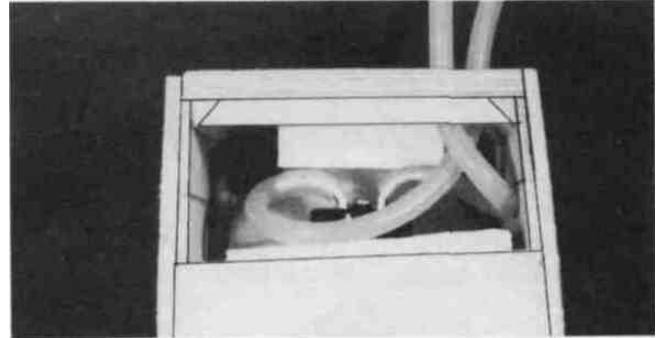

- 6. You may permanently install the **fuel tank** at this time, or you may wait until the plane is nearly completed. If you do it now it will be easier to feed the fuel lines through F-1, and to make sure there are no kinks in the lines; however, you'll have to work around them while completing the nose. When you install the tank, be sure to cushion it from vibration and prevent it from moving by surrounding the tank on all sides (and front) with latex foam rubber. Leave a few inches of extra fuel tubing in front of F-1 (you can cut off the excess later). The photo shows how to route the fuel tubing to prevent kinking.

### INSTALL TURTLE DECK

You'll need the following parts: Die-cut 1/8" ply **F-3A**, F-4A, and **Backrest Gauge (BG)**; die-cut 1/8" balsa F-5A and F-6A; two 1/4" x 1/4" x 27" balsa **turtle deck stringers**; two 3/32" x 3-1/4" x 28-1/4" balsa **turtle deck sides**; the 1/2" x 2-3/8" x 26" balsa **turtle deck top block** and a roll of masking tape.

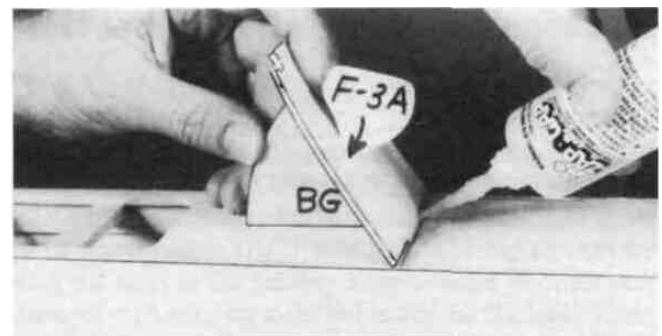

- 1. Glue the die-cut 1/8" ply "backrest" (F-3A) to the fuse top, using the "backrest gauge" (BG) to set it at the

correct angle. **NOTE:** The gauge is used only for setting the angle (do not glue the gauge in).

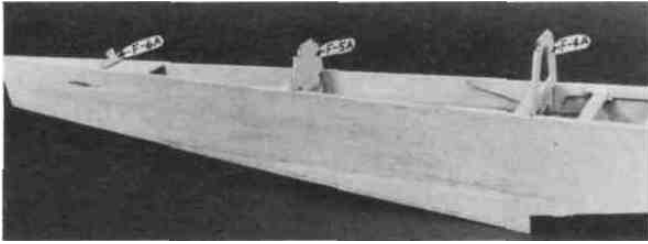

- 2. Glue **F-4A** to the front of F-4.  
Glue **F-5A** to the front of F-5.  
Glue **F-6A** to the front of F-6 (insert the F-6A tab through the slot in the stab base).



- 3. Glue the 1/4" x 1/4" x 27" balsa **stringers** to the formers. **HINT:** If F-3A is slightly warped, you may straighten it during this step by twisting it straight while gluing the stringers. Trim and sand the ends of the stringers flush with the front of F-3A and the rear of F-6A.

- 4. Use a sanding block to sand the sides of the stringers to blend with the formers (see the cross-section drawings on the plan). Also use a long sanding block to sand the stringers and the tops of the formers in a straight line from F-3A to F-6A.

- 5. Prepare the **turtle deck sides** by cutting the two 3/32" x 3-1/4" x 28-1/4" balsa sheets to the angle shown in the following sketch.

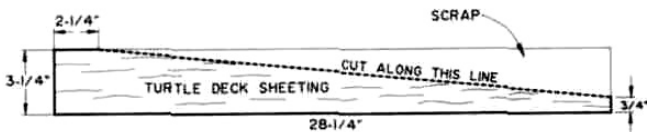

- 6. **Trial fit** one edge of the sheering down onto the top of the fuse side. Sand the edge of the sheering if necessary, for a good fit



- 7. Glue the bottom edge of the sheering to the top of the fuse sides.

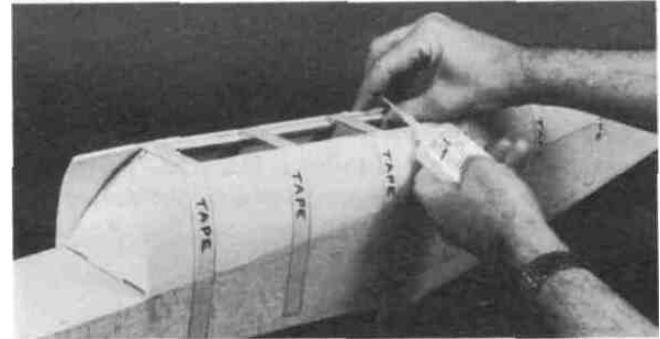

- 8. Wet the outside surface of the sheering with a damp rag to permit easier bending. Apply thick CA glue to the edges of the formers and the stringers, then immediately bend the sheering around the formers and onto the stringers. **HINT:** This requires about 5 sets of "hands," so use several long pieces of masking tape to pull the sheering together; then, working a small section at a time, add CA and press the sheering to the stringers.

- 9. Trim and sand the sheering flush with the front of F-3A and the rear of F-6A.

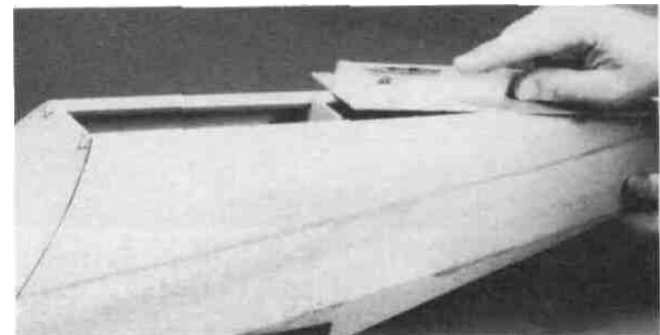

- 10. Using a long T-bar or sanding block with 80-grit sandpaper, sand the sheering and stringers flush with the **top edges** of the formers.

**NOTE:** The turtle deck is designed to be as light as possible, while still providing sufficient durability for normal use. If your airplane will be handled by "ham-fisted" people who like to squeeze hard when holding the airplane in the turtle deck area, you may want to add an extra 1/4" x 1/4" balsa stringer on the inside of the turtle deck sheeting, between F-3A and F-4A, about halfway down.

11. Glue the 1/2" x 2-3/8" x 26" balsa **turtle deck top block** to the tops of the formers, stringers and sheeting, then trim the ends of the top block flush with F-3A and F-6A.

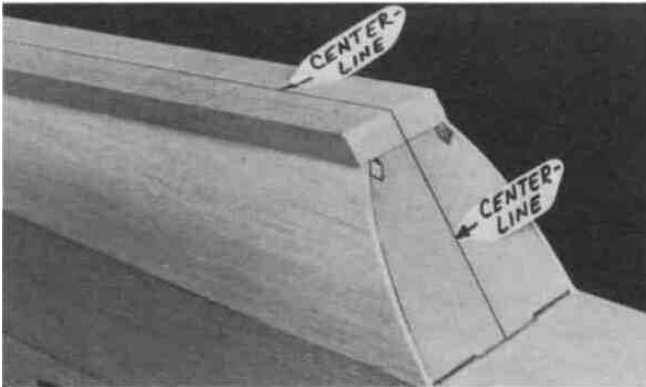

**HINT:** In the next step it will be helpful in keeping the top block symmetrical if you first mark a centerline on the top of the top block from front to back (this is a line from the centerline of F-3A to F-6A).

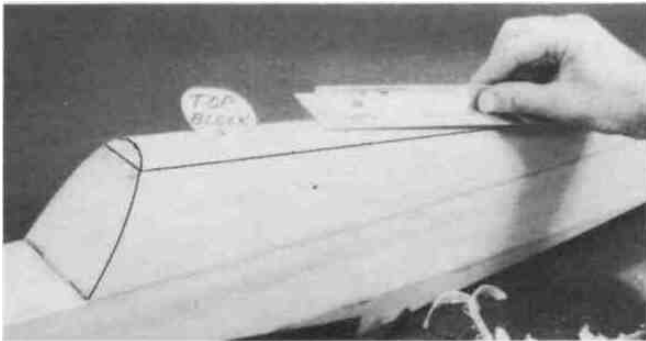

12. Carve and sand the top block to blend smoothly with the sheeting (see the cross-sections on the plan). **HINT:** Use a razor plane (or a sharp wood chisel) and a sanding block with 50-grit sandpaper for rough shaping the top block.

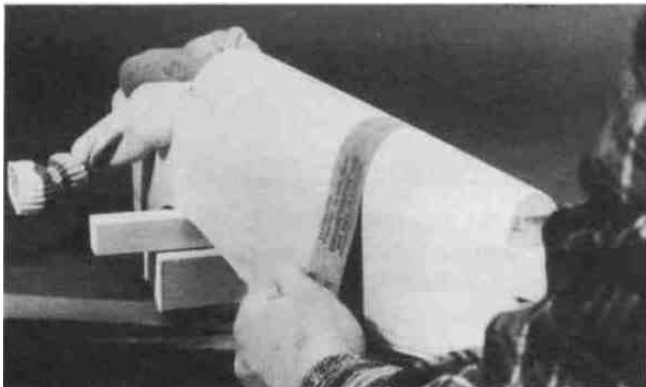

**HINT:** For a super-smooth and uniform finish on your turtle deck, cut a 2-1/4" x 11" strip of 320 or 400-grit wet-or-dry sandpaper, and work it like a "shoe-shine cloth" across the top of the turtle deck.

## ASSEMBLE THE NOSE SECTION

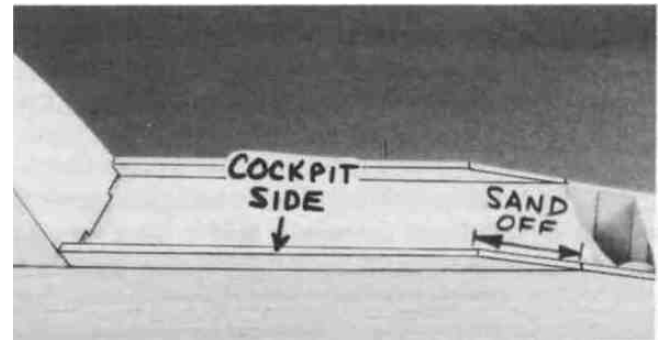

1. Find the 1/4" x 1/4" x 10" balsa **cockpit sides**. Cut off one end of each stick at an angle to fit the front edge of the backrest (F-3A).
2. Glue the cockpit sides to the top edge of the fuse sides and to F-3A. The outside edge of the cockpit sides should be flush with the outside edge of the fuse sides.
3. Measure, mark and sand off the cockpit sides according to the sketch. Then sand the top front corners of the fuse sides on the same angle, to blend with the cockpit sides.

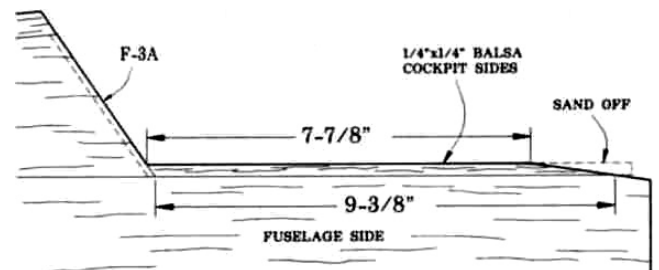

4. Attach the engine mount to F-1, and attach the engine to the mount. Remove the nose gear.
5. From a scrap of 1/32" ply, cut four small pieces and tack glue them to the 1/16" ply **spinner ring** as shown, using a very small amount of thick CA (these will be removed later). **IMPORTANT NOTE:** If you have chosen to use shock-absorbing rubber engine mounts, then you must provide more space between the spinner ring and the spinner

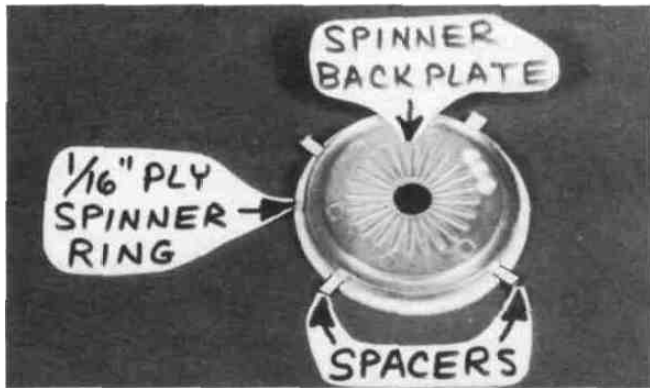

backplate to allow for engine movement. (A space of approximately 1/8" is probably sufficient).

- 6. Now center your 2-3/4" diameter spinner backplate over the spinner ring, and tack glue it to the 1/32" ply spacers.
- 7. Slide the spinner ring / spinner backplate assembly onto the driveshaft and temporarily hold in place with the prop and prop nut

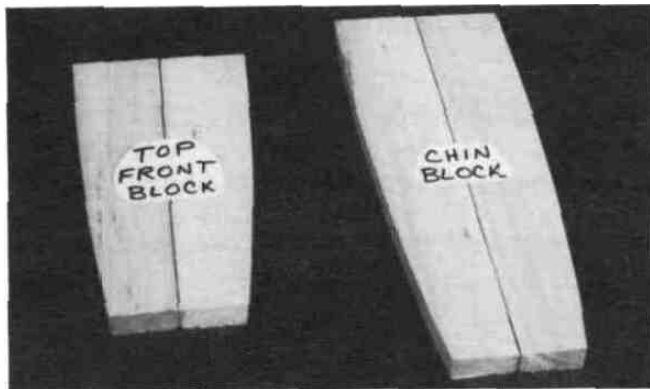

- 8. Glue together the two halves of the 5/8" balsa chin block and the 1/2" balsa top front block. Sand the glue joints smooth with your T-bar. **Fuelproof one side of the chin block.**

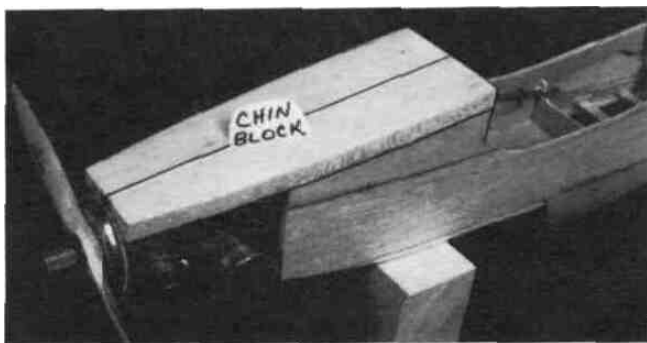

- 9. With the fuselage upside down, lay the chin block in place on the fuse bottom (fuelproofed side toward inside of fuse). Note how the front of the chin block meets the spinner

ring. By trial and error, sand a little at a time off the front of the chin block until it mates at the proper angle with the back of the spinner ring.

- 10. Glue the chin block to the bottom of the fuse and the spinner ring. You may want to use 5-minute epoxy for this step to allow some time for careful positioning.
- 11. Cut off and sand the aft end of the chin block flush with the aft edge of F-2A.

**NOTE: If you are building a taildragger, disregard steps 12 and 13.**

- 12. Turn the fuselage right side up and use a long 5/32" drill bit (or a sharpened piece of 5/32" O.D. brass tube) to drill a hole in the chin block for the nosegear wire. Insert the drill through the holes in the engine mount and drill down through the chin block.



- 13. Temporarily install the nose gear, steering arm and nosegear pushrod wire. Notice that the pushrod wire will bind against the chin block in a right turn. Carve out a clearance slot for the nosegear pushrod in the chin block. Now remove the nosegear parts.

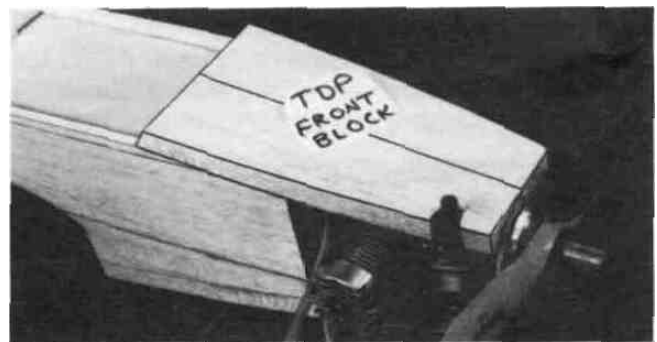

- 14. Lay the top front block in place on top of the fuselage. Using the same procedure as you used for the chin block, sand off the front of the top front block to mate with the spinner ring. Depending on your engine, you may also have to carve a groove for the needle valve. In addition, check if your engine mount touches the top front block, and provide

clearance as necessary. Glue the top front block to the fuse and the **spinner ring**.

- 15. Cut off the aft end of the top front block at the location and angle shown on the plan (measure forward from F-3A).

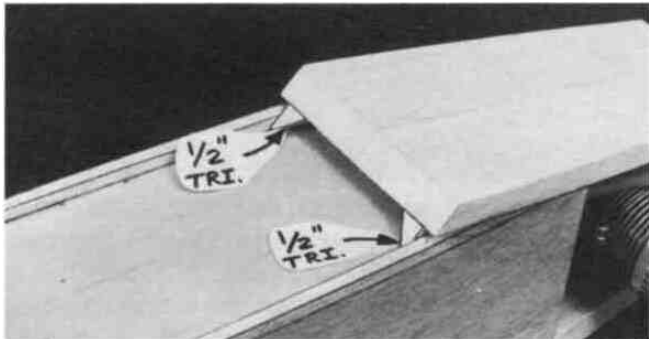

- 16. Cut two 1" lengths from the 1/2" x 11-1/2" balsa triangle and shape them to fit under the top front block, just **in** front of the dash. Also cut two scraps of 1/4" balsa to fill the gap between the top front block and the cockpit sides (see the DASH detail drawing on the fuse plan). Glue in place.

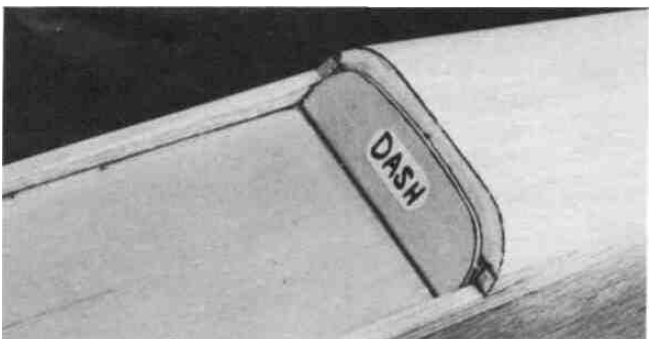
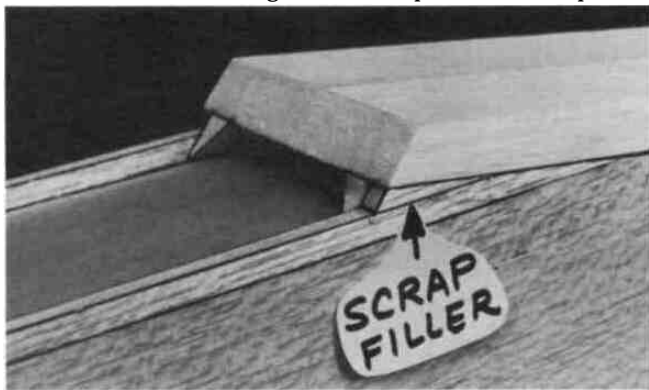

- 17. Sand the sides of the die-cut 3/32" balsa **dash** to fit between the cockpit sides, and sand the bottom edge to an angle so it rests flat on the cockpit floor. Glue the dash **in** place.

- 18. Remove the prop nut and propeller. Pop the spinner backplate loose with a screwdriver and remove the spacers. You may remove the engine and mount in preparation for the next step. Mark the outline of the engine mount on F-1 with a pencil. **HINT:** After removing the engine, enlarge the hole in the spinner ring as necessary until you can easily access the engine mount screws with a long screwdriver.

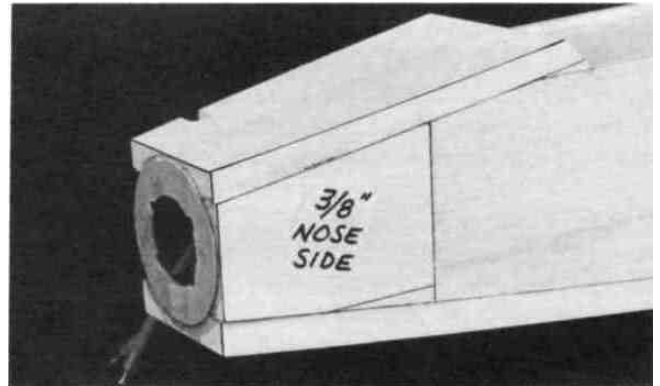

- 19. A 3/8" x 3" x 9-7/8" balsa sheet is provided for the **nose sides**. From this sheet, cut pieces to fit on the left side of the fuselage between the chin block, top front block, F-1 and the spinner ring. To do this more easily you may remove the engine and mount, then lay the fuse on its left side on top of the 3/8" balsa sheet and mark the outline of the opening on the sheet. (When installing this block, make sure you stay clear of the engine mount).

- 20. If necessary, carve out an area of the nose side needed for nosegear steering arm and pushrod clearance, then glue the left nose side in place.

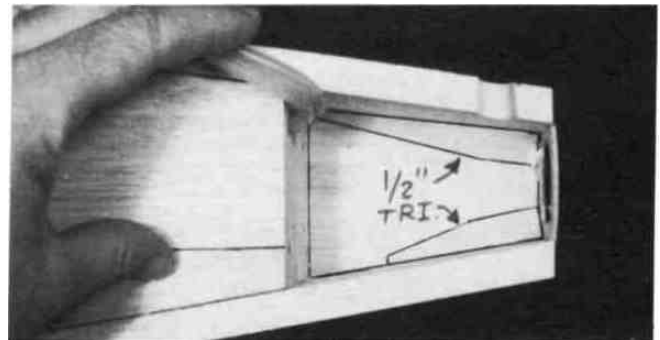

- 21. From the 1/2" balsa triangle stock provided, cut lengths to fit in the upper left and lower left corners of the nose, between F-1 and the spinner ring. Sand these balsa triangles to a **taper**, with the wide part at the front, and glue in place.

- 22. Temporarily re-install the engine and mount; then, from the remaining 3/8" balsa sheet and 1/2" balsa triangle, cut pieces to partially fill in the **right side** around the engine.

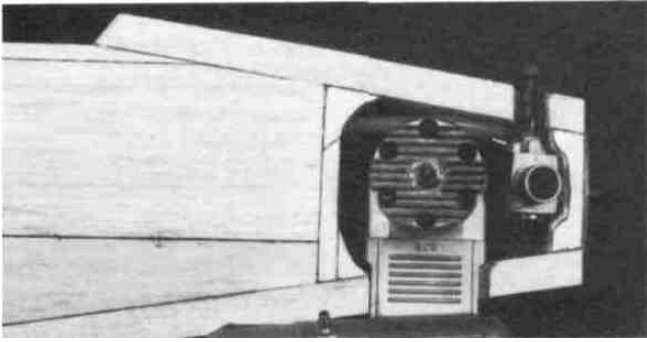

Also, trim the balsa as necessary to clear your muffler. **SUGGESTION:** The temptation is to close up this area too much! We recommend that you leave large enough openings that you may easily remove the engine and mount, and so you will have convenient access to the throttle linkage.

- 23. Now, with the engine and mount removed, **fuelproof** the inside of the entire engine compartment **with** polyester resin or epoxy thinned with alcohol.

## FINAL ASSEMBLY

### SAND THE FUSELAGE

**NOTE:** Some heavy sanding is required to properly shape the nose area. This task can be made much easier if you use a razor plane and a sanding block with #50-grit sandpaper for rough shaping. The very coarse sandpaper is used to achieve the basic shapes, then use progressively finer grades of sandpaper for a smooth finish.

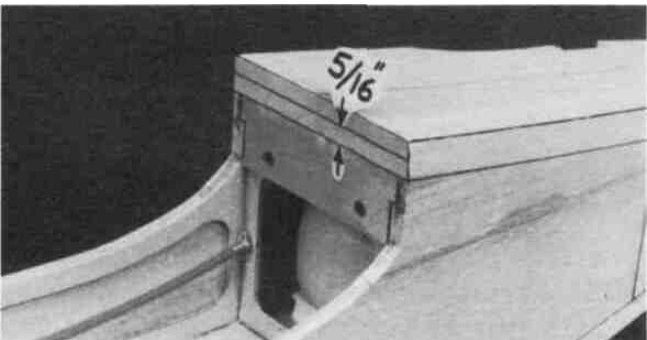

- 1. Turn the fuse upside down and draw a line on the aft end of the chin block  $5/16$ " below the bottom edge of F-2A. Now study the fuse plan side view and note the final shape and curvature of the chin block. Use your razor plane and a sanding block with coarse sandpaper to sand the fuse bottom to the approximate shape as shown on the plan.

- 2. In the same manner, sand the top front block to the approximate shape shown on the fuse plan side view.

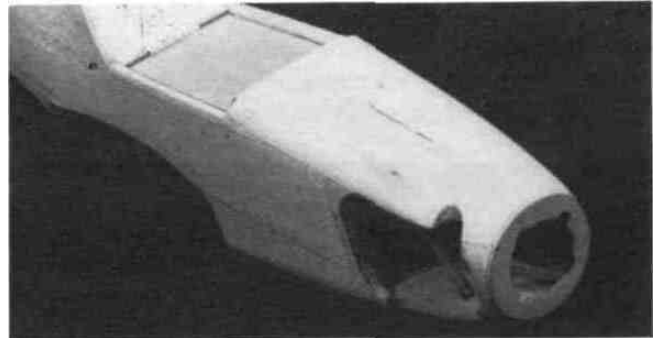

- 3. Now sand the chin block, the top front block comers and the nose side pieces to blend smoothly with the spinner ring. Refer to the cross-section drawings of F-1 and F-2 on the plan to get an idea of the desired amount of rounding in the comers. The top front block should be sanded with reference to the **dash** (see the DASH detail drawing on the plan).

- 4. After the rough sanding has been completed, temporarily re-mount your engine and slide on the spinner backplate. You'll probably have to sand the edges of the spinner ring down for a good match with the spinner backplate.

- 5. Sand the bottom rear comers of the fuselage **to a** slight radius as shown on the cross-sections of F-4, F-5 and F-6.

### INSTALL WING FAIRINGS

You'll need the following parts:  $3/4$ " x  $2-7/8$ " x 4" balsa block,  $1/2$ " x 3" x  $4-1/8$ " balsa block,  $1/4$ " x 3" x  $4-3/16$ " balsa block, and the 1" x  $2-7/8$ " x  $4-1/4$ " tapered balsa wedge.

- 1. Mount the wing to the fuselage with the nylon bolts.

- 2. Draw **center-lines** on all the blocks, then arrange them as shown in the sketch. Draw straight lines along the edges of the blocks as shown, and trim the blocks.

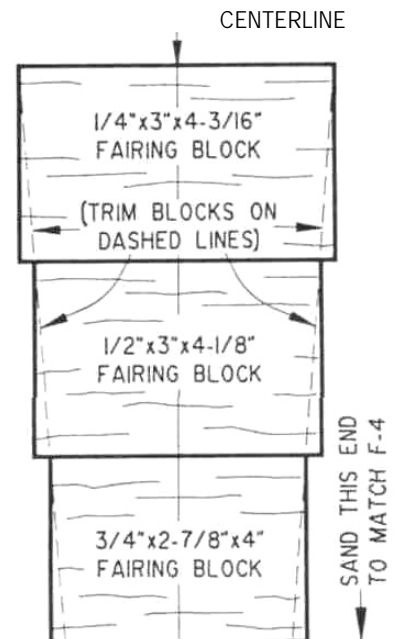

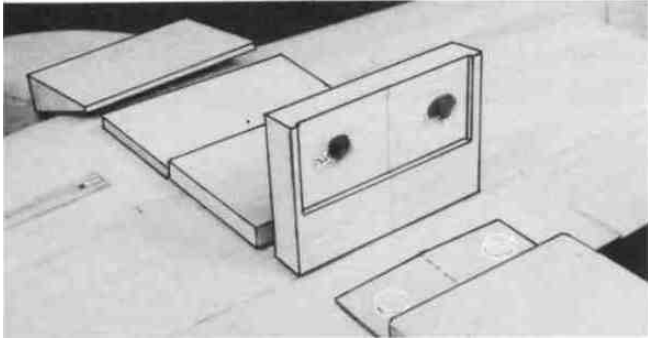

3. Sand the aft edge of the 3/4" x 2-7/8" x 4" balsa **rear fairing block** to an angle to match F-4, then position it on top of the nylon bolts, centered between the fuse sides. Push down on this block to make imprints of the nylon bolt heads in the fairing block.

4. Make holes in the fairing block large enough to clear the heads of the nylon bolts.

5. Again hold the fairing block in position, pushing down to imprint the location of the 1/16" ply wing hold-down plate on the fairing block. Carve the fairing block to clear the wing hold-down plate

6. Make a 1/2" deep saw cut down the center of the rear fairing block (cut from the side facing the wing), which will permit the block to bend to the shape of the wing.

7. Hold the rear fairing block in place, leaving a slight (1/32") gap between the back of the block and the front of F-4, and apply a couple drops of thin CA to tack it in place. Remove the wing bolts and remove the wing from the fuse, then glue the block securely in place.

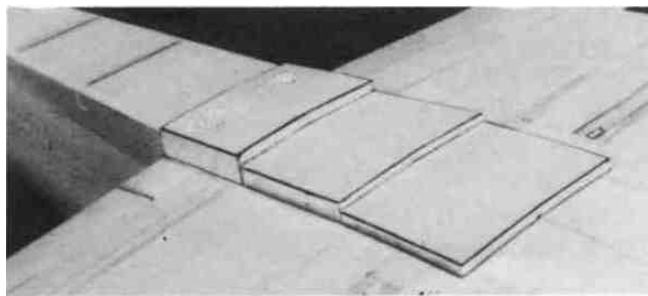

8. Glue the two remaining rear fairing blocks to the bottom of the wing in a similar manner. You'll have to make saw cuts in the center of the 1/2" block and the 1/4" block to permit bending at the centerline.

9. Carve and sand the 1" x 2-7/8" x 4-1/4" tapered balsa

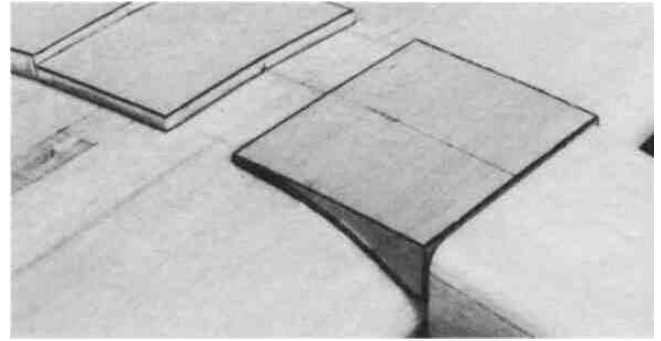

**front fairing wedge** to fit the top of the wing. Round the corners of the block to match the fuselage. **NOTE:** It is difficult (and not necessary) to carve this block to mate exactly with the wing; therefore, you should just "rough it out", then later you can fill any gaps with balsa filler.

10. With the wing in place on the fuse, hold the front fairing in place (allow 1/32" gap between the fairing front and the rear of F-2A) and tack glue it to the wing. **CAUTION: Use extreme care to avoid gluing the wing to the fuselage!**

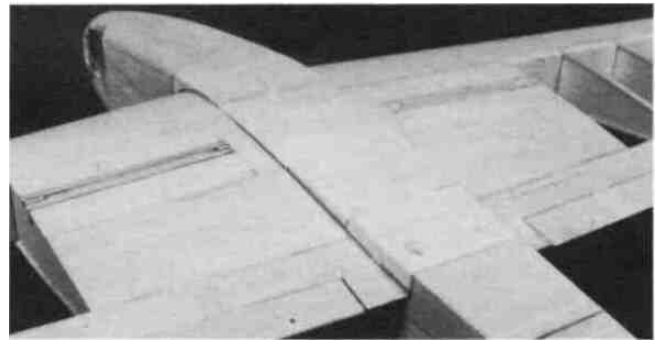

11. Remove the wing and securely glue the front fairing block to the wing. Fill all gaps with balsa filler. After the filler has dried, replace the wing on the fuse and sand all the fairing blocks to smoothly blend the wing to the fuselage.

## INSTALL WING FILLETS (OPTIONAL)

**NOTE:** The wing fillets are a nice addition to the US60. They make it more pleasing to the eye and they do help to reduce drag. The US60 flies just fine without them, however, so the choice is yours whether or not to install them.

1. Tape an 8" x 15" piece of waxed paper onto the top surface of the wing at the center, then attach the wing to the fuse with the wing bolts.

2. Lay the die-cut 1/32" ply wing fillet bases on the wing and glue them to the fuselage sides. **NOTE:** For this procedure, we recommend that you use **thick** CA glue Spar-



ingly, and "kick" the glue with accelerator spray immediately after applying, to avoid accidentally gluing the wing to the fuse with "stray" glue. **NOTE:** Bend the aft 1-1/2" of the fillet base to horizontal (see sketch).

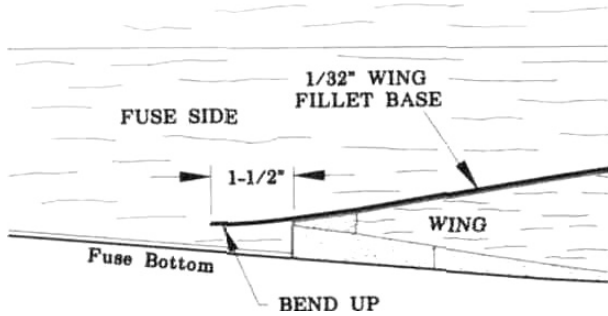

**Method 3:** A combination of the above, where you first glue pieces of balsa to partially fill the fillet area, then add filler to form the fillet shape.

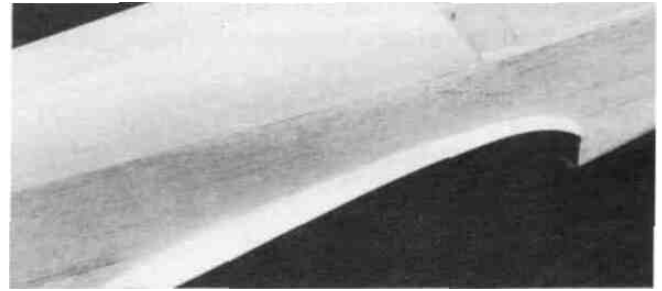
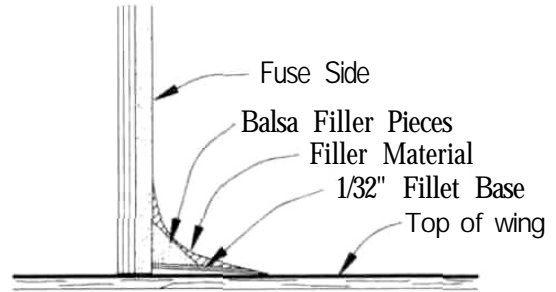

## SHAPE THE FIN FILLETS

3. You may build the fillet on top of the fillet base in one of the following ways:

**Method 1:** Glue pieces of soft balsa onto the fillet bases, then sand to the fillet shape.

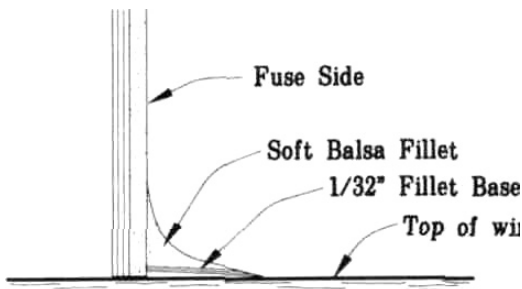

Method 2: Apply a good quality, lightweight model filler, shape it with a wet teaspoon, and allow it to dry **thoroughly** before sanding.

1. Using only one or two small drops of glue on each piece, tack glue the following balsa parts together (see sketch):

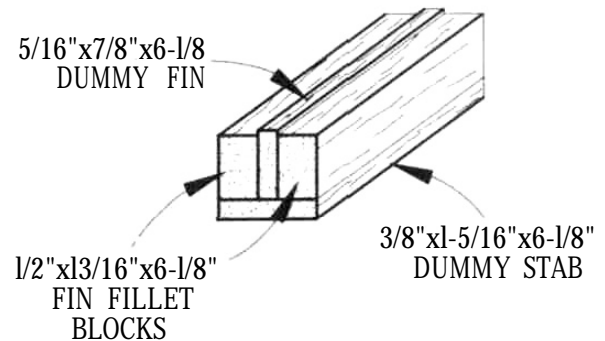

2. Tack glue the above assembly to the stab saddle with **the** "dummy fin" centered on the fuselage centerline.

3. Carve and sand the above assembly to blend smoothly with the fuse sides and the turtle deck. (The photo for this step is at the top of the next page).

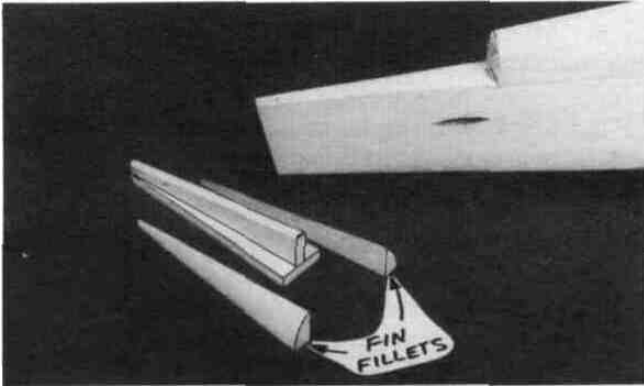
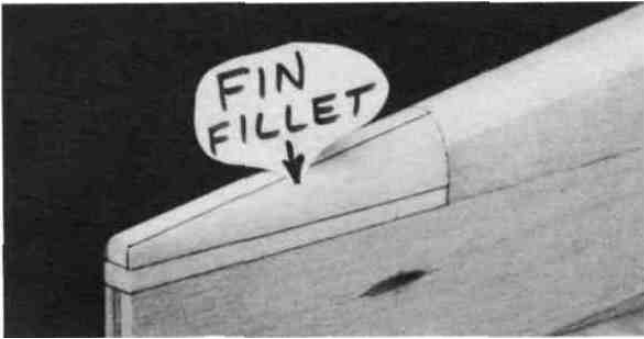

- 4. Break the assembly off the stab saddle and cut the parts apart. Save the shaped fin fillets for later.

## MOUNT STABILIZER AND FIN

- 1. Make sure the stab base is securely glued to the fuse sides, then lightly sand the **stab saddle area** smooth with a T-bar or sanding block.

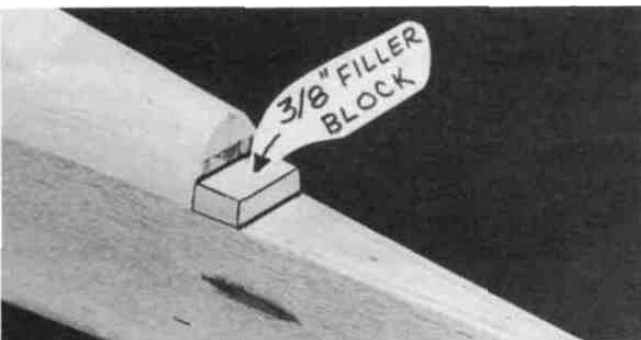

- 2. Find the 3/8" x 11/16" x 1-3/8" balsa **stab filler block** and glue it to the stab saddle and the back of F-6A. Sand off the ends flush with the fuse sides.
- 3. Accurately measure the trailing edge of the stabilizer and mark the center point

- 4. Temporarily mount the wing in the saddle (for reference), and block up the tips until the wing is level.

- 5. Lay the **stab** in position on the stab saddle with the center point lined up with the tail end of the fuselage. If the stab protrudes beyond the end of the fuselage, sand a little off the front of the stab until it fits. Carefully check the stab alignment by measuring down from the tips to a flat surface, and from the stab tips to the wing tips (or to a point on the center of the fuse near the nose). Sand the stab saddle (a little at a time!) until the stab rests in proper alignment. With the stab in alignment, make a mark on the front of the stab and a corresponding mark on the back of F-6A, which will be used for rapid alignment when gluing.

- 6. Mix up a batch of 5-minute or 30-minute epoxy and apply it to the stab saddle. Press the stab into position and **hold or pin in proper alignment until the glue has firmly set**. Wipe off any excess epoxy before it sets up.

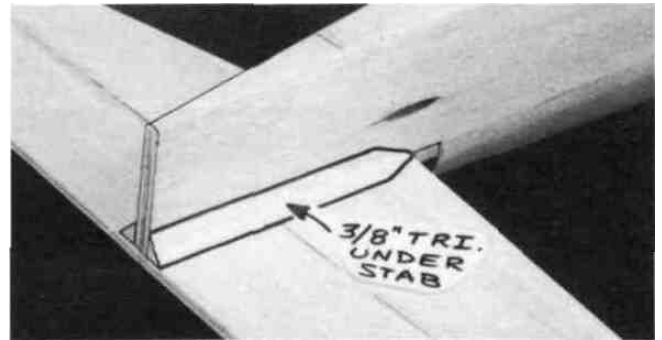

- 7. From the 3/8" balsa triangle supplied, cut and securely glue fillets **under the stab**, at the stab/fuse joint

- 8. Trial fit the **fin** on the stab. The fin trailing edge must line up with the aft end of the fuselage. If the fin protrudes too far aft, sand a small amount off the **front** of the fin.

- 9. Carefully align the fin on the stab. **The fin must be positioned perpendicular to the stab and must line up with the fuselage centerline EXACTLY!** Securely glue the fin in place.

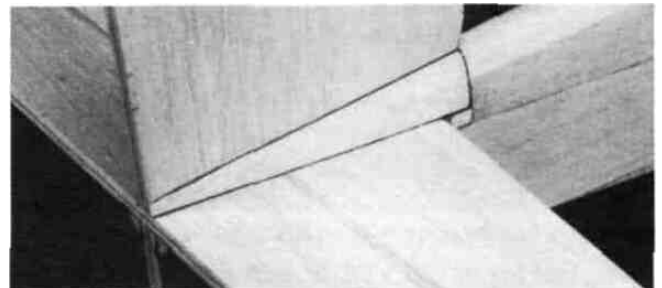

- 10. Now securely glue the **fin fillets** (you previously shaped these) in place on both sides of the fin.

- 11. Temporarily attach the elevators and rudder to check their fit and operation. Note that you must cut a **notch** in the rudder leading edge to clear the 1/8" wire elevator joiner.

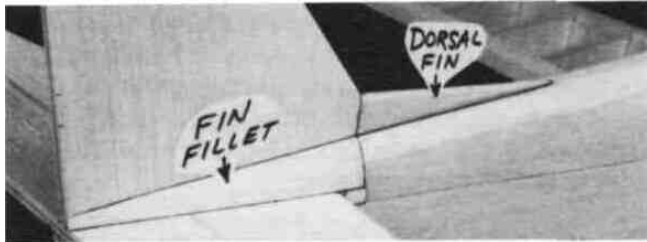

- 12. Finally, glue the 5/16" balsa **dorsal fin** in place on the turtle deck. The dorsal fin, like the fin, must also line up with the fuselage centerline. Sand the dorsal fin to a rounded shape, and blend it to the fin with balsa filler.

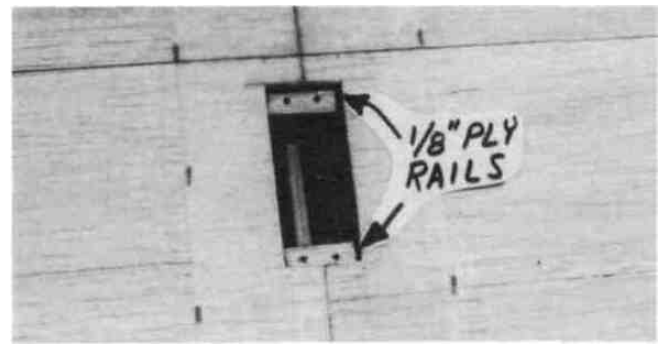

scrap, and glue them in place. (See the side view of the aileron servo installation on the plan).

- 4. Mount the **aileron servo** using the screws provided with your radio.
- 5. Screw the nylon **aileron clevises** approximately 2/3 of the way onto the threaded end of the two 12" steel wire pushrods.



**Nylon Aileron  
Clevis & Conn.**

- 6. Screw the nylon **aileron clevis connectors** onto the aileron torque rods.

## INSTALL SERVOS, HORNS AND PUSHRODS



- 1. Study the plans to determine the location of the **aileron servo cutout**. Mark the location on the top of the wing and cut an opening in the fiberglass and sheeting slightly larger than your servo. **CAUTION: Do not cut into the wing spars or shear webs!**

- 2. Remove a sufficient portion of the W-1 ribs to fit your servo, leaving "shelves" on which to glue the 1/8" ply rails. (See the plan to determine the depth). **NOTE: A Dremel Moto Tool with a 1/8" router bit is excellent for this, but it may also be done with an Xacto knife and a long-nose pliers.**

- 3. Make two **servo rails** from the 1/8" ply die-cutting

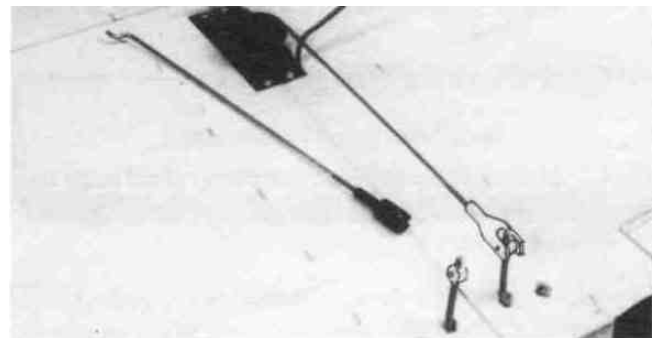

- 7. Attach the clevises to the clevis connectors, then, with the ailerons in the neutral position, mark the pushrod wires where they cross the holes in the servo arm. Remove the pushrods and make a "**Z-bend**" in the rods at that point, using a "**Z-bend pliers**" or a standard pliers.

- 8. Remove the servo wheel from the servo and work the Z-bends into the wheel (**NOTE: You may have to enlarge the servo wheel holes with a 5/64" diameter drill bit**). Replace the servo wheel and check the operation of the ailerons. (See page 35 for the recommended amount of aileron movement).

**REMEMBER: Plan** your servo installation carefully, as your setup may differ from the plans and photos, depending on which engine you use, and whether you are building a trike or taildragger.

- 9. Re-mount the elevator, rudder and throttle **servos** in the fuselage.

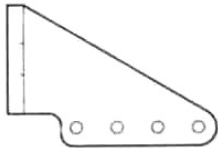

**Nylon Control Horn**

- 10. Hold the **nylon control horns** on the elevator and rudder in the positions shown on the plan and mark the mounting hole locations. Drill 3/32" holes at these locations.

11. **Harden the balsa** in the area of the control horns (on both sides of the control surfaces) by poking several holes with a pin, then applying thin CA glue. Sand smooth.

- 12. Mount the horns with 2-56 screws and the nylon **nutplates** which were attached to the horns.

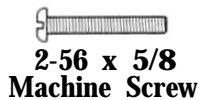

**2-56 x 5/8 Machine Screw**

- 13. Screw a nylon clevis onto the threaded end of each long steel wire pushrod. **NOTE: Screw them on all the way until the threads are protruding inside the clevis.**

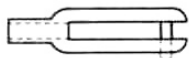

**Nylon Clevis**

- 14. Cut the short length of 1/8" diameter plastic tube into several pieces, approximately 1/4" long. Slide at least six of these pieces onto each of the long pushrod wires and space them approximately 2-1/2" apart (do not glue yet). **NOTE:** If these tubes do not slide on easily, cut them to a shorter length.

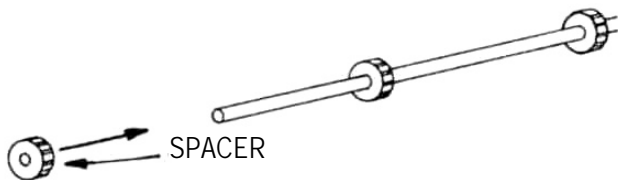

**NOTE:** While installing the pushrods, position the above plastic tube spacers so they always stay inside the pushrod guide tubes. If the tubes are not a tight friction fit on the pushrod wires, apply a drop of thin CA to secure them.

- 15. Insert the **pushrod wires** into the pushrod guide tubes (previously installed) and attach the clevises to the elevator and rudder horns.

- 16. While holding the rudder and elevators in the **neutral** position, mark where the pushrod wires cross the holes in the servo wheels where each pushrod will be attached.

- 17. Remove the elevator and rudder pushrods and make "Z-bends" at the marks you just made. Cut off the excess pushrod wire.

- 18. Unscrew the nylon clevises, re-insert the pushrods, and replace the clevises. Remove the servo wheels and work the Z-bends into the holes (drill out the holes in the servo wheels to 5/64" if necessary). Finally, place the servo wheels back onto the servos and check the operation of the elevator and rudder.

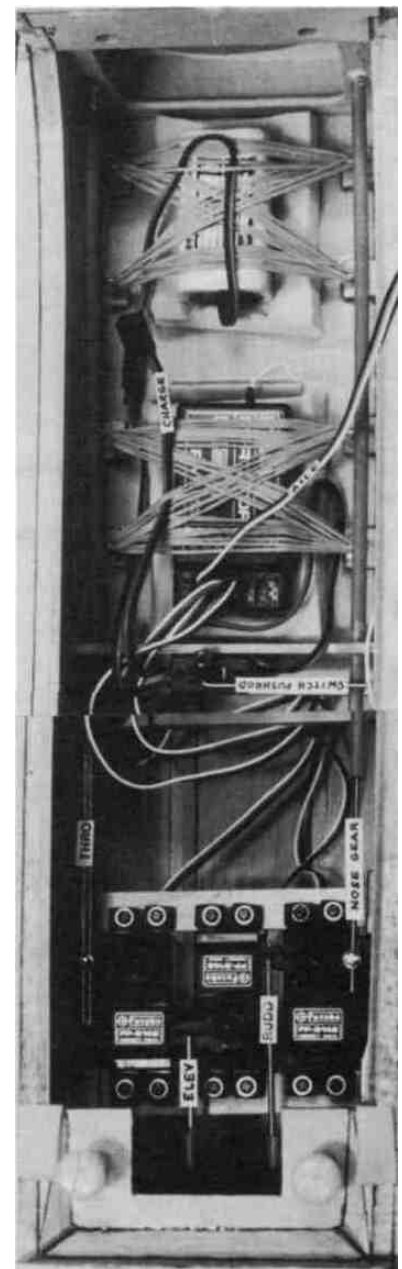

**We recommend the following CONTROL SURFACE THROWS:**

**NOTE:** Throws are measured at the **widest part** of the elevator and rudder.

<b>ELEVATOR:</b>	(High Rate) ... .5/8" up	5/8" down
	(Low Rate) ... .3/8" up	3/8" down
<b>RUDDER:</b>	(High Rate) ... .1-1/2" right	1-1/2" left
	(Low Rate) ... .7/8" right	7/8" left
<b>AILERONS:</b>	(High Rate) ... .5/16" up	5/16" down
	(Low Rate) ... .3/16" up	3/16" down

**NOTE:** If your radio does not have "dual rates", then set up the control surfaces to move at the **high rate** throws.

- 19. Securely anchor the pushrod guide tubes to F-4 using cross-braces cut from scrap 1/8" balsa.
- 20. Attach the throttle pushrod (and nose gear steering pushrod) to the throttle and rudder servo arms. **NOTE:** We recommend using DuBro "E-Z connectors" (or similar) for these hookups, for ease of installation and adjustment.
- 21. If you are using retracts, install your retract servo at this time.
- 22. Hook up your radio system and test the operation of all controls.

## FINISHING

### ADDITIONAL FUELPROOFING

If you have not already done so, make sure the entire engine compartment is completely fuelproof. Also fuelproof any wood that will not be covered and which may be exposed to glow fuel residue, such as the landing gear block slots and the wing saddle. Use epoxy thinned with alcohol, polyester finishing resin or fuelproof paint.

### SEAL OFF COCKPIT

If you leave any openings through the fuse top into the cockpit area, there is the possibility of getting dust on the inside of the canopy, which is almost impossible to remove. Therefore, you should seal all openings to the inside of the cockpit, and paint all exposed balsa to prevent loose wood particles.

### PREPARE THE CANOPY

**NOTICE:** The clear canopy in this kit may have a thin blue protective film on both sides. **Peel off this blue film before attempting to tint or glue the canopy.**

**NOTE:** Some modelers prefer to tint their canopies for a more subtle and realistic effect. You may tint your canopy by immersing it in a concentrated mixture of Rit Liquid Dye and hot tap water. The colors blue, black, brown and dark green work well. Remove the canopy after 5 minutes and rinse it off to check the amount of tint. The hotter the water and the longer you leave it in the dye solution the darker it will tint. **CAUTION:** Do not heat the dye water above tap water temperature, as this could deform the canopy.

- 1. Using a scissors, carefully cut the **canopy** just below the **trim line**.



- 2. **Trial fit** the canopy onto the fuse, pressing into place. Trim as necessary for a good fit. **NOTE:** The trim line on the canopy is approximate. Your canopy trim will vary, depending on how you sanded the fuselage. It may be necessary to do some additional sanding of the fuse near the front of the canopy, if the canopy does not fit properly.

- 3. Sand the edges of the canopy with 320 grit sandpaper. It is important that the canopy does not have any cracks along the edges, as the engine vibration could cause them to **spread**.

**NOTE:** Do not glue the canopy in place until after you have covered your model.

### BALANCE THE AIRPLANE Laterally

**SPECIAL NOTE:** Do not confuse this procedure with "checking the C.G." or "balancing the airplane fore and aft". That very important step will be covered later in the manual.

Now that you have the basic airframe nearly completed, this is a good time to balance the airplane **laterally** (side-to-side). Here is how to do it:

- 1. Temporarily attach the wing and engine (with muffler) to the fuselage.
- 2. With the wing level, lift the model by the engine propeller shaft and the bottom of the rudder (this may require two people). Do this several times.
- 3. If one wing always drops when you lift, it means that side is heavy. Balance the airplane by gluing weight to the other wing tip. **NOTE: An airplane that has been laterally balanced will track better in loops and other maneuvers.**

## FINAL SANDING

Check over the entire structure carefully, inspecting for any poorly glued joints, gaps and "dings". Apply additional glue and/or balsa filler as necessary, then sand the entire fuselage and wing smooth using progressively finer grades of sandpaper.

## COVERING

Because it is assumed that you have had some previous model building experience, we won't go into detail in regard to the covering procedure. Follow the instructions included with your covering material.

**NOTE:** When covering the fin and stab, begin by applying 1/2" wide strips of covering in the corners between the fin and the fairing block, between the stab and the fairing block, and (on the bottom of the stab) between the stab and the fuse sides. Next cover the fairing blocks with pre-cut pieces of covering. Finally, cover the stab and fin with pre-cut pieces that have a straight edge to overlap (1/8" + overlap) the strips you previously applied. **DO NOT, under any circumstances, attempt to cut the covering material after it has been applied to the fin and stab, except around the leading and trailing edges and the tip.** Modelers who do this often cut through the covering and pan-way into the balsa stab. This can weaken the stab to the point where it may fail in flight!

### Recommended Covering Sequence:

1. Strips as described in above **note**
2. Rudder left side
3. Rudder right side
4. Bottom of elevators
5. Top of elevators
6. Stab bottom

7. Stab top
8. Fuse bottom
9. Wing fillets\*
10. Fuse sides
11. Fuse top
12. Fin left side
13. Fin right side
14. Ends of ailerons
15. Bottom of ailerons
16. Top of ailerons
17. Aileron openings in wing
18. Wing fairings (on bottom of wing)
19. Bottom of left wing panel
20. Bottom of right wing panel
21. Top of left wing panel (overlap covering 1/4" at wing LE)
22. Top of right wing panel (overlap covering 1/2" at the center and 1/4" at the LE)

**\*When covering concave surfaces, follow the iron with a damp cloth, pressing the covering down.**

## GLUE THE HINGES

- 1. Lay the rudder, elevators and ailerons on the plans and mark on the leading edge of each part the locations of the hinges, torque rods (and tailgear if you have built a tail-dragger). Now use a sharp Xacto knife to cut slits in the covering at the hinge locations. Trial fit the hinges to make sure you have "found" the slots which you previously cut. In the same manner, slit the covering at the hinge locations in the wing, stab and fin TE. Also cut the covering away from the torque rod and tailgear slots.

**IMPORTANT** - Use coarse sandpaper to roughen both sides of the hinges for a good glue bond.

**NOTE:** When gluing in the nylon tailgear bearing and the hinges, do not just smear glue on the hinge and push it into the slot, as most of the glue will be wiped off as it is being pushed in. You must also work some glue into the slot. A good way of doing this is to scoop up some epoxy with a plastic soda straw, then pinch the end of the straw, insert it into the hinge slot, and squeeze the straw to force glue into the slot. Apply epoxy to the hinge, then insert the hinge into the slot. We recommend 30 minute epoxy for this process. After pushing in the hinge, **wipe away all excess glue with a tissue dampened with rubbing alcohol.**

- 2. Glue the hinges (and tailgear bearing) into the slots in the wing, stab and fin TE using the above process and **allow the glue to harden before proceeding.**

3. Put epoxy into the slots in the elevators and on the corresponding hinges, then push the elevators onto the hinges and wipe away **all** excess epoxy with a tissue (for best results dampen the tissue with rubbing alcohol).

4. Using coarse sandpaper, roughen the part of the aileron torque rods that will be glued into the ailerons, then clean off the sanded portion of the rods with alcohol or a degreasing solvent. Roughen and clean the tailgear wire in the same manner. Using a toothpick, apply a small amount of Vaseline where the torque rods and tailgear wire enter the nylon bearing tubes (to prevent glue from getting inside and locking them up).

5. Put epoxy into the rudder hinge slots (and the tailgear hole), push the rudder into place and **wipe off all excess epoxy**.

6. Put epoxy into the aileron hinge slots and the torque rod holes, push the ailerons into place and wipe off all excess epoxy.

## INSTALL PILOT

Assemble and paint your pilot figure, and glue it to the cockpit floor. **NOTE:** To avoid the possibility of the pilot coming loose inside the canopy, we recommend that you drill up through the cockpit floor and pilot base, and use two #6 or #8 sheet metal screws (not included) to lock the pilot in place.

## GLUE CANOPY IN PLACE



1. Lightly sand the inside of the canopy around the edge (sand a strip approximately 1/8" wide). **NOTE:** To avoid sanding more than you want, it is helpful to first apply

strips of masking tape on the inside of the canopy, 1/8" in from the edges.

2. Poke **pinholes** (1/8" apart) through the covering material in the area where the canopy will be glued to the fuselage.

3. Hold the canopy in place on the fuselage and very carefully apply medium viscosity CA glue around the edges. To control the amount of CA, it is very helpful to use the small diameter teflon applicator tubing which is supplied with most **CA** glues, or use a "Z-End" applicator tip.

4. To hide the canopy glue joint, you can use 1/4" wide Striping tape as a border around the canopy.

## WING SEATING

1. Apply 1/4" or 3/8" wide foam **wing seating tape** to the wing saddle area to seal the wing/fuse joints.\*

2. Also apply a couple pieces of the foam tape to the 1/4" ply wing hold-down plate, which helps to distribute the load when the nylon bolts are tightened.

**\*NOTE:** An alternate method of sealing the wing/fuse joint is to use "silicone bathtub sealer". This is an excellent method, used by many experts because it results in a permanent and nearly perfect wing saddle joint. Briefly, the technique is as follows: 1. Cover the top of the wing center section with waxed paper or plastic kitchen wrap. Pull out all wrinkles and tape it to the wing. 2. Squeeze out a bead of silicone sealer onto the wing saddle area of the fuselage. 3. Lay the wing in the saddle and push down gently. The excess silicone sealer will squeeze out. 4. Allow to dry without disturbing for at least 24 hours. 5. Remove the tape, then remove the wing from the saddle (leaving the waxed paper or plastic wrap in place). 6. Gently pull the waxed paper or plastic wrap away from the sealer. 7. Using a new single-edge razor blade, trim the sealer flush with the wing fillets, and along the inside of the fuselage.

## RE-INSTALL ENGINE & RADIO

Re-install the engine, propeller, battery, receiver, servos, control horns, pushrods, main LG, nose gear and **wheels**. Attach the wing to the fuselage.

## BALANCE YOUR MODEL

**NOTE: This section is VERY important and must not be omitted!** A model that is not properly balanced will be unstable and possibly unflyable.

1. Accurately mark the balance point on the bottom of the wing on both sides of the fairing. The balance point is shown on the plan (CG), and is located approximately 4-3/8 inches back from the leading edge. This is the balance point at which your model should balance for your first flights. Later, you may wish to experiment by shifting the balance up to 3/8" **forward or back** to change the flying characteristics. Moving the balance **forward** may improve the smoothness and arrow-like tracking, but it may then require more speed for takeoff and make it more difficult to slow down for landing. Moving the balance **aft** makes the model more agile with a lighter and snappier "feel" and often improves knife-edge capabilities. In any case, **do not balance your model outside the recommended range.**

2. With the wing attached to the fuselage, all parts of the model installed (ready to fly), and an **empty** fuel tank, block up the tail as necessary to level the fuselage. (If you have built a tricycle gear, the fuse should already be sitting level).

3. Lift the model at the CG marks. If the tail drops when you lift, the model is "tail heavy" and you must add weight to the nose to balance. If the nose drops, it is "nose heavy" and you must add weight to the tail to balance. **NOTE:** Nose weight may be easily installed by using a Prather "Spinner Weight" (available in assorted weights, up to 2 ounces), or by gluing strips of lead into the engine compartment under the engine. Tail weight may be added by using Prather "slick-on" lead weights, and, later, if the balance proves to be OK you can open the fuse bottom and glue these in permanently. **NOTE:** Try shifting the location of the radio components to balance the airplane, before actually adding weight

## FINAL HOOKUPS AND CHECKS

1. Make sure the control surfaces move in the proper direction as illustrated in the sketch at the top of the next column.

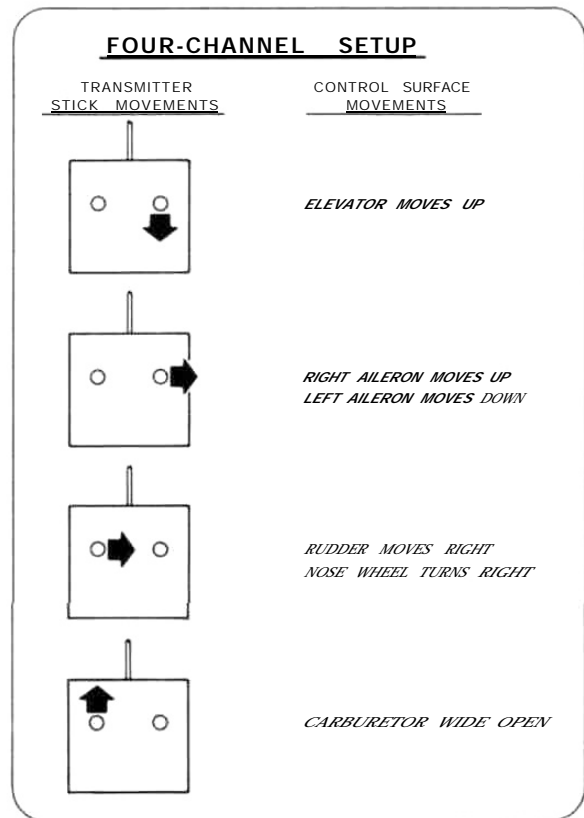

2. Adjust your pushrod hookups as necessary to provide the proper control surface movements as listed on Page 35.

**\*NOTE:** These control surface "throws" are approximate and provide a good starting point for the first flights with your Ultra Sport 60. You may wish to change the throws slightly to provide the smoothness or quickness that you prefer.

3. Check for wing twist as follows:

**NOTE:** Even if you have built your wing on a perfectly flat surface and used utmost care, it is possible that your wing may have a twist due to uneven shrinking of the covering material. **You must check for this condition and correct it before the first flight.**

If you do not own a **wing incidence meter**, we recommend that you purchase one from your local hobby dealer or borrow one from another modeler. With the wing mounted to the fuselage, use the incidence meter to check the angle of your wing at the root and at the tips. If the incidence meter reveals a wing twist of more than 1/4 degree, you must grasp the wing at the tip and twist it slightly, while reheating the covering material. Keep checking, twisting and reheating until the wing twist is removed. **NOTE:** If you have corrected a wing twist by this method, you should periodically re-check to make sure the correction has held.

# PRE-FLIGHT

## CHARGE THE BATTERIES

Follow the battery charging procedures in your radio instruction manual. You should always charge your transmitter and receiver batteries the night before you go flying, and at other times as recommended by the radio manufacturer.

## FIND A SAFE PLACE TO FLY

The best place to fly your R/C model is an AMA (Academy of Model Aeronautics) chartered club field. Ask your hobby shop dealer if there is such a club in your area and join. Club fields are set up for R/C flying which makes your outing safer and more enjoyable. The AMA can also tell you the name of a club in your area. We recommend that you join AMA and a local club so you can have a safe place to fly and also have insurance to cover you in case of a flying accident. (The AMA address is listed on the front cover of this instruction book).

If a club and its flying site are not available, you need to find a large, grassy area at least 6 miles away from any other R/C radio operation like R/C boats and R/C cars and away from houses, buildings and streets. A schoolyard may look inviting but it is too close to people, power lines and possible radio interference.

## GROUND CHECK THE MODEL

If you are not thoroughly familiar with the operation of R/C models, ask an experienced modeler to check to see that you have the radio installed correctly and that all the control surfaces do what they are supposed to. The engine operation must also be checked and the engine "broken in" on the ground by running the engine for at least two tanks of fuel. **Follow the engine manufacturer's recommendations for break-in.** Check to make sure all screws remain tight, that the hinges are secure and that the prop is on tight

## RANGE CHECK YOUR RADIO

Wherever you do fly, you need to check the operation of the radio before every time you fly. This means with the transmitter antenna collapsed and the receiver and transmitter on, you should be able to walk at least 100 feet away from

the model and still have control. Have someone help you. Have them stand by your model and, while you work the controls, tell you what the various control surfaces are doing.

Repeat this test **with the engine running** at various speeds with an assistant holding the model. If the control surfaces are not acting correctly at all times, **do not fly!** Find and correct the problem first.

## ENGINE SAFETY PRECAUTIONS

**NOTE: Failure to follow these safety precautions may result in severe injury to yourself and others.**

Keep all engine fuel in a safe place, away from high heat, sparks or flames, as fuel is very flammable. Do not smoke near the engine or fuel; remember that the engine exhaust gives off a great deal of deadly carbon monoxide. Therefore **do not run the engine in a closed room or garage.**

Get help from an experienced pilot when learning to operate engines.

Use safety glasses when starting or running engines.

**Do not** run the engine in an area of loose gravel or sand; as the propeller may throw such material in your face or eyes.

Keep your face and body as well as all spectators away from the plane of rotation of the propeller as you start and run the engine.

Keep items such as these away from the prop: loose clothing, shirt sleeves, ties, scarfs, long hair or loose objects (pencils, screw drivers) that may fall out of shirt or jacket pockets into the prop.

Use a "chicken stick" device or electric starter; follow instructions supplied with the starter or stick. Make certain the glow plug clip or connector is secure so that it will not pop off or otherwise get into the running propeller.

Make all engine adjustments from **behind** the rotating propeller.

The engine gets hot! Do not touch it during or after operation. Make sure fuel lines are in good condition so fuel is not leaked onto a hot engine causing a fire.

To stop the engine, cut off the fuel supply by closing off the fuel line or follow the engine manufacturer's recommendations. Do not use hands, fingers or any body part to try to stop the engine. Do not throw anything into the prop of a running engine.

# AMA SAFETY CODE

Read and abide by the following Academy of Model Aeronautics Official Safety Code:

## GENERAL

1. I will not fly my model aircraft in competition or in the presence of spectators until it has been proven to be airworthy by having been previously successfully flight tested.
2. I will not fly my model aircraft higher than approximately 400 feet within 3 miles of an airport without notifying the airport operator. I will give right of way to, and avoid flying in the proximity of full scale aircraft. Where necessary an observer shall be utilized to supervise flying to avoid having models fly in the proximity of full scale aircraft
3. Where established, I will abide by the safety rules for the flying site I use, and I will not willfully and deliberately fly my models in a careless, reckless and/or dangerous manner.

## RADIO CONTROL

1. I will have completed a successful radio equipment ground check before the first flight of a new or repaired model.
2. I will not fly my model aircraft in the presence of spectators until I become a qualified flyer, unless assisted by an experienced helper.
3. I will perform my initial turn after takeoff away from the pit, spectator and parking areas, and I will not thereafter perform maneuvers, flights of any sort or landing approaches over a pit, spectator or parking area.

## FLYING

The ULTRA SPORT 60 is a great Flying sport airplane that flies smoothly and predictably, yet is highly maneuverable. It does not have the self-recovery characteristics of a primary trainer, therefore you must either have mastered the basics of R/C flying or seek the assistance of a competent R/C pilot to help you with your first flights.

**TAKEOFF:** If you have dual rates on your transmitter, set the switches to "high rate" for takeoff, especially when taking off in a crosswind. Although the ULTRA SPORT 60 has great low speed characteristics, you should always build up as much speed as your runway will permit before lifting off, as this will give you a safety margin in case of a "flame-out". If you have built a tricycle gear configuration and the ground handling seems too quick and "squirrely," this can be easily fixed by reducing the amount of nose gear steering throw.

**FLYING:** We recommend that you take it easy with your ULTRA SPORT 60 for the first several flights and gradually "get acquainted" with this fantastic ship as your engine gets fully broken-in. Add and practice one maneuver at a time, learning how she behaves in each one. For ultra-smooth flying and normal maneuvers, we recommend using the "low rate" settings as listed on page 35. "High rate" elevator and rudder may be required for crisp snap rolls and spins. "Low rate" rudder is best for knife edge. If you notice any "sluggishness" in the way your ULTRA SPORT 60 handles, it is probably a result of not enough speed, in which case you should install a propeller with increased pitch. Do not exceed the recommended "high rate" throws for the rudder, as this will only result in pitch-down when full rudder is applied. Speed is the key to good knife-edge performance.

**CAUTION (THIS APPLIES TO ALL R/C AIRPLANES):** If, while flying, you notice any unusual sounds, such as a low-pitched "buzz", this may be an indication of control surface "flutter". Because flutter can quickly destroy components of your airplane, any time you detect flutter you must **immediately** cut the throttle and land the airplane! Check all servo grommets for deterioration (this will indicate which surface fluttered), and make sure all pushrod linkages are slop-free. If it fluttered once, it will probably flutter again under similar circumstances unless you can eliminate the slop or flexing in the linkages. Here are some things which can result in flutter: Excessive hinge gap; Not mounting control horns solidly; Sloppy fit of clevis pin in horn; Elasticity present in flexible plastic pushrods; Side-play of pushrod in guide tube caused by tight bends; Sloppy fit of Z-bend in servo arm; Insufficient glue used when gluing in the elevator joiner wire or aileron torque rod; Excessive flexing of aileron, caused by using too soft balsa aileron; Excessive "play" or "backlash" in servo gears; and Insecure servo mounting.

**LANDING:** When it's time to land, make your approach low and shallow, as this ship wants to just keep on flying (especially if built light). If you find that it lands a little fast, you might try dialing in a few clicks of up elevator when you cut

the throttle on the downwind leg of the landing approach. This will automatically help to bleed off some of the speed. If your ULTRA SPORT 60 is built straight and true, you'll find that you can really flare it out for slow, nose-high, full-stall landings without fear of tip stalling.

**Have a ball! But always stay in control and fly in a safe manner.**

## GOOD LUCK AND GREAT FLYING!

SEE THE FULL LINE OF GREAT PLANES  
AIRPLANES AND ACCESSORIES AT YOUR  
HOBBY DEALER.

WE HOPE YOU WILL SELECT ANOTHER  
"GREAT PLANE" AS YOUR NEXT PROJECT.  
THANK YOU!

## FLIGHT TRIMMING

... A model is not a static object. Unlike a car, which can only hunt left or right on the road (technically, a car does yaw in corners, and pitches when the brakes are applied), a plane moves through that fluid we call air in all directions simultaneously. The plane may look like it's going forward, but it could also be yawing slightly, slipping a little and simultaneously climbing or diving a bit! The controls interact. Yaw can be a rudder problem, a lateral balance problem or an aileron rigging problem. We must make many flights, with minor changes between each, to isolate and finally correct the problem.

The chart accompanying this article is intended to serve as a handy field reference when trimming your model. Laminate it in plastic and keep it in your flight box. You just might have need to consult it at the next contest! The chart is somewhat self-explanatory, but we will briefly run through the primary points.

First, we are assuming that the model has been C.G. balanced according to the manufacturer's directions. There's nothing sacred about that spot - frankly, it only reflects the balance point where a prototype model handled the way the guy who designed it thought it should. If your model's wing has a degree more or less of incidence, then the whole balance formula is incorrect for you. But, it's a good ballpark place to start

The second assumption is that the model has been balanced laterally. Wrap a strong string or monofilament around the prop shaft behind the spinner, then tie the other end to the tail wheel or to a screw driven into the bottom of the aft fuse. Make the string into a bridle harness and suspend the entire model inverted (yes, with the wing on!). If the right wing always drops, sink some screws or lead into the left wing tip, etc. You may be surprised to find out how much lead is needed.

At this point the model is statically trimmed. It's only a starting point, so don't be surprised if you wind up changing it all. One other critical feature is that the ailerons must have their hinge gap sealed. If shoving some Scotch tape or Monokote into the hinge gap to prevent the air from slipping from the top of the wing to the bottom, and vice-versa, bothers you, then don't do it.

To achieve the maximum lateral trim on the model, the hinge gap on the ailerons should be sealed. The easiest way to do this is to disconnect the aileron linkages, and fold the ailerons as far over the top of the wing as possible (assuming they are top or center hinged). Apply a strip of clear tape along the joint line. When the aileron is returned to neutral, the tape will be invisible, and the gap will be effectively sealed. Depending on how big the ailerons are, and how large a gaping gap you normally leave when you install hinges, you could experience a 20 percent increase in aileron control response just by this simple measure.

... Your first flights should be to ascertain control centering and control feel. Does the elevator always come back to neutral after a 180-degree turn or Split-S? Do the ailerons tend to hunt a little after a rolling maneuver? Put the plane through its paces. Control centering is either a mechanical thing (binding servos, stiff linkages, etc.), an electronic thing (bad servo resolution or dead-band in the radio system), or C.G. (aft Center of Gravity will make the plane wander a bit). The last possibility will be obvious, but don't continue the testing until you have isolated the problem and corrected it.

... let's get down to the task of trimming the model. Use the tachometer every time you start the engine, to insure consistent results. These trim flights must be done in calm weather. Any wind will only make the model weathervane. Each "maneuver" on the list assumes that you will enter it dead straight-and-level. The wings must be perfectly flat, or else the maneuver will not be correct and you'll get a wrong interpretation. That's where your observer comes in. Instruct him to be especially watchful of the wings as you enter the maneuvers.

Do all maneuvers at full throttle. The only deviation from this is if the plane will be routinely flown through maneuvers at a different power setting...

Let's commence with the "engine thrust angle" on the chart. Note that the observations you make can also be caused by the C.G., so be prepared to change both to see which gives the desired result. Set up a straight-and-level pass. The model should be almost hands-off. Without touching any other control on the transmitter, suddenly chop the throttle. Did the nose drop? When you add power again, did the nose pitch up a bit? If so, you need some downthrust, or nose weight. When the thrust is correct, the model should continue along the same flight path for at least a dozen plane lengths before gravity starts to naturally bring it down.

Do each maneuver several times, to make sure that you are getting a proper diagnosis. Often, a gust, an accidental nudge on the controls, or just a poor maneuver entry can mislead you. The thrust adjustments are a real pain to make. On most models, it means taking the engine out, adding shims, then reassembling the whole thing. Don't take shortcuts. Don't try to proceed with the other trim adjustments until you have the thrust line and/or C.G. correct. They are the basis upon which all other trim settings are made.

Also, while you have landed, take the time to crank the clevises until the transmitter trims are at neutral. Don't leave the airplane so that the transmitter has some odd-ball combination of trim settings. One bump of the transmitter and you have lost everything. The trim must be repeatable, and the only sure way to do this is to always start with the transmitter control trims at the middle.

The next maneuver is somewhat more tricky than it looks. To verify the C.G., we roll the model up to a 45-degree bank, then take our hands off the controls. The model should go a reasonable distance with the fuse at an even keel. If the nose pitches down, remove some nose weight, and the opposite if the nose pitches up. The trick is to use only the ailerons to get the model up at a 45-degree bank. We almost automatically start feeding in elevator, but that's a no-no. Do the bank in both directions, just to make sure that you are getting an accurate reading of the longitudinal balance.

We now want to test the correct alignment of both sides of the elevator (even if they aren't split, like a Pattern ship's, they can still be warped or twisted). Yaw and lateral balance will also come into play here, so be patient and eliminate the variables, one-by-one. The maneuver is a simple loop, but it must be entered with the wings perfectly level. Position the maneuver so that your assistant can observe it end-on. Always loop into the wind. Do several loops, and see if the same symptom persists. Note if the model loses heading on the front or back side of the loop. If you lose it on the way up, it's probably an aileron problem, while a loss of heading on the way back down is most likely a rudder situation.

After you get the inside loops going correctly, do the same maneuver to the outside, entering from an inverted position . . . Before you make too many dramatic changes, glance at the remainder of the chart and note the myriad combination of things we can do just with the ailerons. Each

change you make will affect all other variables!

Note that the Yaw test is the same looping sequences. Here, however, we are altering rudder and ailerons, instead of the elevator halves. We must repeat that many airplanes just will not achieve adequate lateral trim without sealing the hinge gaps shut. The larger you make the loops (to a point), the more discernable the errors will be.

The Lateral Balance test has us pulling those loops very tightly. Actually, we prefer the Hammerhead as a better test for a heavy wing. Pull straight up into a vertical and watch which wing drops. A true vertical is hard to do, so make sure that your assistant is observing from another vantage point. Note that the engine torque will affect the vertical fall off, as will rudder errors. Even though we balance the wing statically before leaving for the field, we are now trimming it dynamically.

The Aileron Coupling (or rigging) is also tested by doing Hammerheads. This time, however, we want to observe the side view of the model. Does the plane want to tuck under a bit? If so, then try trimming the ailerons down a small bit, **so** that they will act as flaps. If the model tends to want to go over into a loop, then rig both ailerons up a few turns on the clevises. Note that drooping the ailerons will tend to cancel any washout you have in the wing. On some models, the lack of washout can lead to some nasty characteristics at low speeds.

The effects noted with the Aileron Coupling tests can also be caused by an improperly set wing incidence. The better test for this is knife-edge flight . . . If the model tends to pull upward, i.e., it swings toward a nose up direction, then reduce the wing incidence. If the model tries to go off heading toward the bottom side of the plane, then increase incidence.

Again, we reiterate that all of these controls are interactive. When you change the wing incidence, it will influence the way the elevator trim is at a given C.G. Re-trimming the wing will also change the rigging on the ailerons, in effect, and they may have to be readjusted accordingly.

The whole process isn't hard. As a matter of fact it's rather fun - but very time consuming. It's amazing what you will learn about why a plane flies the way it does, and you'll be a better pilot for it. One thing we almost guarantee, is that your planes will be more reliable and predictable when they are properly trimmed out. They will fly more efficiently, and be less prone to doing radical and surprising things. Your contest scores should improve, too.

We wish to acknowledge the Orlando, Florida, club newsletter, from which the basics of the chart presented here were gleaned.

Reprinted in part by Great Planes Model Manufacturing Company, courtesy of Scale R/C Modeler magazine. Pat Potega, Editor, August, 1983 issue.

# FLIGHTTRIMMING CHART

TRIM FEATURE	MANEUVERS	OBSERVATIONS	CORRECTIONS
CONTROL CENTERING	Fly general circles and random maneuvers.	Try for hands off straight and level flight.	Readjust linkages so that Tx trims are centered.
CONTROL THROWS	Random maneuvers.	A. Too sensitive, jerky controls. B. Not sufficient control.	If A, change linkages to reduce throws. If B, increase throws.
ENGINE THRUST ANGLE <sup>1</sup>	From straight flight, chop throttle quickly.	A. Aircraft continues level path for short distance. B. Plane pitches nose up. C. Plane pitches nose down.	If A, thm is okay. If B, decrease downthrust. If C, increase downthrust.
CENTER OF GRAVITY LONGITUDINAL BALANCE	From level flight roll to 45-degree bank and neutralize controls.	A. Continues in bank for moderate distance. B. Nose pitches up. C. Nose drops.	If A, trim is good. If B, add nose weight. If C, remove nose weight.
SPLIT ELEVATORS (Also Yaw and C.G.)	Into wind, pull open loops, using only elevator. Repeat tests doing outside loops to inverted entry.	A. Wings are level throughout. B. Plane tends toward outside when right side up, and to inside when inverted. C. Plane goes in on regular loops, and out on inverted. D. Plane goes out on both types of loops. E. Plane goes in on both types of loops.	If A, trim is fine. If B, add weight to right wing, or add right rudder. If C, add weight to left wing, or add left rudder. If D, raise right half of elevator (or lower left). If E, raise left half of elevator (or lower right).
YAW <sup>2</sup>	Into wind, do open loops, using only elevator. Repeat tests doing outside loops from inverted entry.	A. Wings are level throughout. B. Yaws to right in both inside and outside loops. C. Yaws to left in both inside and outside loops. D. Yaws right on insides, and left on outside loops. E. Yaws left on insides, and right on outside loops.	If A, trim is correct. If B, add left rudder trim. If C, add right rudder trim. If D, add left aileron trim. If E, add right aileron trim.
LATERAL BALANCE	Into wind, do tight inside loops, or make straight up climbs into Hammerheads. Do same from inverted entry.	A. Wings are level and plane falls to either side randomly in Hammerhead. B. Falls off to left in both inside and outside loops. Worsens as loops lighten. C. Falls off to right in both loops. Worsens as loops tighten. D. Falls off in opposite directions on inside and outside loops.	If A, trim is correct. If B, add weight to right wing tip. If C, add weight to left wing tip. If D, change aileron trim. <sup>3</sup>
AILERON RIGGING	With wings level, pull to vertical climb and neutralize controls.	A. Climb continues along same path. B. Nose tends to go to inside loop. C. Nose tends to go to outside loop.	If A, trim is correct. If B, raise both ailerons very slightly. If C, lower both ailerons very slightly.
WING INCIDENCE	Knife edge flight.	A. Models tends to veer in nose up direction. B. Model veers in nose down direction.	If A, reduce wing incidence. If B, increase wing incidence.

1. Engine thrust angle and C.G. interact. Check both.

2. Yaw and lateral balance produce similar symptoms. Note that fin may be crooked. Right and left references are from the plane's vantage point.

3. Ailerons cannot always be trimmed without sealing the hinge gap.



## ULTRA SPORT 60 PARTS LIST (Cont.)

### PART# QTY. DESCRIPTION

#### SUB-PACK STAB PARTS (US60A07)

US60S01	1	Balsa 3/8 Shaped Stab Front
US60S02	1	Balsa 3/8 x 3 x 22-9/16 Stab Rear
US60S03	2	Balsa 3/8 Shaped Elevator

#### SUB-PACK SMALL PIECES (US60A08)

DOWEL034	2	Hardwood Dowel 1/4 Dia. x 4-9/16
HRDWD005	2	Small Hardwood L.G. Gusset
US60F05	1	Ply 1/4 F-1 (Firewall)
US60F27	2	Ply 3/16 x 1/2 x 3-5/8 Servo Rail
US60F28	1	Ply 1/4 Shaped Wing Mounting Plate
US60F33	1	Basswood 1/8 x 1/8 x 3-5/8 Spacer
US60W27	2	Bass 7/16 x 5/8 x 6-1/4 Grooved LG Block
US40W28	2	Maple 7/16 x 5/8 x 7/8 Short LG Block
US40W35	6	Ply 1/16 DC Rib Doublers for LG
US60W40	4	Ply 1/4 x 13/16 x 2-11/16 Retract Rail
US60F02	1	Ply 1/16 DC Spinner Ring

#### SIJB.PACK SHORT STICKS (US60A09)

US60F34	1	Balsa Triangle 1/2 x 11-1/2 (Nose Comers)
US60S04	1	Balsa 1/8 x 3/8 x 11-7/8 Elev & Rudd Ends
US60W39	4	Balsa 3/32 x 1 x 13 LE Sheet Front
US60S05	1	Balsa 3/8 x 5/8 x 11 Stab Tips
US60R08	1	Balsa 5/16 x 5/8 x 5-3/4 Fin Tip
US60F21	2	Balsa 1/4 x 1/4 x 10 Cockpit Side
US60F36	1	Balsa 1/4 Shaped Fuse Cross-Brace (at F-4) 1/4 x 1/2 x 3
US60F37	1	Balsa 1/4 Shaped Fuse Cross-Brace (at F-5) 1/4 x 1/2 x 2-9/32

### PART# QTY. DESCRIPTION

#### SUB-PACK FIN/RUDDER PARTS (US60A10)

US60R02	1	Balsa 5/16 Shaped Fin Front
US60R03	1	Balsa 5/16 Shaped Fin Rear
US60R04	1	Balsa 5/16 Shaped Rudder Front
US60R05	1	Balsa 5/16 Shaped Rudder Rear

#### SUB-PACK HARDWARE (US60M01)

GLTP011	1	Fiberglass Tape 4" x 28-1/2"
NUTS003	4	6-32 Blind Nut
NYLON02	2	Nylon Control Horn
NYLON09	2	Nylon Hinges (12 per tree)
NYLON16	1	Nylon Steering Arm
NYLON17	4	Nylon Clevis
NYLON20	2	Nylon Aileron Clevis Connector
NYLON21	2	Nylon Aileron Clevis
NYLON36	1	Nylon LG Strap (4 per tree)
PLTB004	1	Plastic Inner Pushrod Tube 6-1/2"
SCRW002	4	2-56 x 5/8" Machine Screw
SCRW005	1	6-32 x 1/8" Socket Set Screw
SCRW020	1	6-32 x 1/4" Machine Screw
SCRW024	8	#2 x 3/8" Sheet Metal Screw
SCRW033	4	6-32 x 3/4" Machine Screw
SCRW042	4	#6X1" Sheet Metal Screw
WHCL005	2	5/32" Wheel Collar (For nose gear & steering arm)
WBNT002	1	Aileron Torque Rod Set (Lt & Rt)
WBNT128	1	3/32" Tail Gear Wire & Bearing
WBNT149	1	5/32" Wire Nose Gear
WBNT150	2	5/32" Wire Main Gear
WBNT145	1	1/8" Wire Elevator Joiner

# 2-VIEW DRAWING

USE THIS FOR PLANNING YOUR TRIM SCHEME.

