

TRI-STAR



**BUILDING
and FLYING
INSTRUCTION
MANUAL**



KIT #RC-70

Designed By: *LeRoy Satterlee*

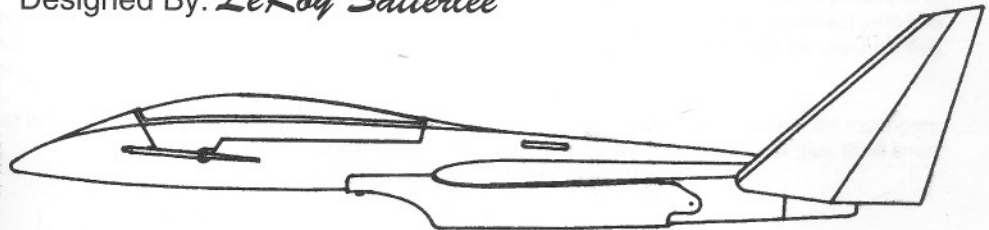

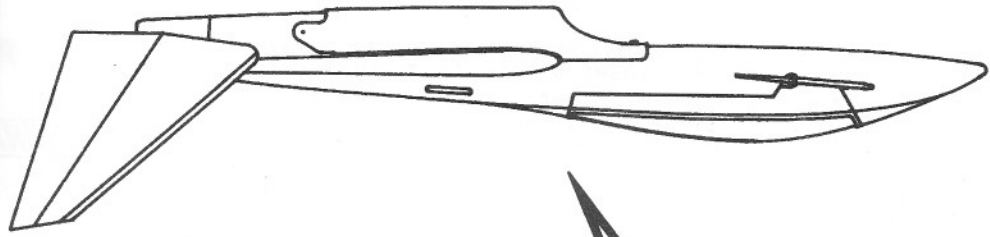

TRI-STAR



**BUILDING
and FLYING
INSTRUCTION
MANUAL**



KIT #RC-70

Designed By: *LeRoy Satterlee*

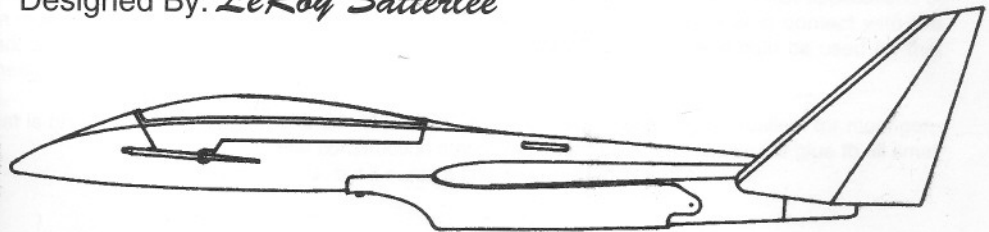

THE SIG TRI-STAR



1. WHY AN ELECTRIC ?

In the larger metropolitan areas, finding, and keeping, flying sites is getting more and more difficult. Housing development, noise regulations, sports complexes, all fuel the battle for use of available recreational space. An electric Tri- Star can be flown in any local schoolyard or park (be sure to check your local regulations) without most people even knowing it's there. Performance of any electric airplane is the result of careful matching of the battery/motor/propeller combination. Feel free to use any combination you choose, or, **SIG MFG.** can offer you a tested electric drive system combination.

This is packaged as a "Sig Electric Flight Accessory Pack." and will be available through your authorized SIG dealer.

2. WHY A CANARD ?

Canards have a unique look that can be distinguished from anything else in the sky, and contrary to some stories, are quite stable. They resist stalling more than other aircraft designs, but are still quite aerobatic.

3. WHY LASER CUTTING ?

Laser cutting offers some wonderful advances for model designers, and model builders. Wherever it was practical we employed laser cutting in this kit. You will find some saw cut parts in the kit. Saw cutting is used where economics makes better sense to do so.

The accuracy of laser cutting, when compared to traditional die cutting, allows you to build a straighter model the first time. Most parts require very little, if any, sanding, but it is best if you lightly sand away the blackened edge on the ply parts for better glue adhesion. Laser cutting means less work for you, and better quality control for us.

GLOW POWER.

Tri- Star makes a delightful glow powered airplane, and has been tested with engines in the .09 to .15 sizes.

There are some engine size limitations however.

ENGINES LARGER THAN .15 SIZE ARE NOT RECOMMENDED for Tri- Star. The additional weight added to the rear of the airplane can cause a very tail heavy and unstable aircraft. For the safety of yourself, and others. Resist the temptation to install a .40, or even a .25 in your Tri- Star. Remember, Nose heavy airplanes may fly poorly, But, tail heavy airplanes seldom fly at all.

PROPELLERS.

Pusher props are available from a number of manufacturers in sizes compatible with the recommended glow engine sizes. Sig Manufacturing carries a good stock of props in these sizes, so ask your Sig dealer to get them for you, or if you have no Sig dealer near you, you may order directly from us. Pusher props for electrics are easier. All test work on the Tri- Star was done using Tractor props, with the direction of rotation of the electric motors reversed.

SLOPE SOARING.

If you are not into powered flight of any kind, but are hooked on the wonderful sport of slope soaring, we've thought of you too. Tri- Star makes a nifty slope soarer which is very light, and can be flown in light winds. The unique plastic belly pan provides an excellent spot for the addition of ballast for those windier days, so now, you can fly no matter how hard the wind blows.

RADIO EQUIPMENT REQUIREMENTS.

The Tri- Star requires a two, or three channel radio system, depending on the version you choose to build. Both powered versions require elevator, aileron, and throttle. The slope soaring version requires elevator and aileron only. There are no fancy mixers required, and Tri- Star is designed to accept standard size components. No need to go out and buy a mini, or micro radio system.

You **MUST**, in any case, use only a radio system that is on an *aircraft approved frequency*. It is illegal to do otherwise.

IDENTIFYING THE KIT PARTS.

The "PARTS IDENTIFICATION SHEET" in the centerfold of this manual will help you identify the laser cut pieces. Note that there are more than one of some of the parts required. All other parts are identified by the "COMPLETE KIT PARTS LIST", beginning on page 2. Sort the different sizes of sheets and sticks into individual piles to avoid confusion during construction. Cut the longest pieces first, followed by any medium length parts, before cutting any full length strips into short pieces.

NOTE: You will find very little scrap in this kit. This is because laser cutting allows us to get more parts from a sheet of wood, so virtually nothing is wasted.

SANDING BLOCK.

Although the Tri- Star requires a minimum of sanding to the individual parts, it does require some shaping of the fuselage for a nice rounded look, and a smoothing of the finished components before covering.

A good general purpose sanding block can be made by wrapping a 9" x 11" sheet of sandpaper around a piece of wood that is 3/4" x 3" x 11" and is flat. Use three screws, or thumbtacks, along one edge to hold the overlapped ends of the paper to the block. Put 80 grit paper on the block for general construction. Switch to 220 grit or 360 grit for final sanding. In addition to the large block, there are places where a sandpaper "file" will be handy. This can be made by gluing sandpaper to an assortment of small spruce or pine sticks or by wrapping it around a dowel for shaping inside corners.

GLUES.

There are so many different glues available to the modeler today, that it can be confusing to even the most experienced builders. To simplify matters, most glues can be classified as one of four basic types.

1. Fast Cyanoacrylate adhesives (abbreviated in this book as "CA"), such as SIG CA.
2. Water based glues such as SIG- BOND (yellow), and SIG-WELD (white).
3. Super strong (but heavier) two part epoxies such as SIG KWIK-SET (5 minute cure) or SIG EPOXY (3 hour cure).
4. Traditional solvent based glues such as SIG- MENT.

Each of these glues has different characteristics and advantages. Often, the choice of which type to use is strictly a matter of personal preference based on your experience with previous models. CA is recommended as our first choice because of its ability to penetrate an already assembled joint. In other words, the parts can be assembled dry (without glue), the alignment checked and adjusted, and then the glue is applied to the joints. You should also have on hand some epoxy, both 5 minute and slow cure, and some water based glue, as both are called out in several of the construction steps for the Tri- Star.

SIG CA, like most other brands of CA, comes in three different viscosities, thin, medium, and slow. Odorless CA is generally more expensive, and is ideal for those builders who cannot tolerate the fumes from normal CA. Foam friendly CA is called out for several steps in the construction of the Tri- Star, so be sure to have a bottle of it on hand also. **DO NOT USE REGULAR CA ON THE FOAM WING CORES AS IT CAN DISSOLVE THEM.**

Accelerator sprays, and CA debonders are also available and can speed the building process. **DO NOT USE CA ACCELERATORS NEAR THE FOAM WING CORE AS IT MAY DISSOLVE THEM.**

Sig glue characteristics are described below.

SIG CA THIN - Watery in consistency, thin CA should be used when the two parts to be joined are in perfect contact with zero gaps. Capillary action pulls this glue deep into the wood resulting in a very strong bond, and it cures in just a few seconds. Thin CA can be used to tack assemblies together, but these joints should be re-glued later, using medium or thick CA. Thin CA is required for most applications of SIG EASY HINGES, except where the hinge is in contact with the foam wing core. Thin, FOAM FRIENDLY CA should be used for that application.

SIG CA PLUS - Our medium thickness CA is excellent for most general construction steps. The extra thickness allows the glue to fill small gaps, but it cures a little slower than Thin CA.

SIG CA SLOW - This is our thickest formula for filling large gaps and building up fillets at joints requiring extra strength. It cures very slowly, thus allowing the most time for you to position parts during construction. This is especially useful when laminating large sheeted areas, such as fuselage doubler and fuselage side assemblies.

SIG KWIK SHOT ACCELERATOR - Spraying accelerator on CA (any viscosity) will cure it almost instantly. Although CA is the fastest glue available for model building, it's sometimes nice to speed it up even more with accelerator.

SIG DEBONDER - This is used to separate improperly glued parts, but you'll probably use it to un-stick your fingers more than anything else.

CAUTION: Some people have experienced allergic reactions from using CA or EPOXY glues. This is very rare. However, it is always important that such glues, paints, thinners, and solvents, be used with adequate ventilation to carry any fumes away.

COMPLETE KIT PARTS LIST.

LASER-CUT Balsa PARTS

- 2 - 3/32" Balsa; Fuselage Sides
- 1 - 3/32" Balsa; Fuselage Bottom, Front (**FBF**)
- 1 - 3/32" Balsa; Fuselage Bottom, Rear (**FBR**)
- 1 - 3/32" Balsa; Fuselage Top, Front (**FTF**)
- 1 - 3/32" Balsa; Fuselage Top, Rear (**FTR**)
- 2 - 3/32" Balsa; Hatch Sides
- 1 - 3/32" Balsa; Hatch Base
- 1 - 3/32" Balsa; Fuselage Bulkheads, F- 2, F- 3, F- 4, F- 5

LASER-CUT PLY PARTS

- 2 - 1/32" Birch Ply; Fuselage Doubler, Front
- 2 - 1/32" Birch Ply; Fuselage Doubler, Rear
- 2 - 3/32" Birch Ply; F- 1 Bulkheads
- 1 - 3/32" Birch Ply; Firewall
- 1 - 3/32" Birch Ply; Canopy Bulkhead, Front (**CBF**)
- 1 - 3/32" Birch Ply; Canopy Bulkhead, Rear (**CBR**)

SAW-CUT Balsa PARTS

- 1 - 3/16" Balsa; Canard
- 2 - 3/16" Balsa; Elevator Halves
- 2 - 3/16" Balsa; Fin, Front
- 2 - 3/16" Balsa; Fin, Rear

SAW-CUT PLY PARTS

- 2 - 1/16" x 3/8" x 1/2" Ply; Optional hatch
- 3 - 3/16" x 1/2" x 3/4" Birch Ply; Belly Pan Mounts.
- 2 - 3/16" x 3/4" x 2" Birch Ply; Wing Bolt Plates
- 2 - 3/32" x 1/2" x 3/4" Birch Ply; cowl Mounting Tabs.
- 1 - 3/32" x 1- 5/8" x 2" Birch Ply; Main Gear Doubler.
- 1 - 3/32" x 1- 1/16" x 1- 9/16" Birch Ply; Nose Gear Mount.

FOAM

- 1 - White Foam; Wing Core Block (2 Wing Cores)

SHEET Balsa

- 5 - 1/32" X 3" X 30" Balsa; Wing L.E., T.E. & Center Section

SPRUCE STICKS

- 4 - 3/16" X 1/4" X 2" Spruce; Servo Mounting Rails

WOOD DOWELS

- 1 - 1/2" Dia X 7/8" Birch; Wing Bolt, Front
- 1 - 1/2" Dia X 5/8" Birch; Wing Bolt, Rear
- 1 - 1/8" Dia x 1/2" Birch; Hatch Pin, Front

Balsa STICKS

- 1 - 3/16" X 1/4" X 24 Balsa; Fin L.E. (makes two)
- 2 - 1/8" x 1/4" x 30" Balsa; Wing T.E. Spars
- 1 - 1/4" x 1/2" x 30" Balsa; Wing L.E.
- 3 - 1/4" x 30" Balsa Triangle; Fuselage & Hatch reinforcements
- 4 - 1/32" x 1/4" x 30" Balsa; Wing Cap Strips

- 1 - 1/8" x 3/8" x 1 3/4" Balsa; Fuselage Front Crossbrace
- 1 - 5/16" x 5/16" x 7/16" Balsa; Hatch pin block.
- 1 - 3/32" x 1" x 2- 1/8" Balsa; Belly Pan Cross Brace.

SHAPED Balsa PARTS

- 2 - 1/4" X 1- 1/4" X 30" Balsa; Ailerons
- 1 - 1 3/8" x 2" x 3" Balsa; Nose Block
- 1 - 1/4" x 1/2" x 30" Balsa; Grooved Wing L.E., Left Hand side.

PLASTIC PARTS

- 1 - Vacuum Formed ABS; Cowl/Tail Cone
- 1 - Vacuum Formed ABS; Belly Pan
- 1 - Vacuum Formed Clear Plastic; Main Canopy
- 1 - Vacuum Formed Clear Plastic; Canopy Nose Piece
- 1 - Vacuum Formed Clear Plastic; Canopy Tail Piece
- 1 - 1/8" O.D. x 32" Plastic Tube; antenna
- 1 - 1/8" O.D. x 9- 5/8" Plastic Tube; Throttle Cable

MISCELLANEOUS PARTS

- 1 - .060" x 1/2" x 4" Servo Tape; Throttle servo
- 1 - 1/16" X 1/4" X 17" Foam Wing Seat Tape
- 1 - 2" X 18" Fiberglass Tape; Wing Center Joint
- 4 - Decal Sheets; DKM 70A,B,D,E
- 1 - 38" x 50" Plan Sheet (Main Drawing)
- 1 - 17" x 22" Plan Sheet (Landing Gear)
- 1 - Photo Illustrated Instruction Book

HARDWARE

- 1 - Pkg of 15 Easy Hinges; Ailerons & Canard
- 2 - Small Nylon Control Horns; (1 R.H., 1 L.H.)
- 3 - 2- 56 R/C Links; (2 Aileron, 1 Elevator)
- 3 - 2- 56 x 10" Threaded Rod; (2 Aileron, 1 Elevator)
- 1 - 4" Control Horn Assembly.; Canard
- 1 - Solder Link; Throttle
- 5 - Pushrod Connector Assembly.; Aileron, Elevator, Throttle
- 3 - 4- 40 Blind Nut; Belly Pan Mounting
- 3 - 4- 40 Nylon Pan Head Screw; Belly Pan Mounting
- 3 - Brass Eyelets; Belly Pan Mounting
- 6 - #2 x 3/8" Sheet Metal Screws; Firewall & Cowl attaching
- 1 - #10- 32 x 1- 1/4" Nylon Bolt; Front Wing Mount
- 1 - #10- 32 x 1" Nylon Bolt; Rear Wing Mount
- 1 - 1/16" x 12" Steel Flex Cable; Throttle hook up
- 4 - #2- 56 x 1/2" Round Head Screws; Aileron Control Horns
- 12 - #3 (7/64" I.D.) Flat Metal Washers; Landing Gear.
- 1 - #4- 40 x 3/8" Socket Head Screw; Steering Arm & Collar.
- 4 - #2 x 3/8" Sheet Metal Screws; Nose Gear Straps.
- 1 - 3/32" I.D. Wheel Collar; Nose Gear Mounting.
- 1 - #4- 40 size Nylon Aileron Connector; Nose Gear Steering Arm.
- 5 - 3/32" Nylon Landing Gear Clips; Nose & Main Gear Mounting.
- 1 - 3/32" Dia. Nose Gear Wire.
- 1 - 3/32" Dia. Main Gear Wire.
- 6 - #2- 56 x 3/8" Mounting Bolts with Nuts; Main Gear Mounting.
- 1 - 1/16" x 12" Music Wire; Steering link.

NOTES BEFORE BEGINNING CONSTRUCTION.

Any reference to right or left refers to your right or left as if you were seated in the cockpit. Although the Tri- Star is laser cut to carefully controlled tolerances, which reduces the risk of you building a crooked model, you should still begin work on a flat, straight, building board. This is especially important when sheeting the wings. The building board can be a table, workbench, or even a reject "door core" from the lumber yard. Just so it is perfectly flat, and is not twisted. Cover the top surface of the building board with a piece of Celotex type wall board, or the equivalent, into which you can stick pins during construction.

When pinning and gluing parts directly over the full size plans, cover the plans with waxed paper to prevent the parts from becoming glued to the plans sheet.

Don't use a ball point pen for making marks on the model during construction. If not sanded off completely, these ink marks will show through the models final covering or finish. Use a soft pencil instead of a pen.

The Laser cut parts, and the larger saw cut parts are identified on the "Parts Identification Page" in the center fold of this manual. Mark the corresponding parts with a soft pencil, so you'll know what they are as they are required during construction.

When required, always cut the longest pieces needed first, then the next shortest, and so on. That way, you won't get a nasty surprise by finding you've cut a long part required into smaller pieces.

ABOUT THE BUILDING SEQUENCE.

The quickest and most efficient way to build a model is to have a couple of different components under construction at one time. This way, while the glue dries on one part, you can be working on another. However, following the general building sequence used in this manual is best when building the Tri- Star. Wherever you are told to stop work on a certain component, and to go on to another, Please do so. This will keep you from getting too far ahead and doing something out of sequence. In certain steps in the construction of Tri- Star this is very important in order to get it right.

Place a check mark in the box after each construction step is completed. This will help to keep you from losing your place in the sequence as you build. Plan ahead! Read the instruction book completely, and study the plans sheets thoroughly before you begin construction.

ITEMS YOU WILL NEED TO COMPLETE YOUR TRI- STAR.

- A. Radio Control System, Three Channel Minimum.
- B. 2 Rolls of Low Temperature Covering Film.
- C. Adhesives- See the section on Glues in this manual.
- D. A Small bottle of Dope or Paint.
- E. An Electric, or Glow, Power System, with the correct propeller.
- F. A Motor Mount to Match your Glow Engine.
- G. A Fuel Tank (2 oz. Sullivan is shown), but a 4 oz. Sullivan Flex Tank will fit also.
- H. 3M 77™ Spray Adhesive.
- J. 1/2" and 3/16" O.D. x 12" long K & S Brass tubes.
- K. Two 1- 3/4" Diameter Wheels, one 1- 1/2" diameter wheels.
- L. Five 3/32" size Wheel Collars.

WING FIN CONSTRUCTION.

❑ 1. Find the wing fin parts. You should have two fin front halves, and two fin rear halves. The front fin halves are approximately 1" longer than the rear halves.

Cover the plan in the area of the wing fin outline with waxed paper. Pin down the front and rear fin halves over the outline on the plan. Apply a bead of thin CA to the joint between the two parts and allow to cure for a few minutes.

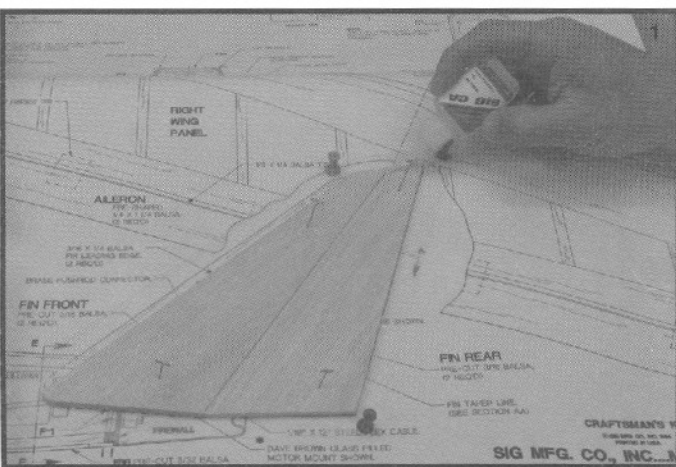

❑ 2. Find the 1/4" x 3/16" x 24" balsa stick that will be used to complete the fin leading edges. Cut it in half. Pin one piece tightly into position against the front surface of the front fin half. Apply a bead of thin CA to the joint and allow to cure for a few minutes.

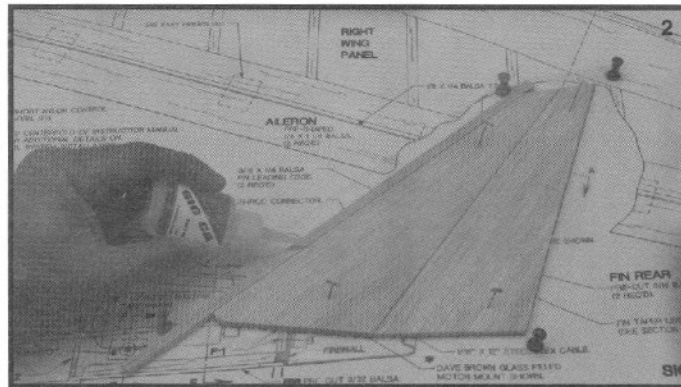

❑ 3. Repeat steps 1, and 2, to create the second wing fin assembly.

❑ 4. Block sand both sides of both wing fin assemblies to remove any irregularities and to obtain a smooth surface. Trim and round off the lower front end of each completed fin, according to the line on the plan.

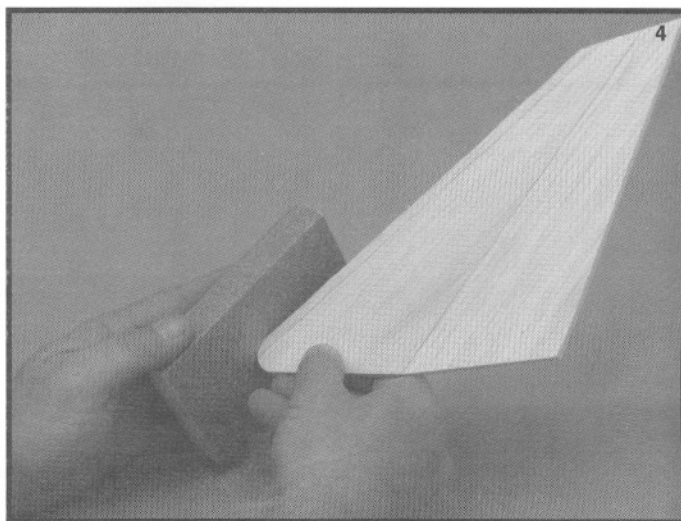

❑ 5. The plan shows a line on the wing fin called a "Fin taper line". See the fuselage side view and section AA on the drawing. This describes how to taper the INNER surface of each wing fin from 3/16" thick to 1/16" thick. This taper creates a slight airfoil shape to the fins. Use a razor plane, and a sanding block to cut the taper. Work carefully and don't get the trailing edge too thin. Be sure you make a right hand and a left hand of these parts. Remember, the taper is cut on the INNER surface of each wing fin.

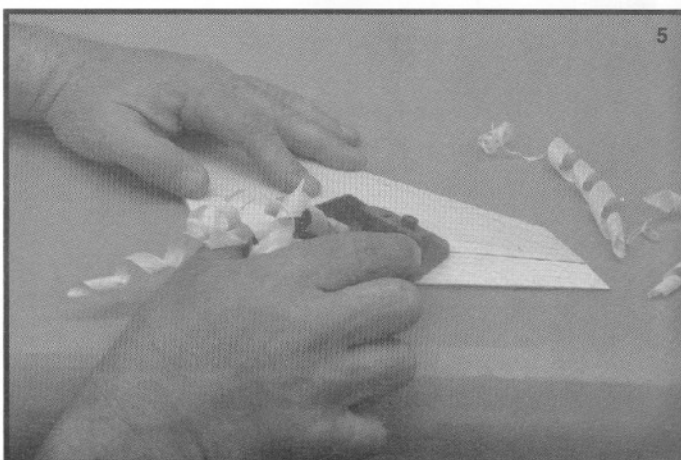

- 6. Finish shaping the fins by sanding all the top, bottom, and leading edges to a nice round shape. Final sand all the surfaces with 220 grit sandpaper for a velvety smooth surface.

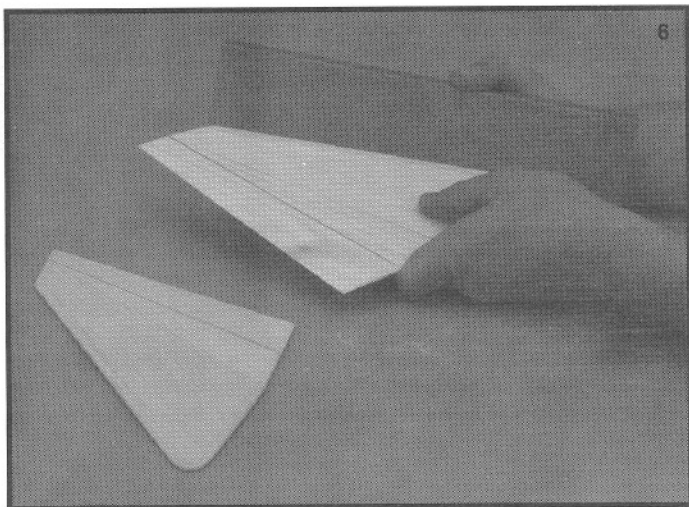

BUILDERS TIP: SHARPEN ONE END OF THE 3/16" O.D. AND THE 1/2" O.D. K&S BRASS TUBES BY SANDING A BEVEL ON THE OUTSIDE AND BY SCRAPING THE INSIDE WITH AN EXACTO KNIFE. THESE MAKE AN EXCELLENT TOOL FOR BORING HOLES IN Balsa, AND WILL BE NEEDED IN THE NEXT STEPS. THESE TUBES ARE NOT FURNISHED IN THE KIT AND WILL HAVE TO BE PURCHASED SEPARATELY.

- 7. In the center section of this manual is a template to help you locate the position of the hole in the left hand wing fin for the antenna tube to exit through. Cut out the template and lay it over the left hand wing fin. Using a 3/16" drill bit, or a sharpened piece of 3/16" O.D. brass tube, carefully cut the hole in the fin. Save the template. It will be used again in a later step. This completes the wing fins except for covering, which will be covered later in this book.

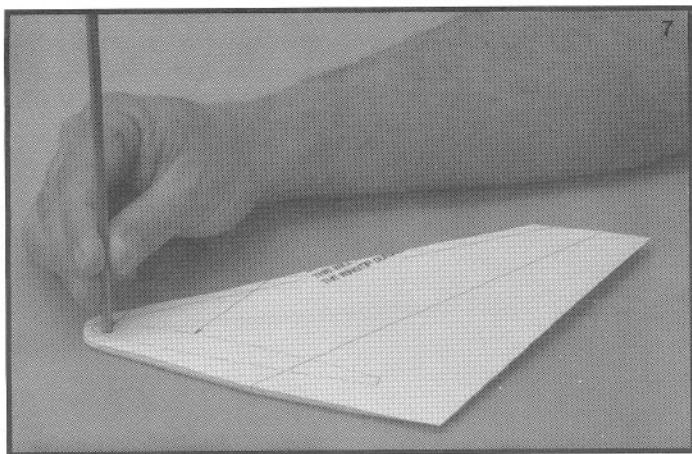

CANARD CONSTRUCTION.

- 8. The canard is actually the horizontal stabilizer of the Tri-Star. The canard fixed surface needs a clearance notch cut into it so that the control horn doesn't rub on it. This notch is shown on the top view of the fuselage. Cut the ends of the notch with the 1/2" o.d. brass tube. Remove the center portion with an Exacto knife. Round the front edges, and the tips of the canard, using a razor plane and a sanding block.

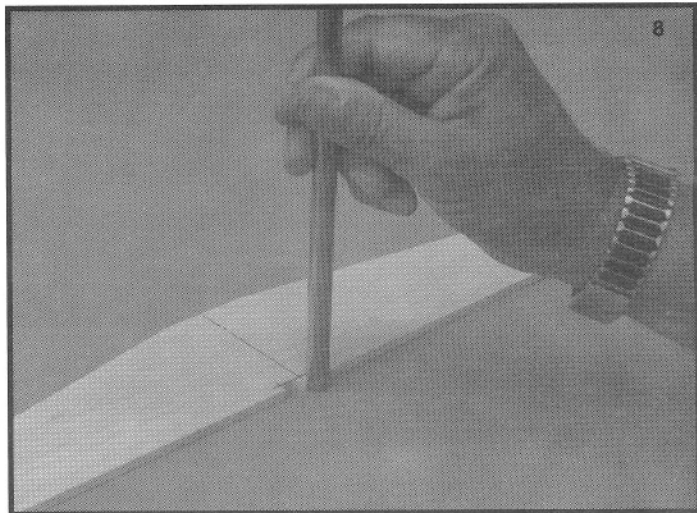

- 9. The inner, rear corners of the moveable elevators require rounding. See the top view of the plan for just how much is removed.

- 10. The Elevators also require drilling for the 4" center mounted control horn. Pin the elevators down over the plan and mark them where the horn enters the front edge of the elevator.

BUILDERS TIP: WRAP A STRIP OF MASKING TAPE AROUND THE DRILL BIT TO ACT AS A DEPTH GAGE.

- 11. Carefully drill a 3/32 diameter hole for each leg of the horn. Drill 1/16" deeper than the length of the control horn leg. These holes should be centered in the 3/16 thickness of the elevator, and square with the front (hinge line) edge of the elevator.

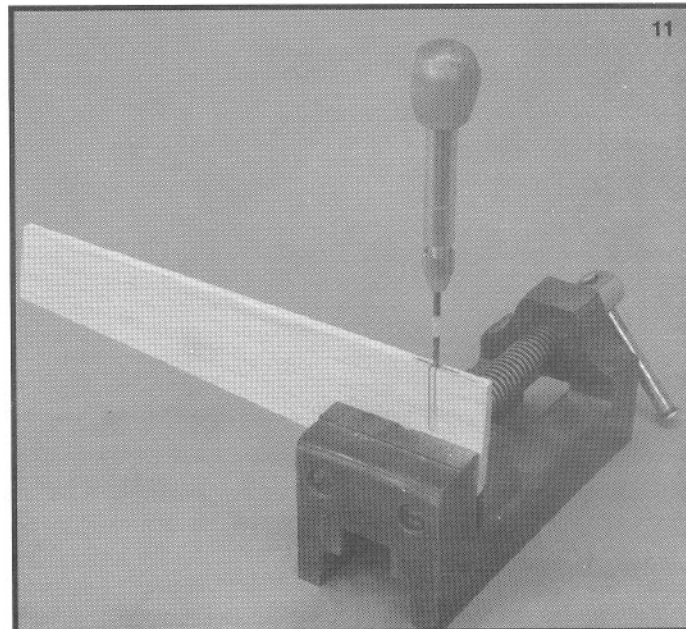

□ 12. On the hinge line surface, cut a groove from the 3/32 drilled hole to the inner (root end) edge of the elevator. This is to get the wire recessed into the front surface of the elevator.

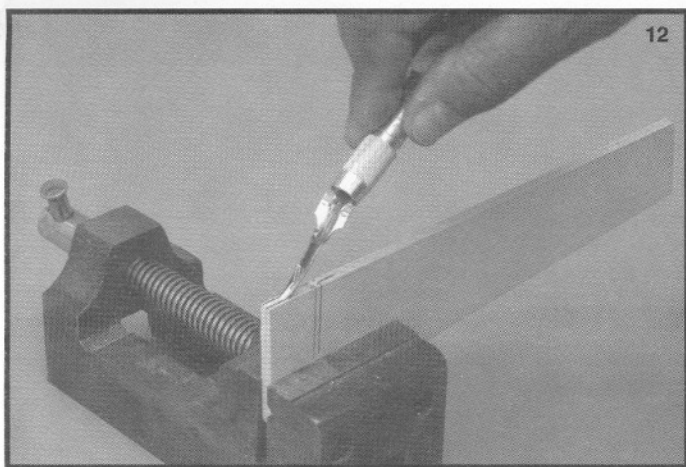

□ 13. Carefully round the leading edges of both elevators, and, using a razor plane and a sanding block, taper the rear of both elevators to 1/16". Round the tips with a sanding block. Sand everything with 220 grit sandpaper when through. See Section GG of the plan for an end view of the elevator.

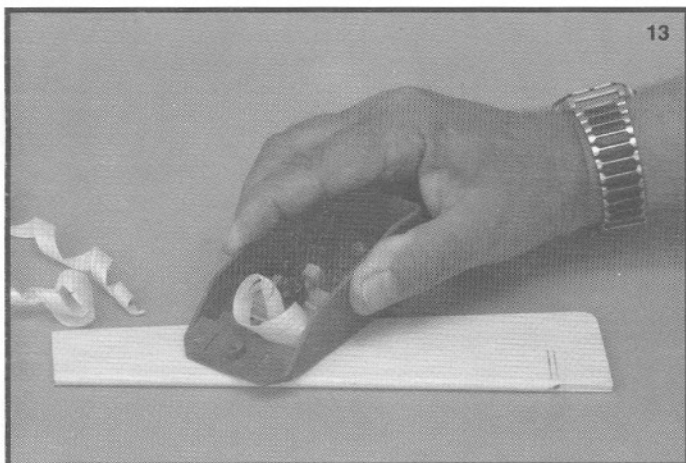

□ 14. Be sure to check the 4" center mount control horn for straightness and be sure the two legs are parallel before doing the next step. Carefully bend the horn to get it as straight as possible.

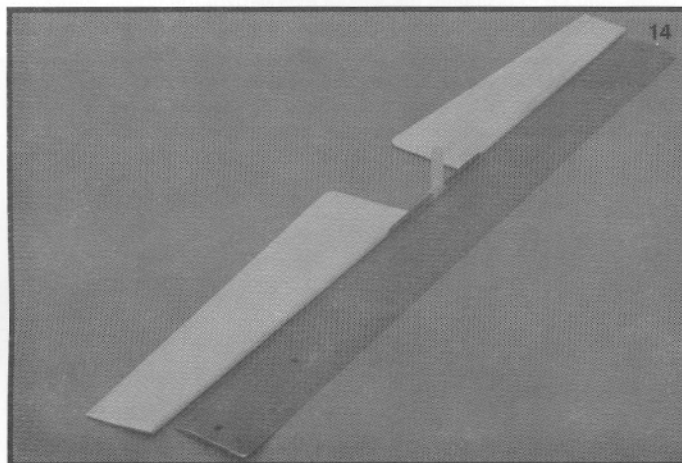

□ 15. Glue the 4" control horn into the front of both elevators, using Sig 5 minute epoxy, or thick CA. Use a straight edge to double check straightness. The hinge will bind if the two elevators are not in a straight line. Finish sand with 220 grit paper. This completes the canard and elevators for now.

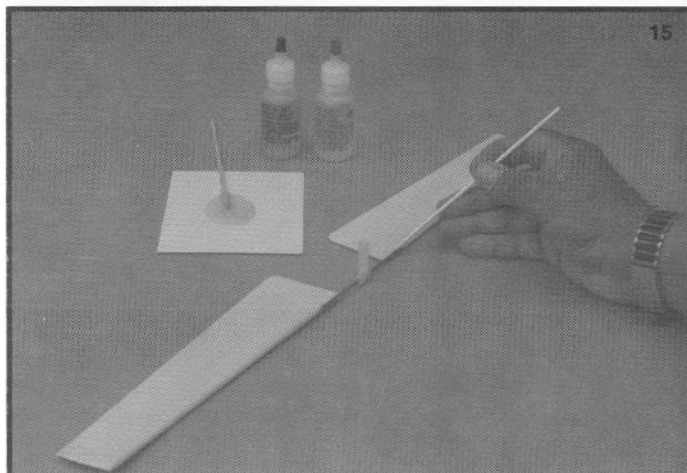

WING CONSTRUCTION.

□ 16. Untape the foam shipping block and remove the wing cores and save the foam shipping cradles as they will be useful later.

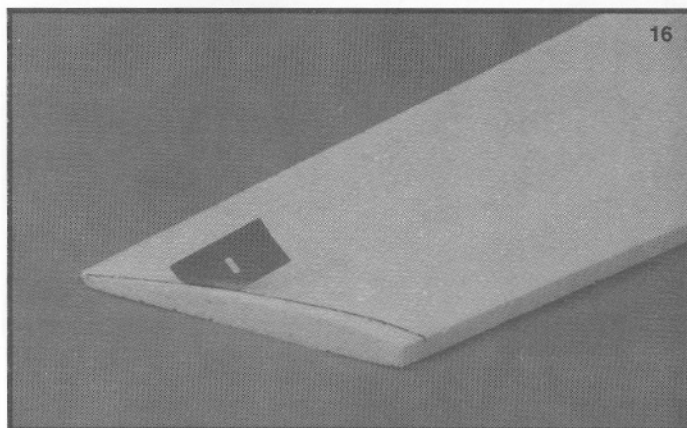

IMPORTANT: Find the template provided in the center portion of this manual to trim the wing core outer tips to the correct 4° "toe in". The "toe in" of the wing fins is important. It keeps the airplane from skidding since no rudder control is provided. Use the "TIC" marks provided to mark your cores and then carefully cut the outer ends of the cores to the required 4° "Toe-In". Use a new Razor Blade.

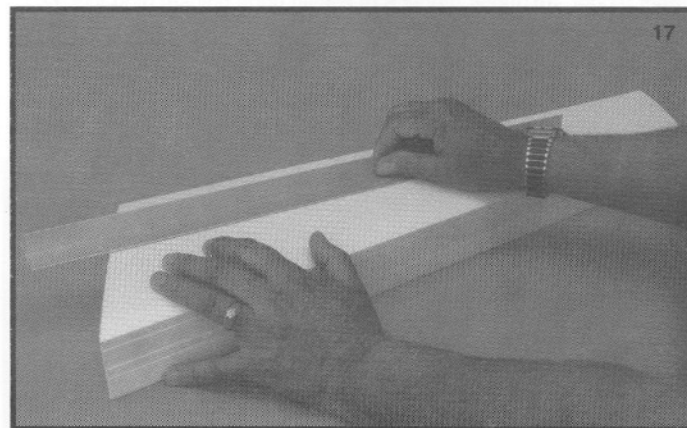

□ 17. Lightly sand any irregularities or cutting wire marks from the foam wing cores with #220 grit sandpaper used on a long sanding block. Sand the ends of the cores smooth, being careful not to change their angles.

□ 18. With a soft pencil, draw a line parallel to the leading edge of the wing cores, 2" back from the front edge on the top and bottom surfaces of the cores.

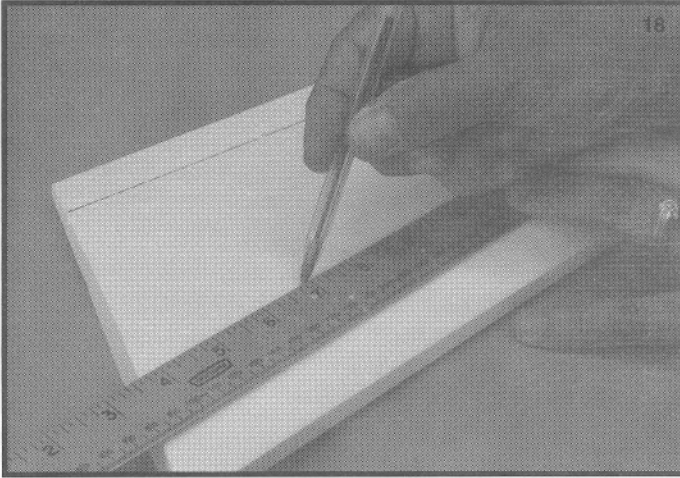

□ 19. With a soft pencil, draw a line parallel to the trailing edge of the wing cores, 1" forward from the edge, on the top and bottom surfaces of each core.

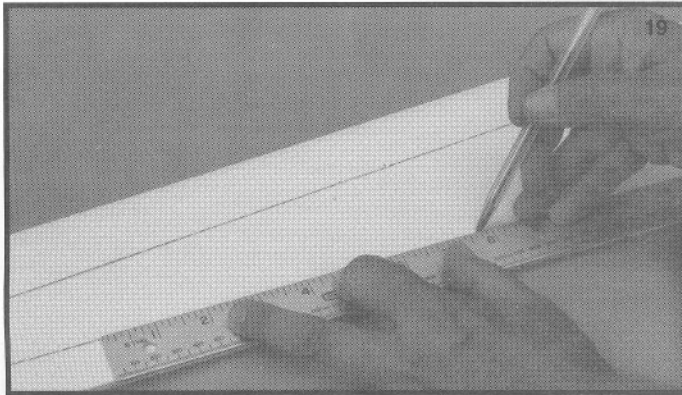

□ 20. Find four of the 1/32" x 3" x 30" balsa sheets. Using a straight edge, carefully true up the edges of these sheets. The idea is to get straight, parallel edges with as little material removal as is possible.

□ 21. Cut a 2" wide strip from one edge of each of these four sheets. These will be the leading edge sheets. The part that is left will probably be 7/8" to 1" wide, depending on how much material you had to remove to get the sheets straight. These four pieces will be the trailing edge sheets.

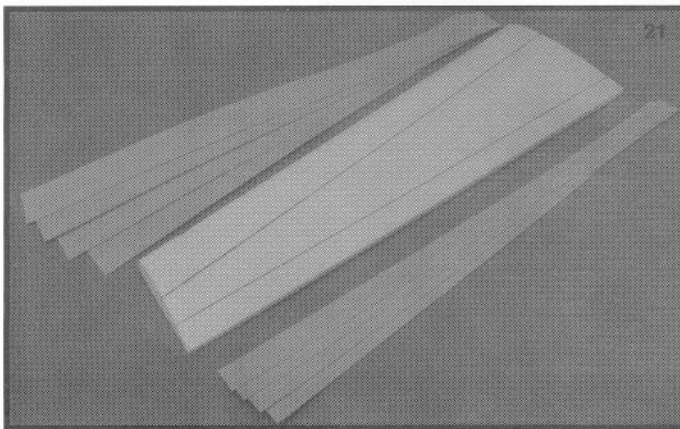

□ 22. Cut all of the leading edge, and trailing edge sheeting pieces to a length that is approximately 1/4" longer than the cores. Don't forget to cut the taper on the ends.

□ 23. Using 3M 77™ spray adhesive, or Sig Kwik Bond, lightly coat the area of the cores between the pencil lines and the leading and trailing edges of the cores.

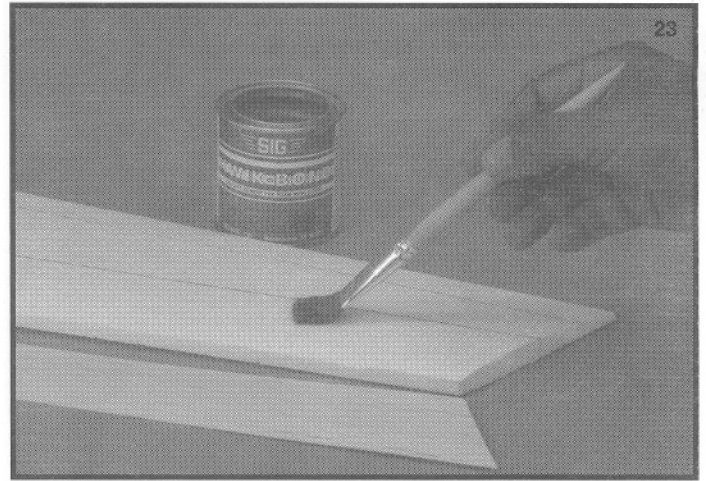

□ 24. Using 3M 77™ spray adhesive, or Sig Kwik Bond, lightly coat the proper surfaces of the 1/32" x 2", and 1/32" x 1" sheeting. Allow the adhesive on the cores and sheeting to dry for at least 25 minutes.

□ 25. One piece at a time, carefully locate the 1/32" sheets over their respective positions on the cores and gently rub them into place. The front of the L.E. sheeting should be flush with the L.E. of the cores, and the rear of the T.E. sheeting should be flush with the T.E. of the cores.

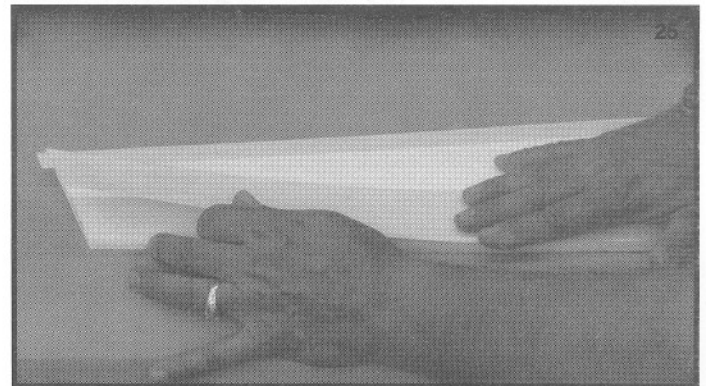

□ 26. After all eight (8) pieces of 1/32" balsa sheeting have been positioned, and rubbed down onto the cores, put the two wing cores back into their shipping cradles. On a flat, sturdy work surface, apply a weight (notice that we have shown one gallon jugs filled with water). Set the jugs on a piece of wood that is slightly larger than the wing cores, and try to distribute the weight evenly over the cores. Allow the cores to remain weighted for a couple of hours.

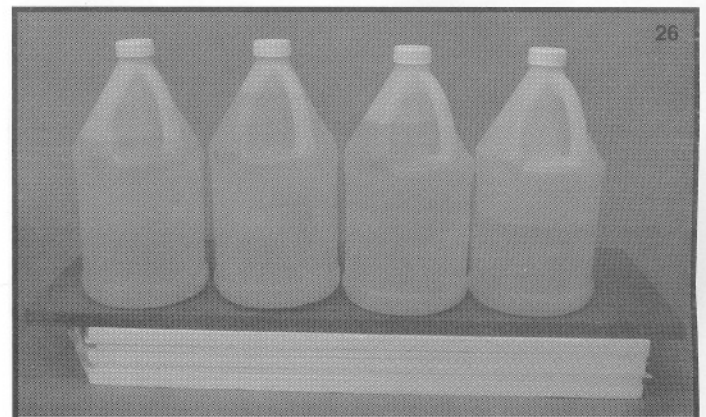

□ 27. Remove the cores from the shipping cradles and, using a sharp razor blade, trim the excess length of sheeting from the cores, and sand the end and edge surfaces of the cores smooth and straight.

□ 28. Find the last piece of $1/32"$ x $3"$ x $30"$ balsa. Carefully cut off eight, $2"$ long pieces. Sheet the wing center section, using the same materials and methods you used to apply the L.E. and T.E. sheeting. The balsa to balsa part of the joints should be made with Sig Bond, or Sig Weld glue. The center section is sheeted on both the top and bottom surfaces.

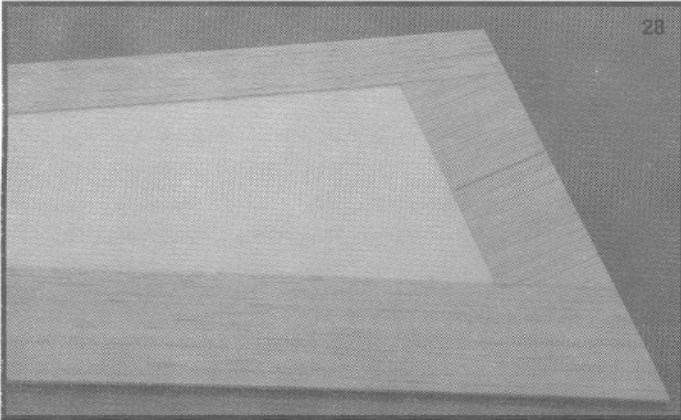

□ 29A. Find the $1/32"$ x $1/4"$ x $30"$ cap strip material. Apply the cap strips to the cores, between the leading and trailing edge sheeting, spacing them as shown on the plan. Use the template provided in the manual center section to draw reference lines for applying the cap strips.

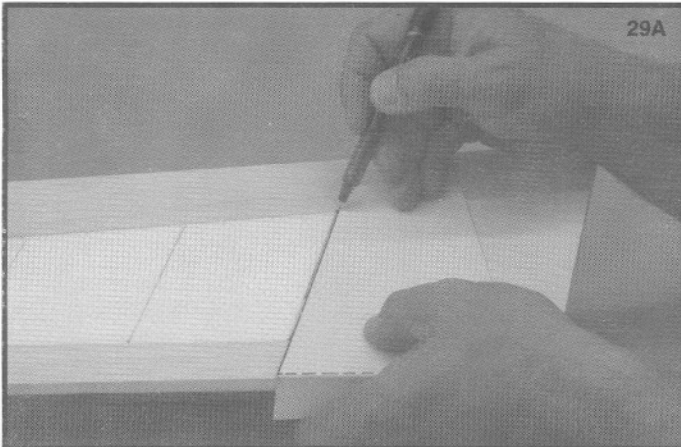

□ 29B. It is suggested that you use either foam friendly C/A glue, or Sig Bond, to install the cap strips. Small patches of masking tape will help keep the cap strips in position while the glue dries. Using sheeting material left over from the center section, make the cap strips at the very tip of the wing, next to the tip fin, $1/2"$ wide. This provides extra strength where the tip fins attach.

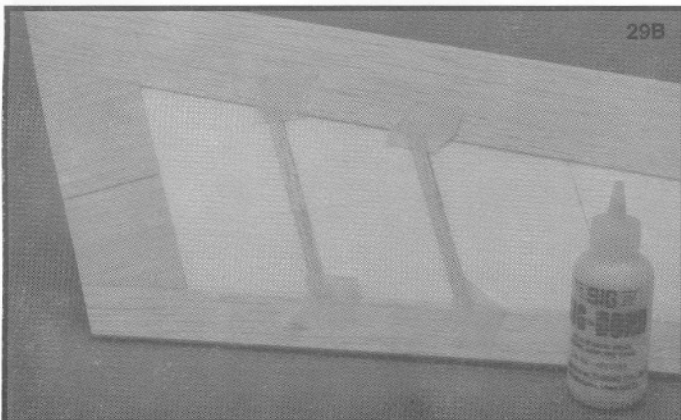

□ 30. Find the two, $1/8"$ x $1/4"$ x $30"$ balsa trailing edge pieces. Cut them to a length about $1/4"$ longer than the core trailing edge length. Using Sig Bond, or Sig Weld, and masking tape, attach them to the trailing edge of the wing cores. Only a thin film of adhesive is necessary. Once they are dry, remove the tape and trim away any excess balsa.

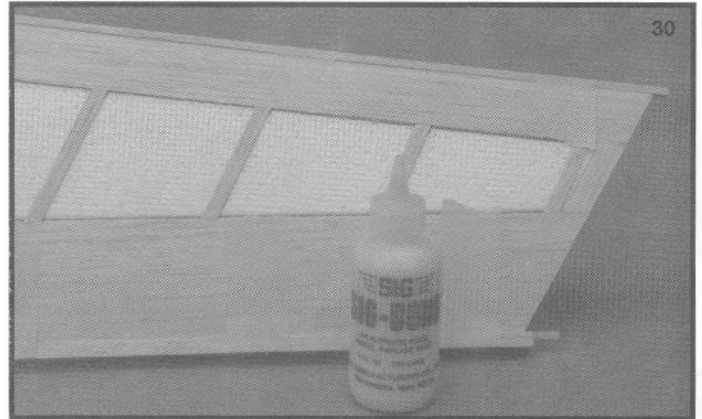

□ 31. Find the two, $1/4"$ x $1/2"$ x $30"$ balsa leading edge pieces. One of them has a $1/8"$ groove cut the length of one of the $1/2"$ wide faces. This will be the **LEFT HAND** leading edge piece. The groove is for the $1/8"$ O.D. x $32"$ plastic antenna tube.

□ 32. Sand the O.D. of the $1/8"$ O.D. x $32"$ plastic antenna tube with 180 grit paper. Glue it into the groove in the $1/4$ x $1/2$ x 30 , Left Hand leading edge piece, using Medium CA, or Epoxy. A small dab of adhesive every $2"$ is adequate. Use small patches of Masking tape to keep it in place until the glue dries.

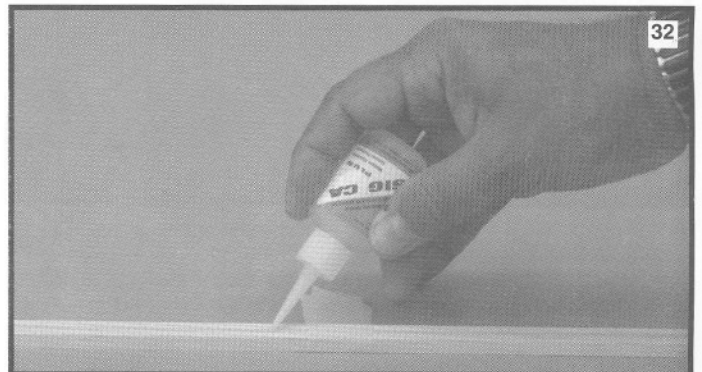

□ 33. Cut both leading edge pieces to a length about $1/4"$ longer than the Leading edge of the cores. Using Sig Bond and masking tape, attach them to the leading edge of the wing cores. Once they are dry, remove the tape and trim away any excess balsa. Leave $1/2$ inch of the plastic tube protruding from the left hand leading edge, on the **TIP** end only.

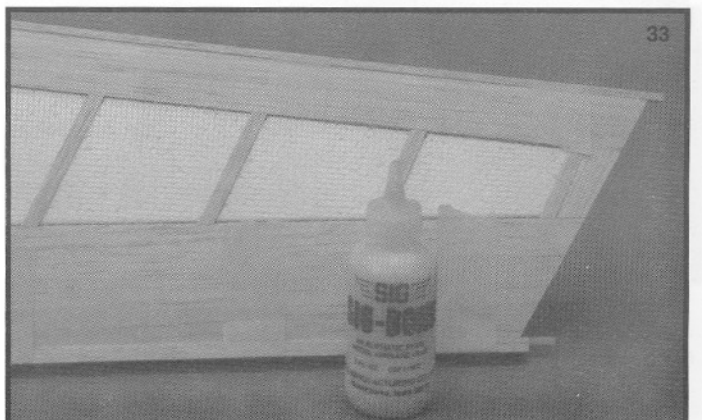

□ 34. Carefully sand the root end of each core, so that with one wing panel laying flat on the table, (top side up please) and with the tip of the other (top side up also) panel raised 1/2" above the table, there is a tight fit at the wing center joint line. Tri- Star will fly O.K. without any dihedral, but the wings appear to "droop". The small amount of dihedral added in this step, eliminates the "droop" look.

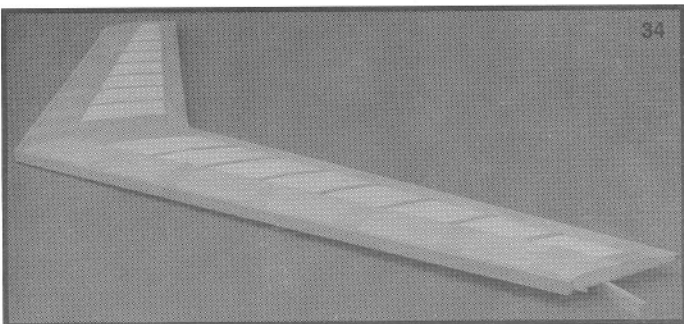

□ 35. Using 5 minute epoxy, and masking tape, join the two wing panels at the center line.

DO NOT FILL THE ANTENNA TUBE WITH EPOXY.

Don't forget your 1/2" dihedral block. Be sure the L.E. and T.E. surfaces match up. Wipe away any excess epoxy before it hardens.

□ 36A. Using a Razor Plane and long sanding block, carefully shape the leading edges on both wings.

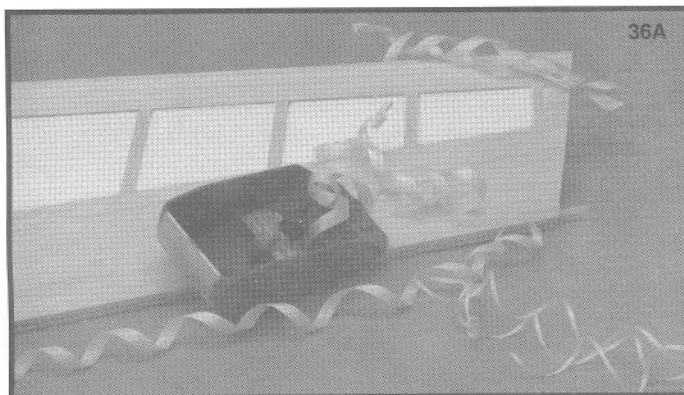

□ 36B. Cut out the sanding guide patterns on the plan, and use them for reference when shaping the Leading edges. The finished shape should transition smoothly from the root to the tip.

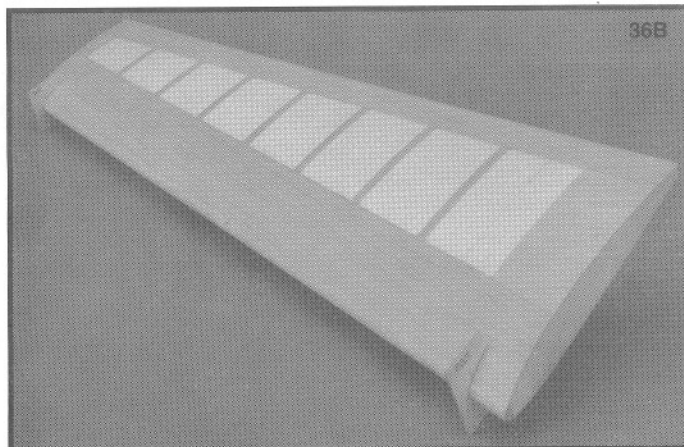

□ 36C. Remove the triangular piece at the front, center of the wing as shown at the top of the plan. This is best done with a Razor Saw or a bandsaw. This opens the access to the antenna tube.

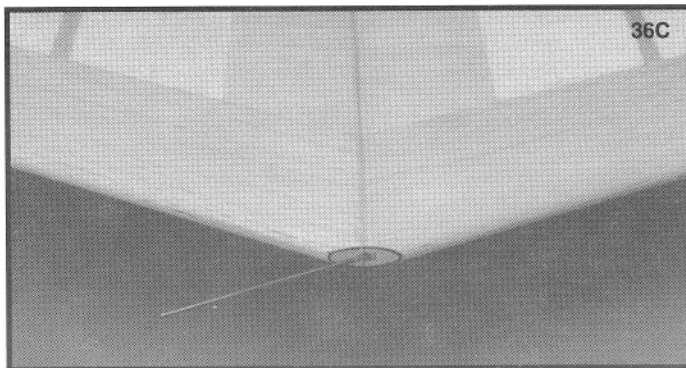

□ 37. Carefully sand the entire wing, using a long sanding block and #220 sandpaper. Remember, the wing sheeting is only 1/32" thick, so work slowly and try not to sand through it.

□ 38. Sharpen the end of a piece of 1/2" O.D. brass tubing. Do this by slightly tapering the outside with a file, and scraping the inside with an Exacto #11 blade. This is the tool that will be used to bore the holes for the wing bolt dowels. It is important that it be extremely sharp to cut through the epoxy used at the wing center joint.

□ 39. Carefully measure from the plan, the location of the two wing bolt dowels. Mark these two locations. With the wing core assembly resting in the shipping cradles, on a flat work surface (bottom side down) and using the brass tube boring tool, made in step #38, carefully bore a 1/2" diameter hole through the core and sheeting, staying centered on the wing centerline. Keep the boring tool square with the work table surface. Work slowly and rotate the tube so you don't crush the core. Re-sharpen the tool as necessary to keep it cutting cleanly.

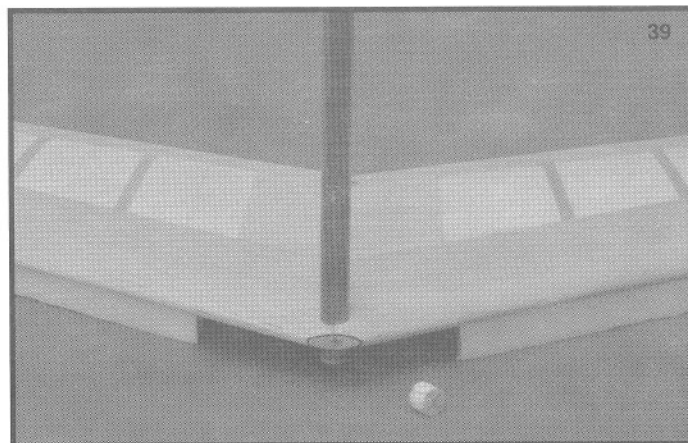

□ 40. Once the holes are bored, the wing assembly is completed until the fuselage is assembled. **DO NOT INSTALL THE TWO WING BOLT DOWELS AT THIS TIME...**Go on to the Fuselage assembly.

BUILDING THE FUSELAGE.

□ 41. Using the Parts Identification Drawing as a guide, locate and identify all the laser cut balsa and ply fuselage parts if you haven't already done so. Carefully write the name, or identity letters of each part, on that part, with a soft pencil.

□ 42. Cover the fuselage side view on the plan with waxed paper. Pin down one of the 3/32" balsa fuselage sides. Attach one of the 1/32" ply front fuselage doublers to the fuselage side using Sig Slow C/A. (a dot of C/A every 1/4" in all directions is sufficient)
Line up the canard slots at the front and maintain a 3/32" distance between the bottom edge of the ply and the bottom edge of the balsa.

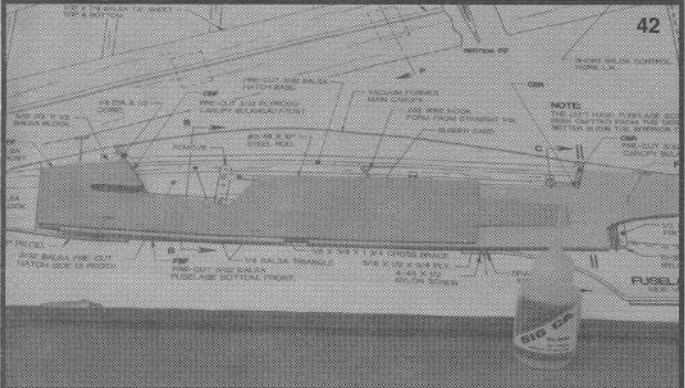

□ 43. Install the rear 1/32" ply doubler to the fuselage side, using Sig Slow C/A. Alignment is obtained by using the tab at the front of the ply part and maintaining a 3/32" distance between the edge of the ply and the balsa at the rear of the fuselage. The alignment tab at the front may require some slight adjusting with a sanding block to achieve a perfect fit. The slots at the extreme rear of the fuselage will be helpful in setting the 3/32" distance.

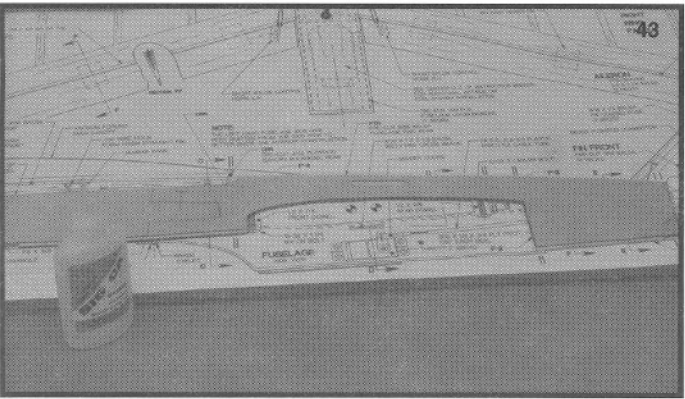

□ 44. Using the "TIC" marks provided, draw the locations of the F- 1, F- 2, F- 3, and F- 4 bulkheads on the ply doubler, using a soft pencil.

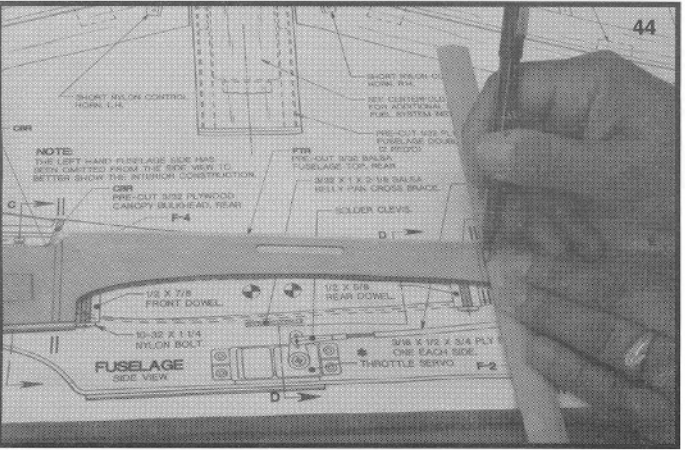

□ 45A. Using the ply part as a guide, use a sharpened piece of 3/16" O.D. brass tube to open the ends of the aileron pushrod clearance slots.

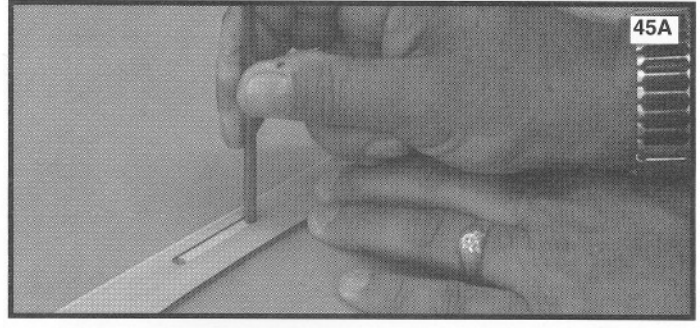

□ 45B. Remove the material left between these two holes with a sharp #11 exacto blade.

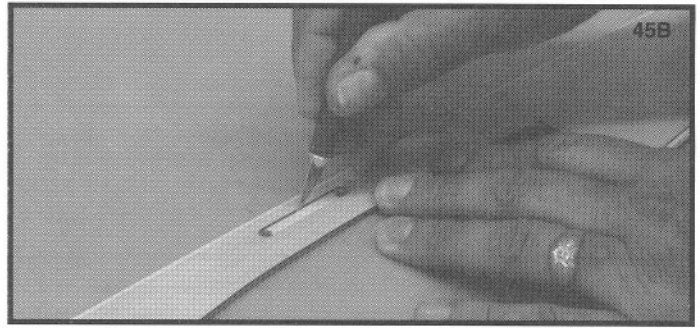

□ 46. Find the three sticks of 1/4" balsa triangle material provided. Install a piece of triangle stock along the bottom edge of the fuselage, that extends from the front of the fuselage to the front locator line for bulkhead F- 4. The bottom of the Triangle stock should be flush with the bottom edge of the 1/32" ply doubler. Leave a 3/32" gap for the F- 4 bulkhead and then add a 5/16" long piece of triangle stock from the rear locator line for F- 4 to the front edge of the wing opening.

□ 47. At the bottom rear of the fuselage, install a 4 1/2" long piece of 1/4" triangle stock. The bottom edge of the triangle should be flush with the bottom of the 1/32" ply doubler.

□ 48. At the top, front, of the fuselage, cut, and install a 2" long piece of 1/4" triangle stock. This will trim flush with the 1/32" ply doubler, front and rear.

□ 49. At the top rear of the fuselage, cut and install a 13 1/4" long piece of 1/4" triangle stock. The front end of this piece is trimmed flush with the rear edge of the hatch opening. The rear edge of this piece is trimmed flush with the rear of the fuselage. The top is even with the 1/32" top edge of the rear ply doubler.

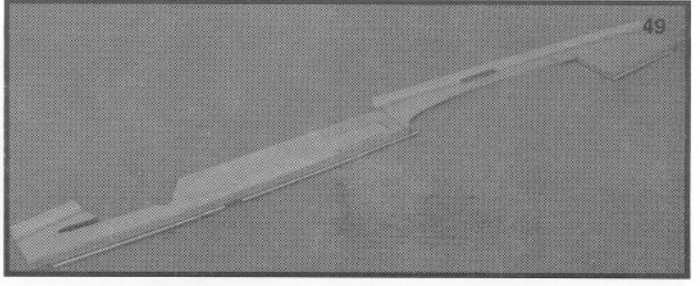

□ 50. Using your sharpened 3/16" dia. brass tube, and exacto knife, trim away the small sliver of triangle stock that covers the aileron

pushrod slot.

□ 51. Repeat steps 42 through 50, but create a mirror image of the first part. This assures that you have both Right hand and Left Hand fuselage sides.

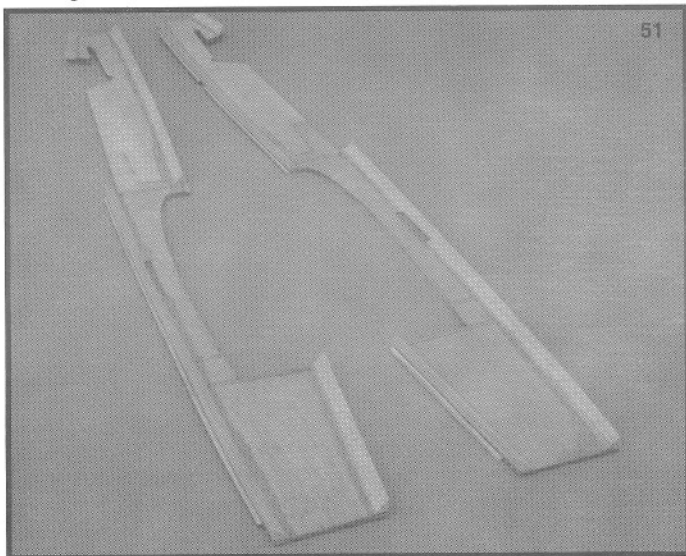

BUILDERS TIP: SINCE 1/4" X 1/4" TRIANGLE STOCK IS ALMOST IMPOSSIBLE TO CUT TO EXACT SIZE, SOME TRIMMING OF THE 45° CORNERS ON THE BULKHEADS INSTALLED IN THE NEXT FEW STEPS MAY BE NECESSARY. TRY TO ACHIEVE A GOOD FIT OF THE FLAT SIDE, TOP, AND BOTTOM SURFACES.

□ 52. Glue the two F- 1 (3/32" ply) pieces together, using epoxy or medium C/A. Make sure all the edges and holes line up properly.

□ 53. Locate and install the F- 4 (3/32" balsa) bulkhead between the two fuselage sides. The edge with the corners cut off at 45° goes at the top of the fuselage. The bottom surface of the F- 4 bulkhead should end up flush with the bottom of the 1/32" ply doubler, and the bottom of the 1/4" balsa triangle stock.

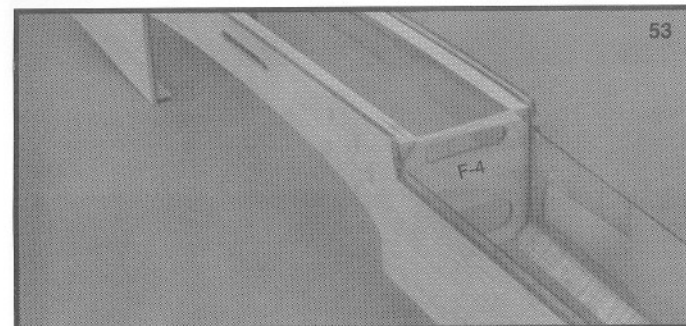

□ 54. Install the two F- 1 bulkheads previously glued together, between the two fuselage sides. Use Medium C/A or Epoxy. The rear face of the F- 1 bulkheads should be flush with the rear face of the fuselage.

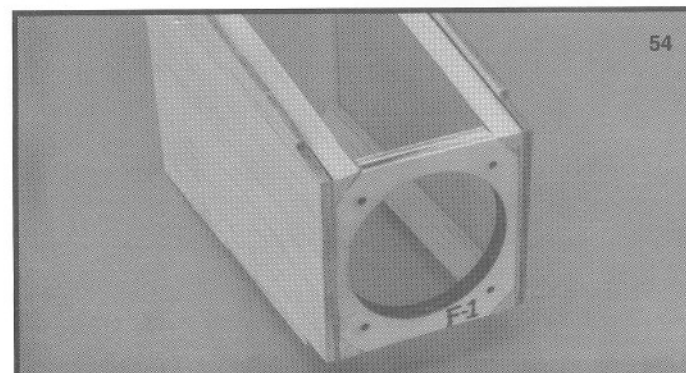

□ 55. Locate and install the F- 3 bulkhead. The 45° corners are installed at the top of the fuselage. The top surface of the F- 3 should be flush with the top of the 1/4" triangle stock.

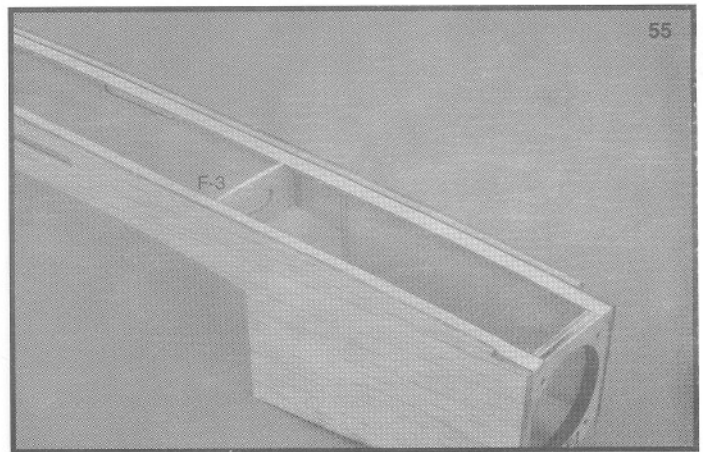

□ 56. Locate and install the F- 5 bulkhead. The 45° corners are installed at the top of the fuselage. (Remember, some trimming of the 45° corners may be necessary). Trim the bottom of the F- 5 bulkhead so it is even with the small slanted area at the top, rear, of the canard slot. This is necessary to allow the canard to slide into position later.

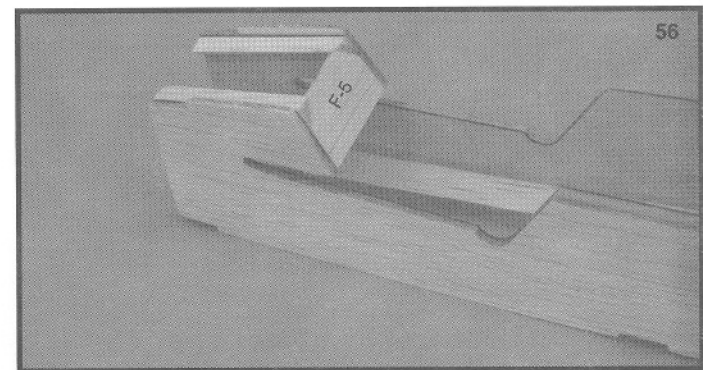

□ 57. Locate and install FBF (fuselage bottom, front), using the alignment tabs for alignment. Rubber bands or masking tape can be used to hold the parts together while you apply Sig Thin C/A.

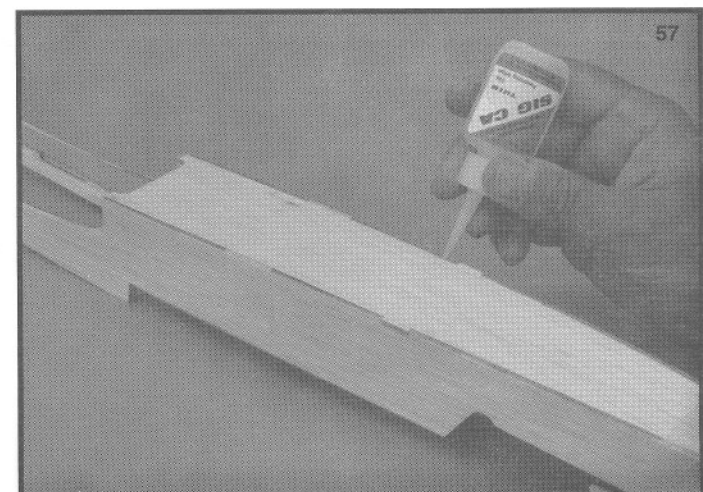

TYPICAL ENGINE - FUEL TANK INSTALLATION.

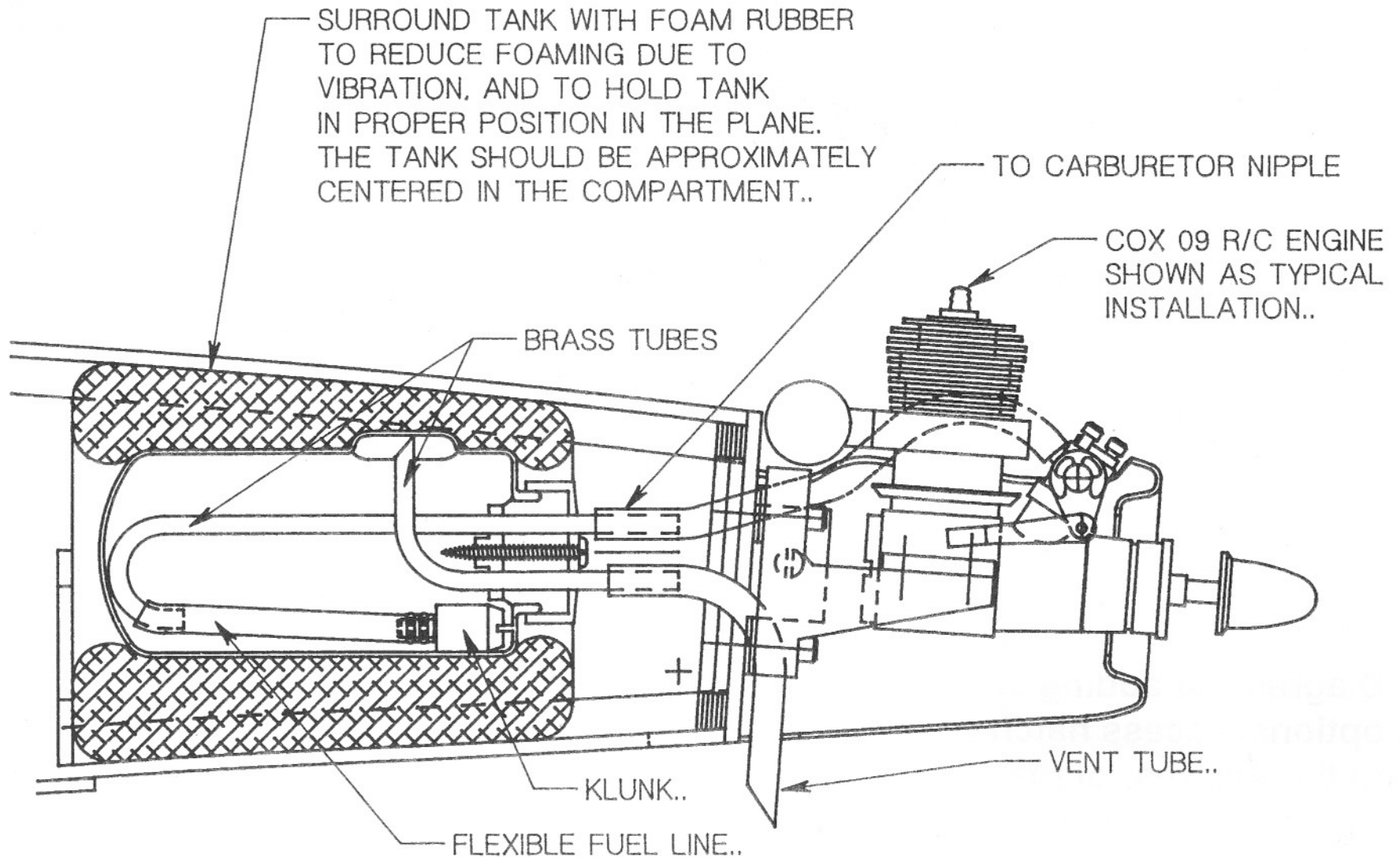
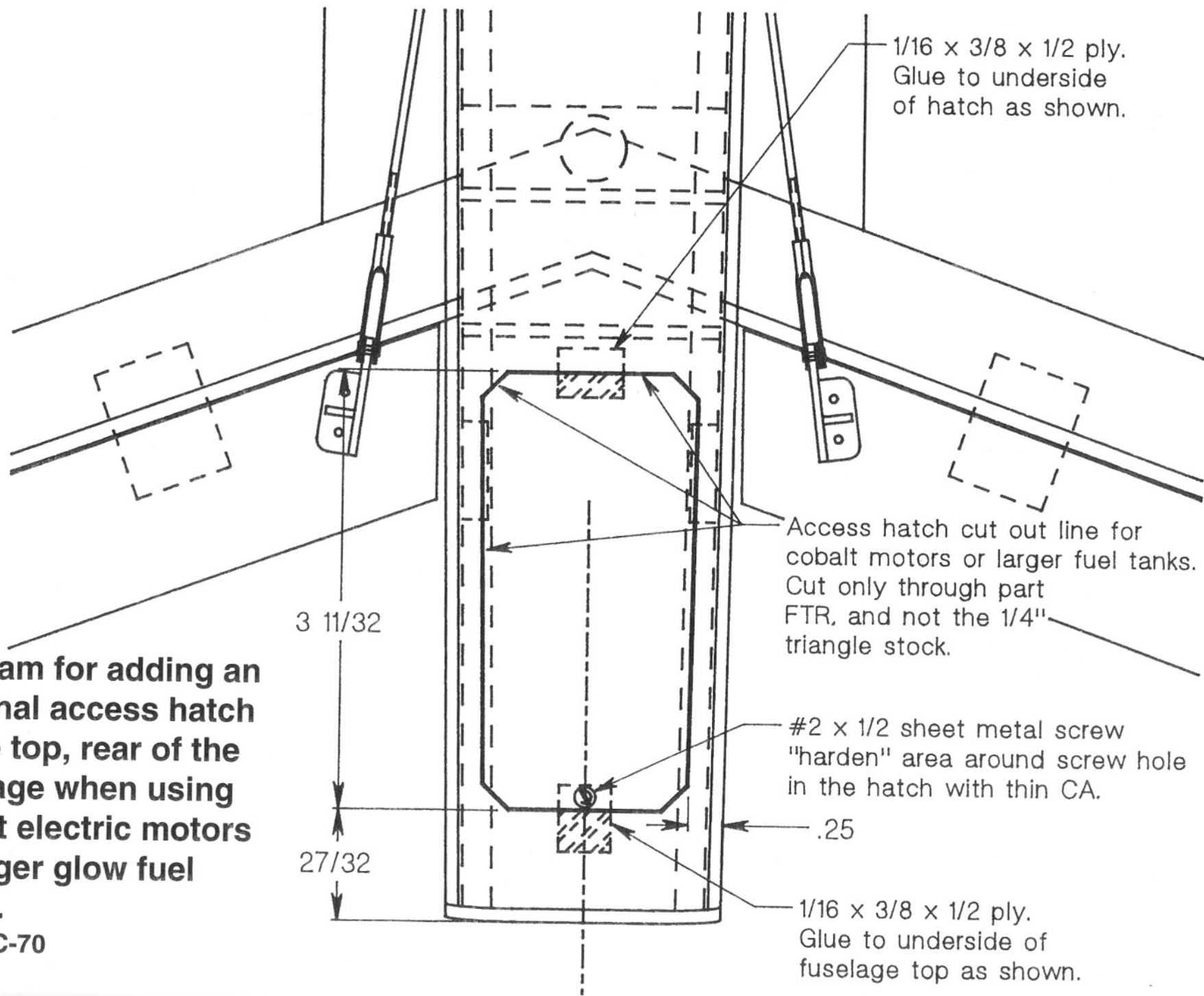
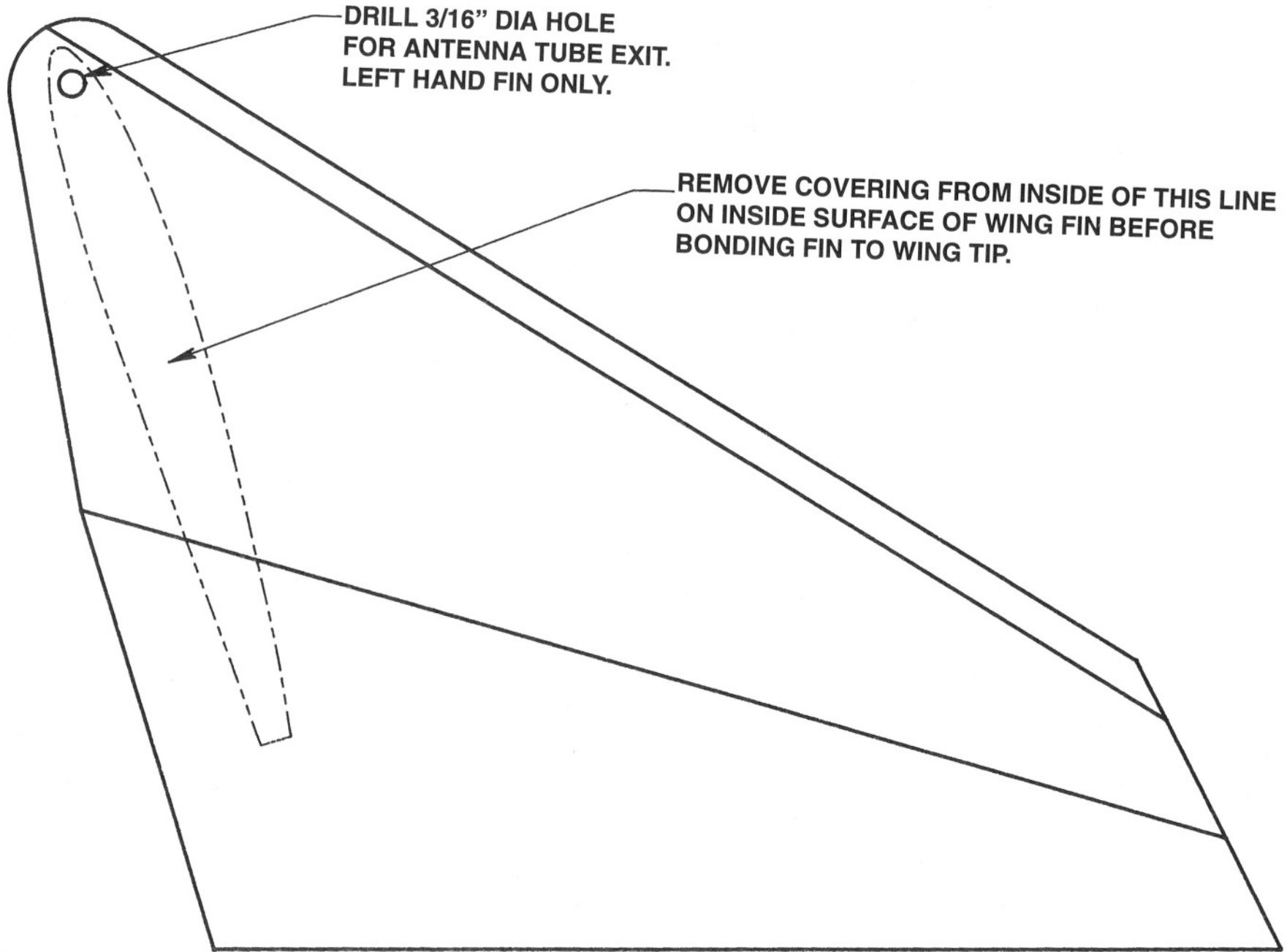

Diagram for adding an optional access hatch to the top, rear of the fuselage when using cobalt electric motors or larger glow fuel tanks.

KIT #RC-70





KIT #RC-70

**TOP SURFACE OF
RIGHT HAND WINGTIP**

FRONT

**CAREFULLY REMOVE
CROSSHATCHED AREA.**

**SHAPE OF FOAM
WING CORES AS RECEIVED.**

**CAREFULLY REMOVE
CROSSHATCHED AREA.**

**TOP SURFACE OF
LEFT HAND WINGTIP**

FRONT

KIT #RC-70

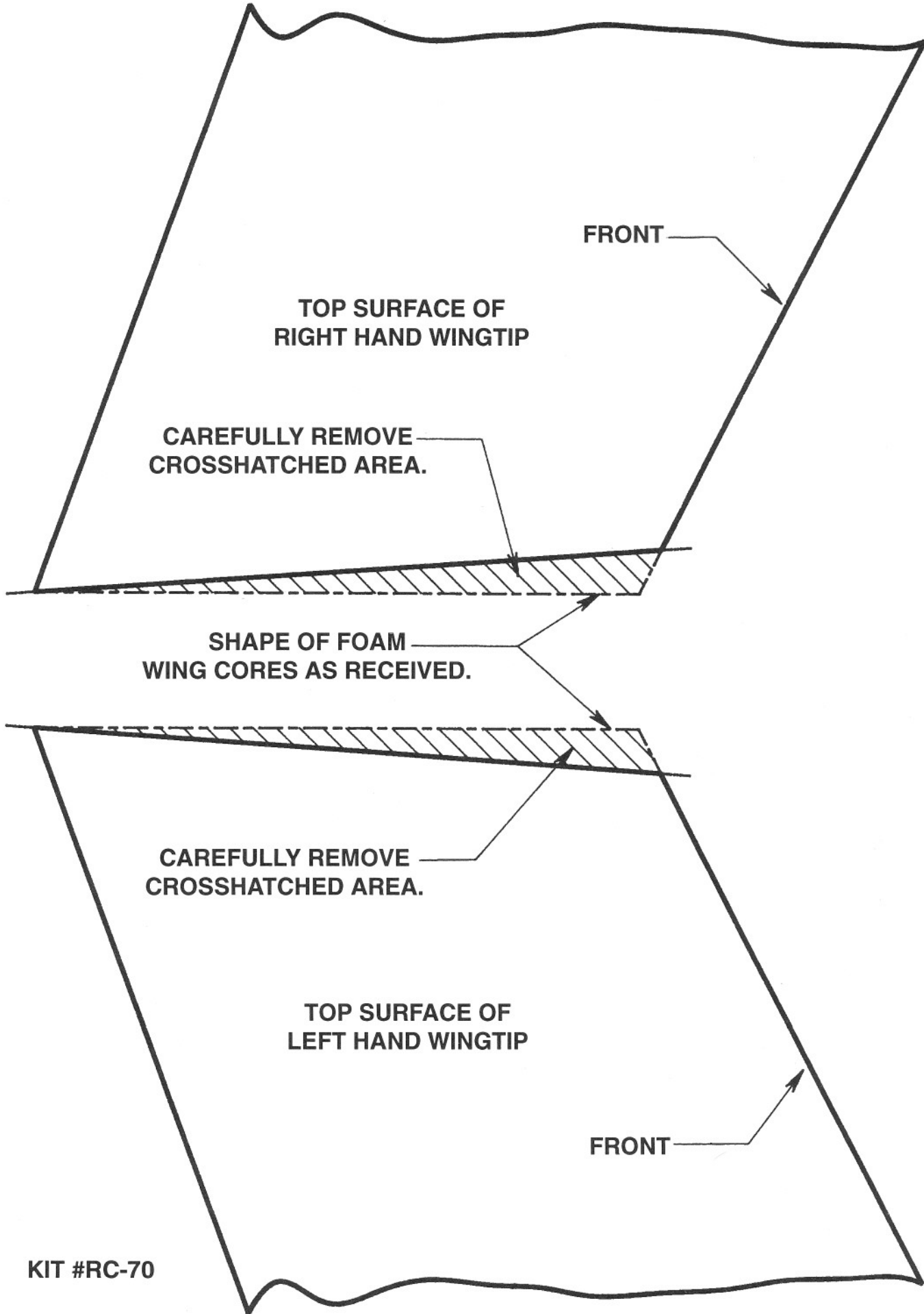

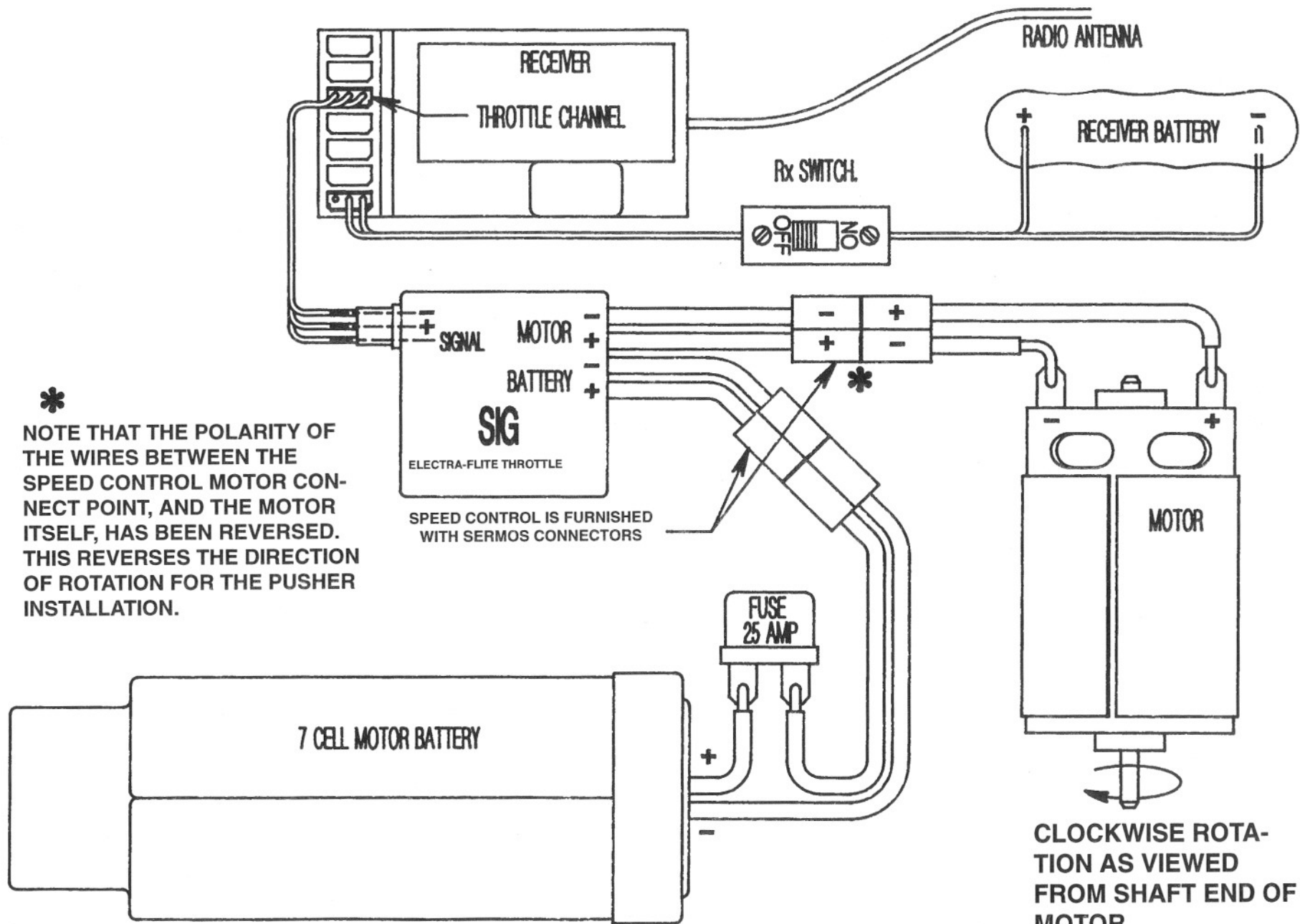

*
NOTE THAT THE POLARITY OF THE WIRES BETWEEN THE SPEED CONTROL MOTOR CONNECT POINT, AND THE MOTOR ITSELF, HAS BEEN REVERSED. THIS REVERSES THE DIRECTION OF ROTATION FOR THE PUSHER INSTALLATION.

SPEED CONTROL IS FURNISHED WITH SERMOS CONNECTORS

CLOCKWISE ROTATION AS VIEWED FROM SHAFT END OF MOTOR

ELECTRIC FLIGHT SYSTEM SCHEMATIC DRAWING



CAP STRIP ANGLE GUIDE

FOLD ALONG THIS LINE

KIT # RC-70

USE THIS SKETCH TO CREATE
YOUR OWN TRIM SCHEME.
XEROX ADDITIONAL COPIES
BEFORE YOU BEGIN...

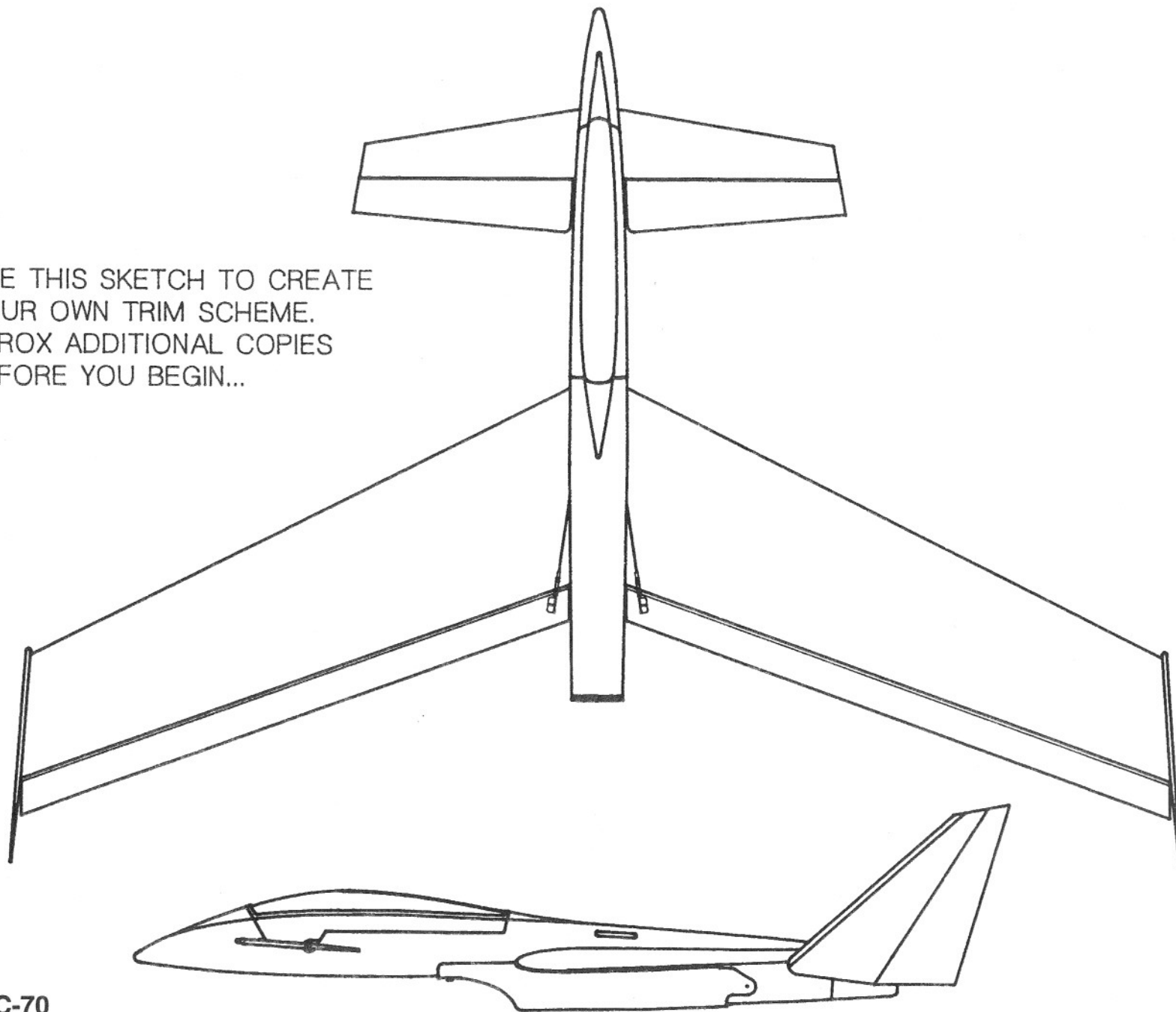

KIT #RC-70

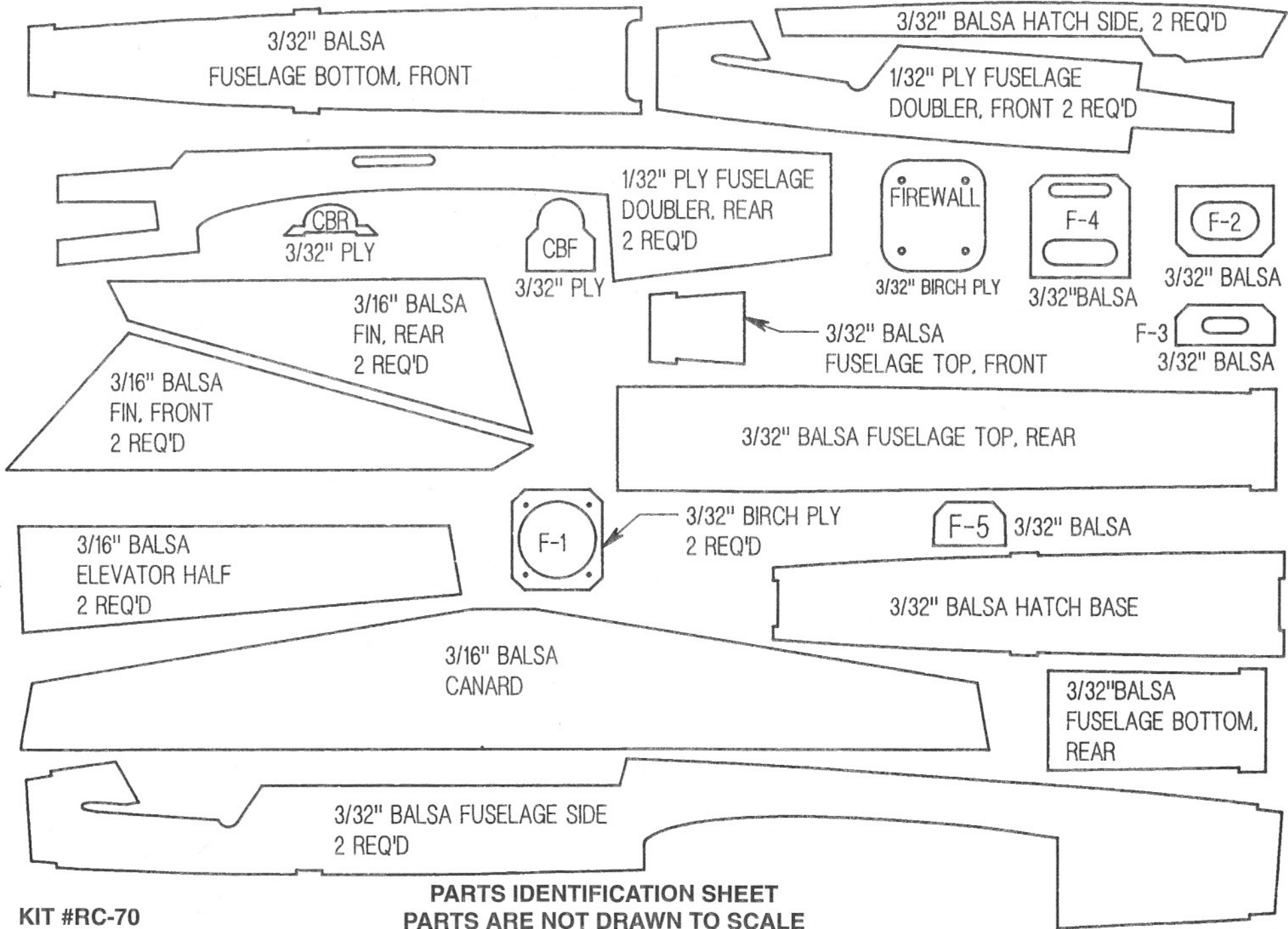

KIT #RC-70

PARTS IDENTIFICATION SHEET
PARTS ARE NOT DRAWN TO SCALE

□ 58. Locate and install FTF (fuselage top, front), using masking tape or rubber bands to hold the parts in place while you apply Sig Thin C/A.

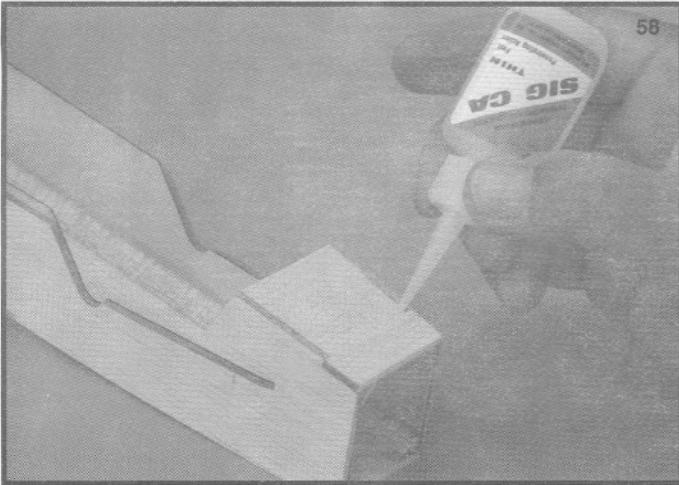

□ 59. Find and install F- 2. Put a generous bead of C/A around the rear face of F- 2 where it touches the fuselage sides.

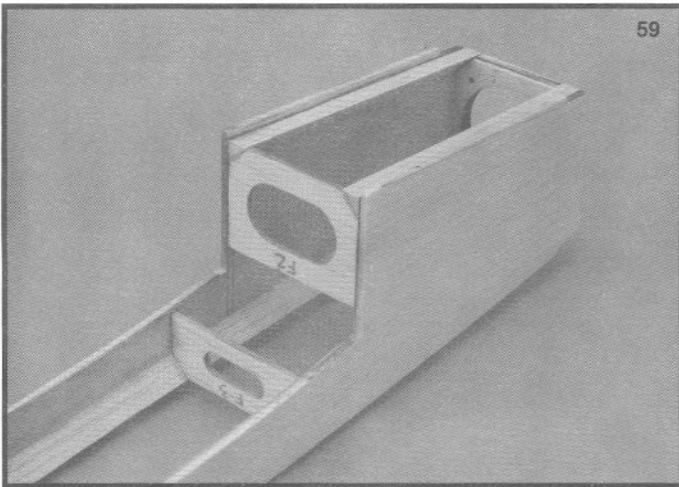

□ 60. Locate and install FBR (fuselage bottom, rear). Once again, tape or rubber bands will hold the parts in position as you apply Sig Thin C/A. Glue FBR to F- 1, F- 2, and the ply fuselage side doublers.

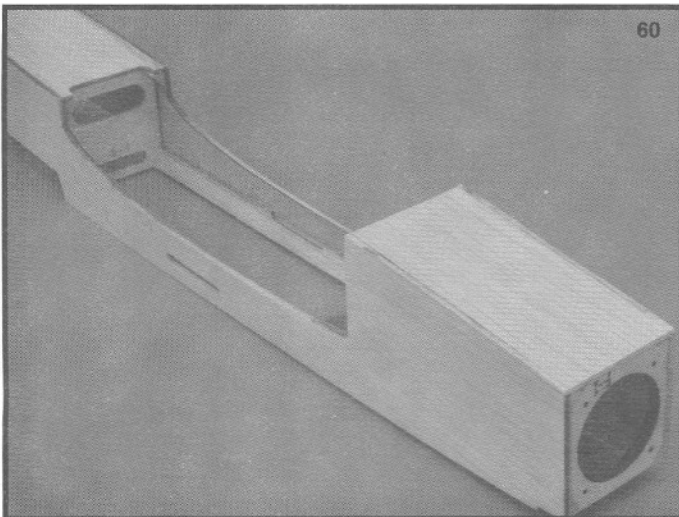

□ 61. Find and install the 3/16" x 3/4" x 2" ply front wing bolt plate against the rear of the F- 4 bulkhead, and between the two 1/32" rear fuselage doublers.

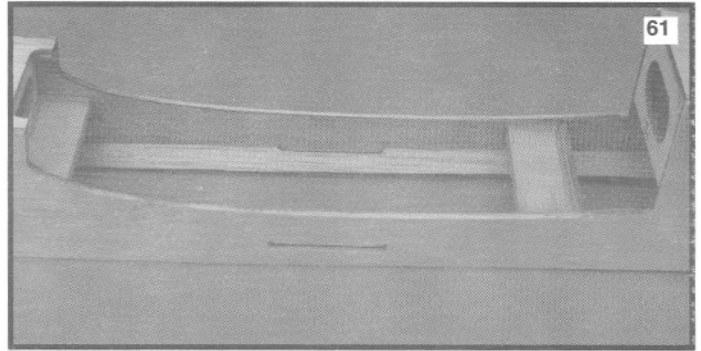

You may have to sand the corners of this piece to clear the glue fillet on the rear of the F- 4 bulkhead. The bottom surface of the 3/16" ply bolt plate should be exactly 1" above the bottom surface of the FBF fuselage bottom, as shown in the sketch below. Apply a generous bead of Sig Slow C/A all around this part after initial attachment with Thin or Medium C/A.

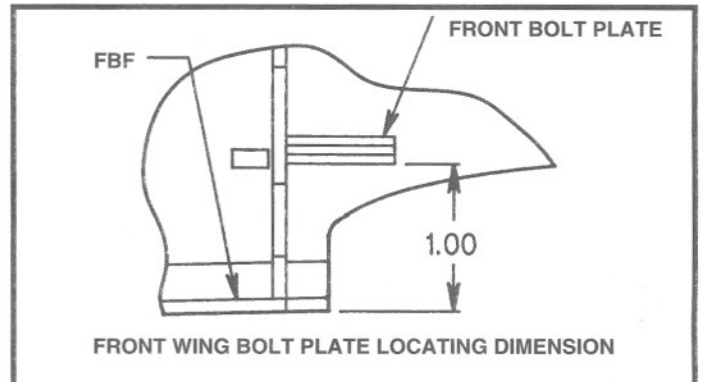

□ 62. Find and install the 3/16" x 3/4" x 2" ply rear wing bolt plate, against the front of the F- 3 bulkhead and between the two 1/32" ply fuselage doublers. Once again, you may have to sand the corners slightly to clear the glue fillet on the F- 3 bulkhead.

The bottom surface of the rear wing bolt plate must be .06" above the wing saddle at the front edge of the plate, and .125" above the bottom of the F- 3 bulkhead at the rear edge of the plate, as shown in the sketch below. Apply a generous bead of Sig Slow C/A all around this part after attaching it with thin, or medium C/A.

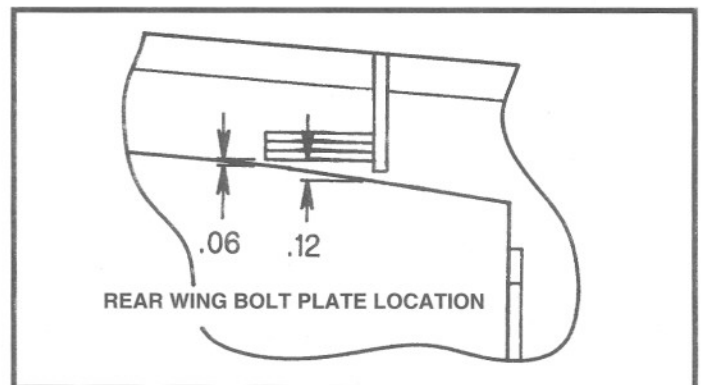

□ 63. "Harden" the inside edges of the aileron pushrod openings by soaking them with Thin C/A.

- ❑ 64. Find and install FTR (fuselage top, rear) using tape or rubber bands to hold the parts while you apply the C/A.

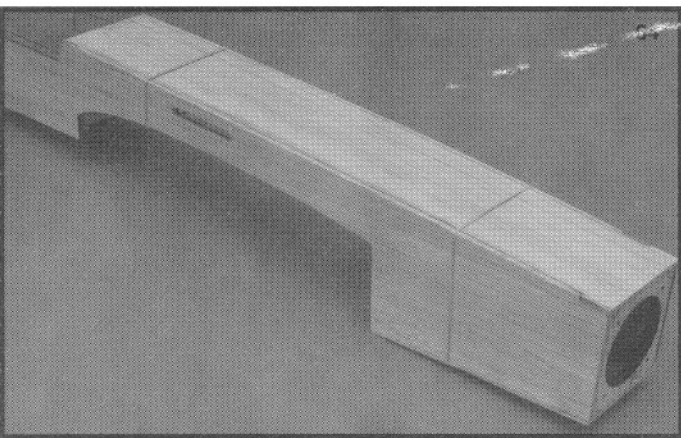

- ❑ 65. **NOTE:** If you are planning on building an Astro cobalt powered version of the electric Tri- Star, or are planning to use a fuel tank on your glow powered version larger than the 2 ounce tank shown, you will need to build an additional hatch on the top of the fuselage for installation and access to these components. This is because the large brush holders on the Astro cobalt motors will not fit through the hole in the F- 1 bulkheads, where the smaller "can type" motors will. In the center section of this manual is a diagram explaining the changes you will need to make. Make those changes before proceeding any further.

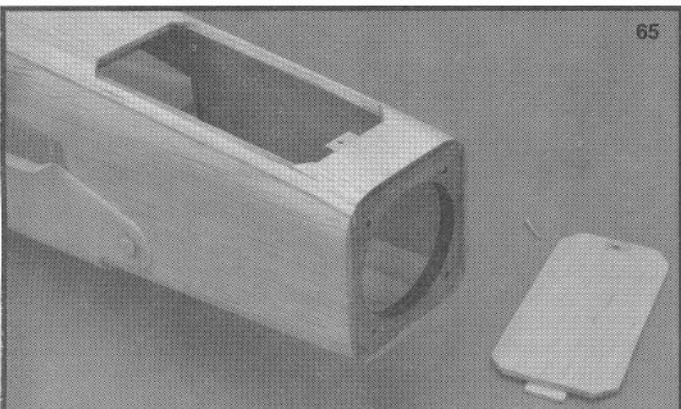

- ❑ 66. Lightly block sand the whole structure at this point.
- ❑ 67. Cut two pieces of 1/4" balsa triangle stock, 10 1/4" long. Install one of these along the top (curved side) of one of the hatch sides, leaving a 3/32" gap between the top of the triangle and the top of the hatch side. Trim the ends to match the hatch side piece.
- ❑ 68. Repeat step #67, creating a mirror image of the first hatch side. This assures that you have both Right, and Left, hand sides.

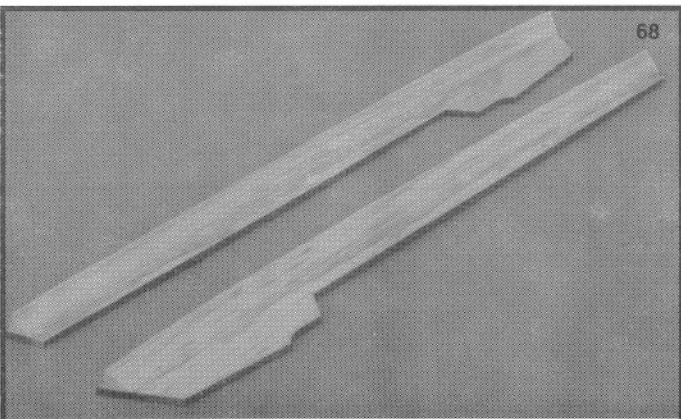

STEERABLE NOSE GEAR INSTALLATION.

NOTE: IF YOU ARE BUILDING THE SLOPE SOARING VERSION OF TRI- STAR, SKIP TO STEP #75.

- ❑ 69. Find the partially shaped balsa nose block. There is a Top, and Bottom to the nose block, so refer to the side view of the fuselage drawing on the main plan sheet to be sure you know which is which. On the rear surface of the nose block, drill a 5/16" diameter hole, 1/4" deep, as shown on Plan sheet #2.
- ❑ 70. Find the 3/32" x 1- 1/16" x 1- 9/16" ply nose gear mount. Using the full-size pattern from plan sheet #2, cut off the four corners, notch the center, and drill the four holes. When through, attach it to the back of the nose block as shown. Use Sig slow C/A, or epoxy.
- ❑ 71. Attach the nose gear wire, straps, collar, and washers to the nose gear mount, using the four #2 x 3/8" sheet metal screws provided.
- ❑ 72. Screw the #4- 40 Socket Head screw through the Nylon aileron connector as far as it will go, then unscrew it one- half turn. Next, screw them both into the wheel collar. With the nose gear axle pointed 90° to the fuselage centerline, the hole in the Nylon aileron connector (steering arm) should be about 1/4" behind the ply nose gear mount, to the left of the nose block centerline. Lock the #4- 40 screw in this position. Tighten it very tight as it will be very difficult to re- tighten after the nose block is attached to the fuselage. Note that you can turn the nose gear further in one direction than you can in the other.

- ❑ 73. Remove the four sheet metal screws and lift off the nose gear assembly. Using a #11 Exacto blade, cut a wedge of balsa from the rear of the nose block to allow free turning of the steering arm when a right hand turn is needed (steering arm moves forward). Re- install the nose gear assembly, making sure you can turn the nose wheel at least 20° either side of center.

- ❑ 74. Find the 1/16" dia. x 12" music wire steering link. Bend one end of it as shown on sheet #2 of the plans. Insert it into the steering arm as shown.

- ❑ 75. Attach the nose block, with the nose gear and steering link installed, to the front of the fuselage with Sig slow C/A. You will have to provide a clearance notch in F- 5 for the steering link wire. This is shown in the top view of sheet #2 of the plans but it may vary depending on how your steering link is bent. If you are building the slope soaring Tri-Star, attach the nose block only, skipping the landing gear parts and steering link.

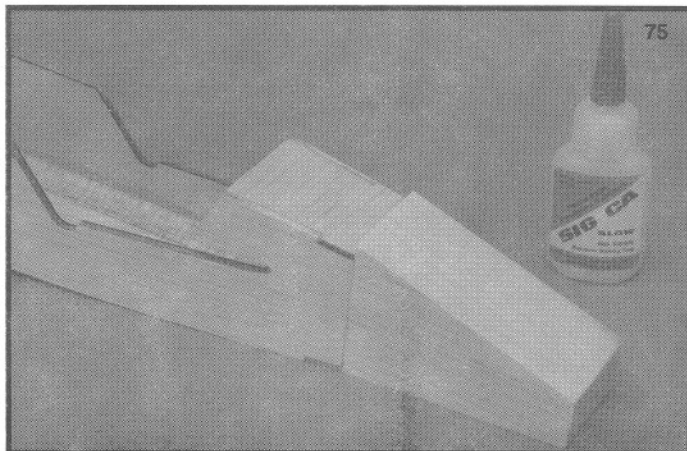

□ 76. Install the 1/8" x 3/8" x 1- 3/4" balsa fuselage cross brace as shown on the side view of the plan. It is located just above and to the rear of the canard hinge line. Use the plan to get the length exactly right.

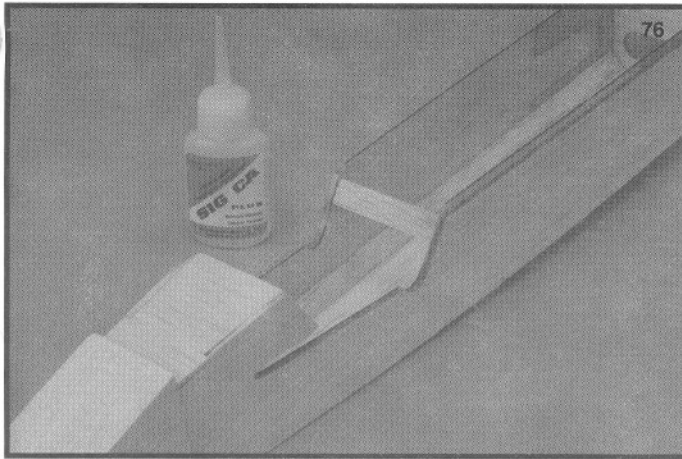

□ 77. Tightly tape the two hatch sides to the fuselage sides with masking tape. Install the CBF (canopy bulkhead, front), and CBR (canopy bulkhead, rear), to the underside of the 1/4" balsa triangle stock. In order to achieve the correct angle for these two parts, it will be necessary to trim away part of the 45° angles on CBF and CBR, that are glued to the triangle stock. Work slowly and carefully, using a sharp blade, or sanding block, for trimming. You will also have to provide a clearance notch in CBF to clear your steering link wire.

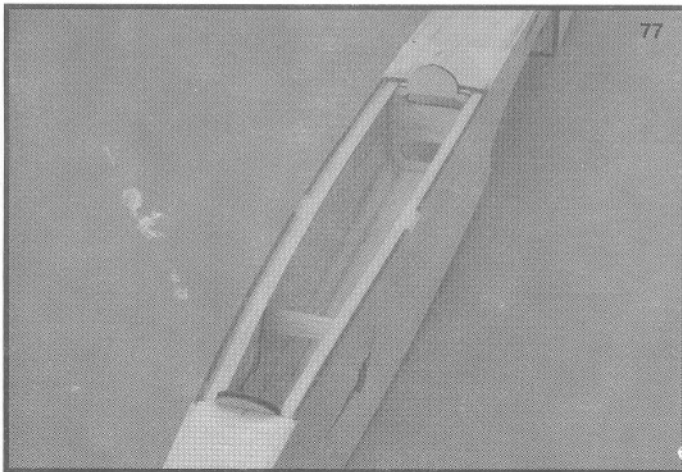

□ 78. Find and install the 3/32" balsa hatch base, using the tabs and notches for alignment. Use tape, or rubber bands to keep pressure to the parts while you apply the Sig Thin C/A to the joints.

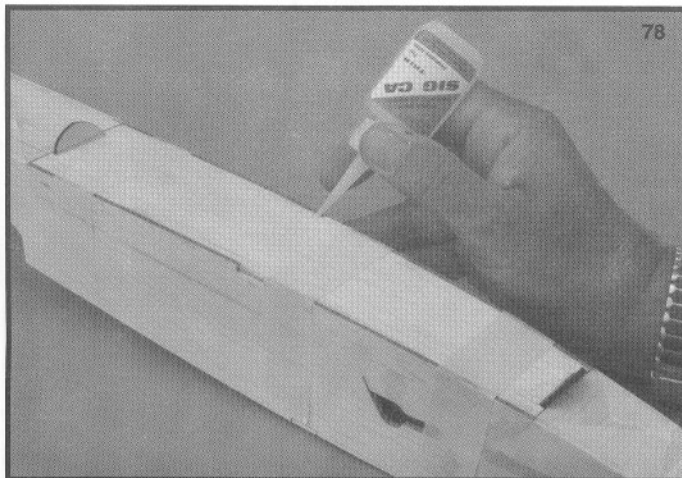

□ 79. Install the 5/16" square x 7/16 " long balsa hatch pin block as shown on the plan side view. Carefully taper the rear surface to match the angle of CBF before gluing it into position. **DO NOT** glue the block to CBF.

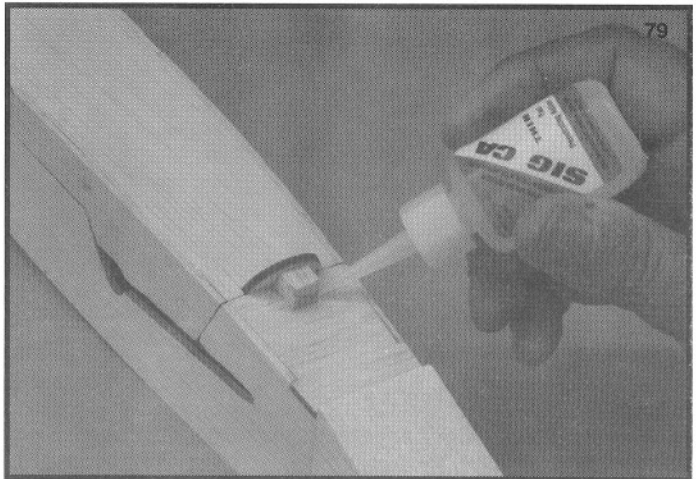

□ 80. Drill a 1/8" diameter hole through the 3/32" ply CBF. Continue drilling at least 5/16" deep into the 5/16" square canopy hatch pin block.

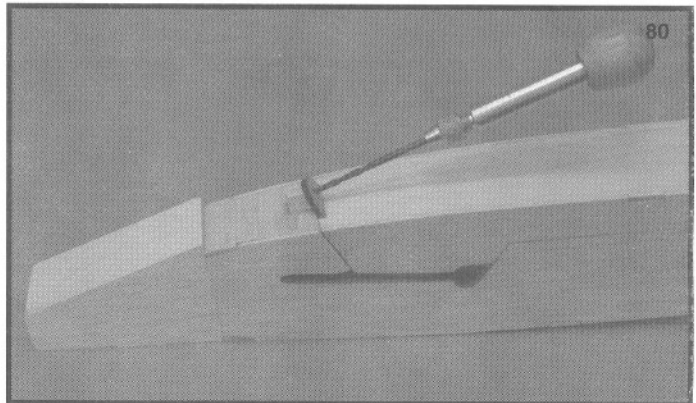

□ 81. Find the 1/8" diameter x 1/2" long birch dowel. Gently round both ends with sandpaper. Glue the 1/8" dowel into the 5/16" square block, making sure that at least 5/32" of it remains sticking out the slanted rear face of the block. Soak the block with Sig Thin C/A to "harden" it.

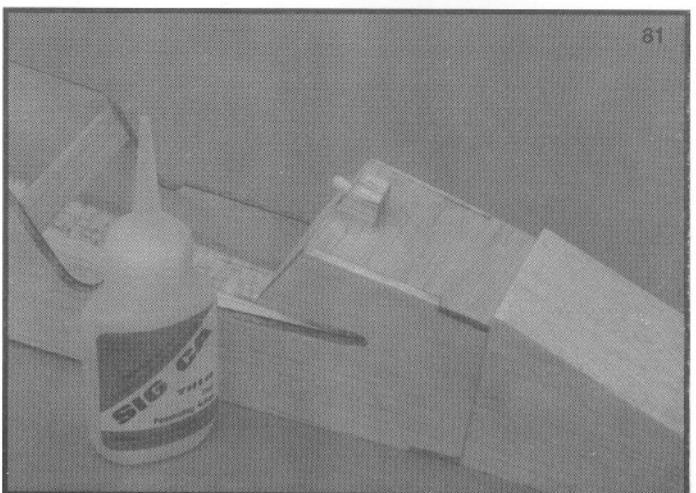

□ 82. From a paper clip, or a suitable pin, bend a hook such as is shown on the plan side view. This is used to attach the rubber band that holds down the rear of the hatch. Attach the hook with epoxy, and reinforce the joint with a small patch of fiberglass cloth.

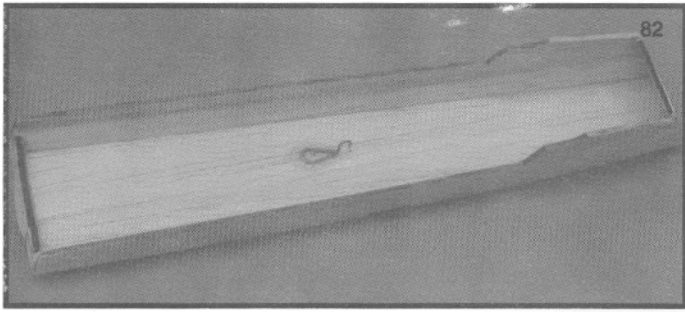

□ 83. Using your own Radio equipment as a guide, Install the 3/16 x 1/4 x 2 spruce servo rails. The front rails may need to be shortened slightly so as not to push the fuselage sides too far apart. Use the top view of the plan as a guide for the correct lengths. Attaching the spruce servo rail to the servo, and hooking up the aileron pushrods using the supplied connectors, will make locating the servo much easier. Slide the servo up and down, forward and aft, until a position is achieved where no binding occurs between the aileron pushrods and slots. Once this is achieved, lock the servo rail to the fuselage ply doubler with thin CA. Go over the joint with thick or medium CA to complete the rail installation. The elevator servo can be installed in the same manner.

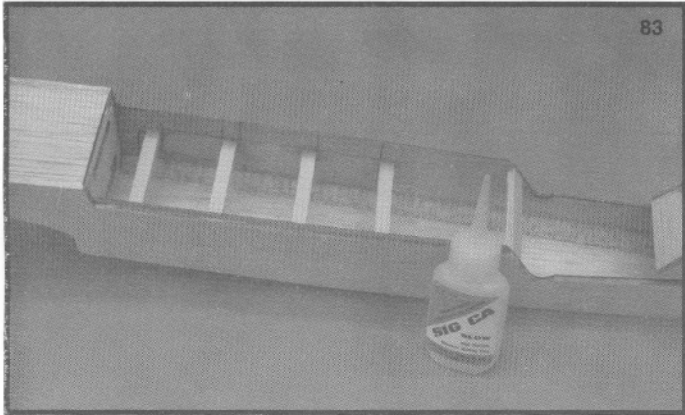

□ 84A. Using a sharp razor plane, or an Exacto carving blade, shape and round the fuselage corners. Attach the firewall to the F-1 bulkhead with four of the #2 sheet metal screws as reference for the proper corner radius. You will be able to see about 1/8" of the balsa triangle stock showing when the proper corner radius is achieved.

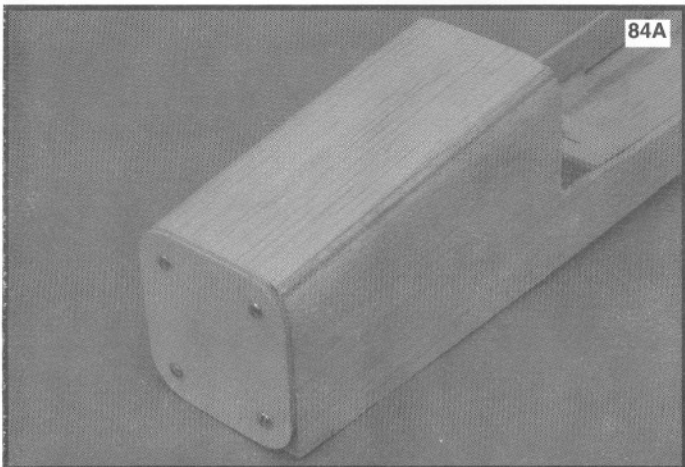

□ 84B. Carve, and sand the nose block to match the shape of the

fuselage, gradually changing the shape to round at the very nose of the ship. Finish up with a thorough sanding with 220 grit paper for a velvety smooth finish.

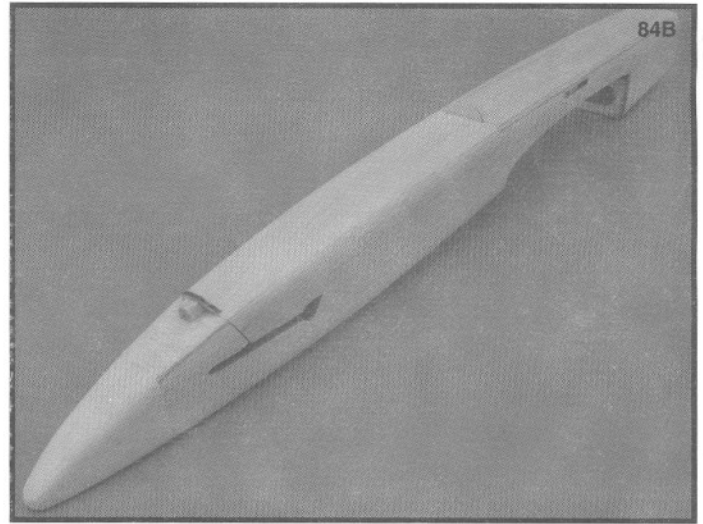

□ 85. The three, .030 clear canopy parts, have trim lines molded into them. These are to serve as a guide for trimming off the excess plastic. Use a sharp scissors to get close, then finish by careful trimming with a razor blade. Work slowly and check your fit often. On the Prototype models the canopy frames were painted on the inside surface of the canopy parts with Sig dope. This makes for a lifetime paint job.

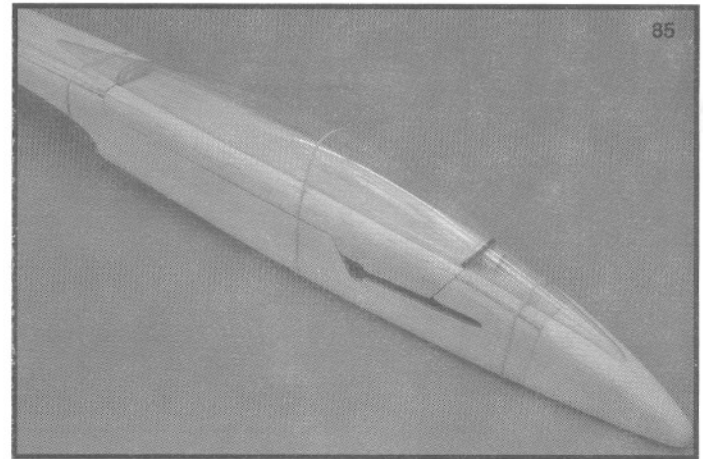

□ 86. If you want to add cockpit details, do so now. The Williams Brothers (1" scale) Military pilot figure will fit if you remove his head from the bust, just below his chin. Small pieces of balsa can be used to construct a headrest, or instrument panel. Please remember that no matter what details you add, KEEP THEM LIGHT. Be sure to paint, or cover the area that will be inside the main cockpit. Hold the main canopy section in place and draw a line around it with a soft pencil as a reference for the inside of the cockpit.

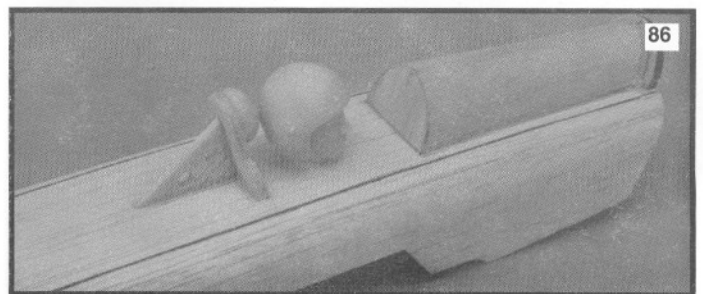

□ 87A. The molded ABS belly pan also has trim lines molded into its INSIDE surfaces. Because the belly pan material is thick, the trim lines will be fainter on the outside of the part than on the inside. Holding the part so that light can reflect off the inside surface can make the trim lines easier to see. Carefully trace around these trim lines with a fine tip felt pen. Study the plan, and refer to the photo to be sure you understand the shape of the finished part before you begin cutting.

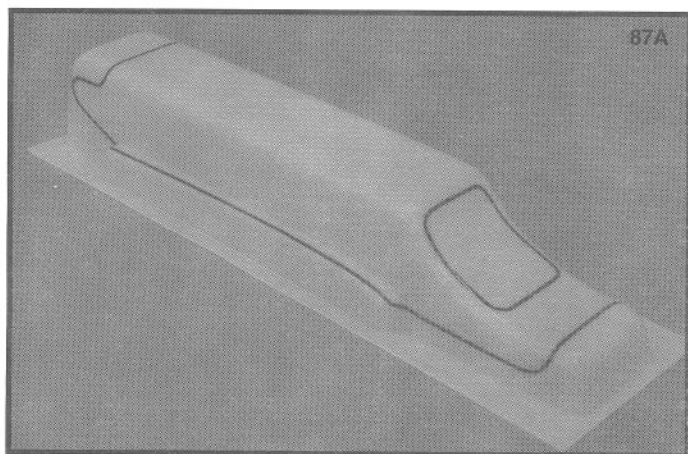

□ 87B. For the glow version, or slope soarer, you may choose to NOT cut out the air scoop opening, but merely paint it on instead. This will reduce drag slightly and reduce the chance of dirt getting into your throttle servo. For the Electric version however, you MUST cut out the air scoop to properly cool the battery pack and motor/ speed control.

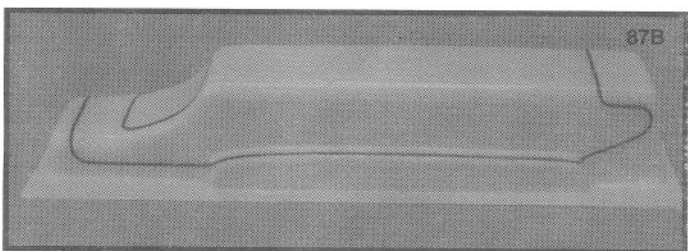

□ 88. Using a razor saw, or coping saw, and an Exacto knife, carefully trim the excess material from the belly pan. Cut all the straight lines with the razor saw, and the curved lines with the coping saw. Work carefully, holding the belly pan to the fuselage often to check progress. Final sand the edges with a sanding stick and a sandpaper covered dowel 1/2" in diameter.

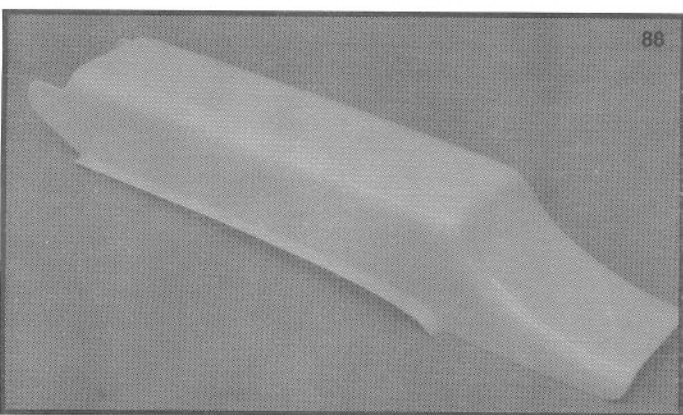

NOTE: IF YOU ARE BUILDING THE SLOPE SOARING VERSION OF TRI- STAR, SKIP TO STEP 92.

□ 89. Find the 3/32" x 1- 5/8" x 2" ply main gear doubler. Using the full size drilling guide included on plan sheet #2, Mark, and drill the six 3/32" dia. holes.

□ 90. Tape the ply piece onto the bottom of the belly pan where shown on sheet #2 of the plans. With the same 3/32" dia. drill, drill through the belly pan bottom, using the ply piece as a drill guide.

□ 91. Scuff up the inside of the bottom of the belly pan, and glue the main gear doubler to the inside surface, using Sig slow C/A, or Epoxy. Be sure the holes remain in alignment and are not filled with glue.

□ 92. With the fuselage laying upside- down on a stable work surface, cover the bottom surface of the two wing bolt plates with one layer of masking tape. Place the wing into the wing saddle. (Bottom side up please). Center the wing in the fuselage and make sure the wing is straight by measuring from the front corner of each wing tip to the center of the nose, as shown in the diagram below.

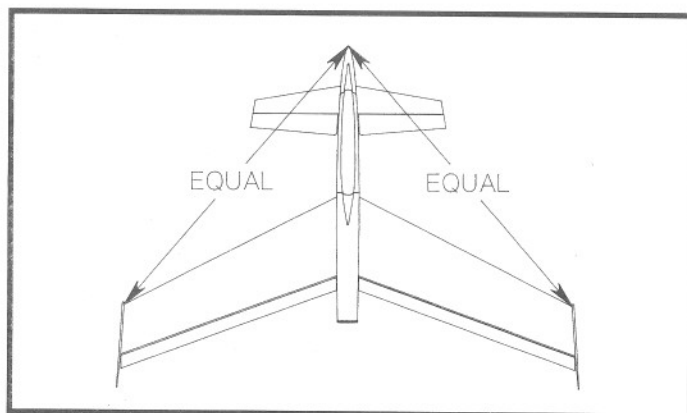

These two measurements must be equal. Once you are confident the wing is properly centered, and straight, hold it in position with two rubber bands as shown in the photo.

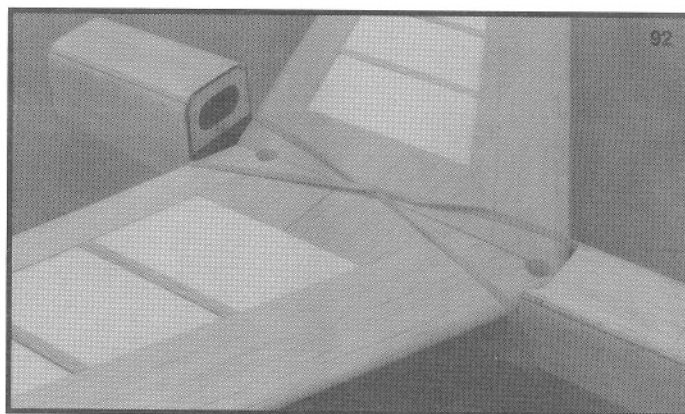

□ 93. Find the two, 1/2" diameter wing dowels. One is 5/8" long and the other is 7/8" long. Drill a 7/32" diameter hole, lengthwise, through the center of each dowel. This is best done on a drill press.

□ 94. Using the corner of a sanding block, lightly "NICK" the outside diameter of each dowel in several places along its length.

□ 95. Mix up some slow set epoxy, and, using the mixing stick, coat the inside surface of the two 1/2" diameter holes on the wing. Also lightly coat the outside diameter of the two wing dowels.

□ 96. Press and twist the 7/8" long dowel into the hole at the front of the wing. Press it down through the hole until its end touches the taped surface of the front wing bolt plate. Repeat with the rear, 5/8" long dowel. Leave this assembly alone for about an hour so it gets a chance to harden thoroughly.

□ 97. Before you remove the wing assembly from the fuselage, use your 7/32" diameter drill to carefully mark the starting position for the #10- 32 wing bolt holes. **Do this by twisting the drill by hand.** You need to drill through the masking tape and get a sharp, center position mark on the wing bolt plates below the wing dowels. Don't drill any deeper than necessary to do that.

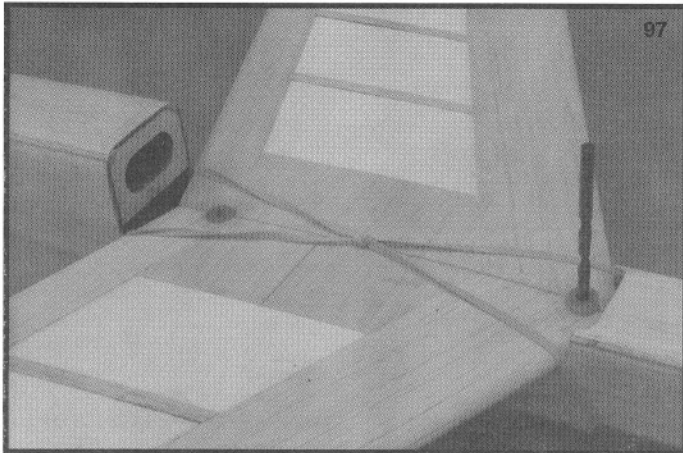

□ 98. Remove the wing from the fuselage and carefully cut, or sand away any excess epoxy that may have leaked onto the wing surface while installing the two dowels. Remove the Masking Tape from the wing bolt plates.

□ 99. At the center positions you marked in step 97, drill a #21 (.159) diameter hole through each wing bolt plate. Tap these holes with a # 10- 32 tap. Place a drop of thin C/A into each completed thread and allow to thoroughly cure. Then, carefully re- tap the hole. This will result in a tight, long lasting thread in the plywood wing bolt plate.

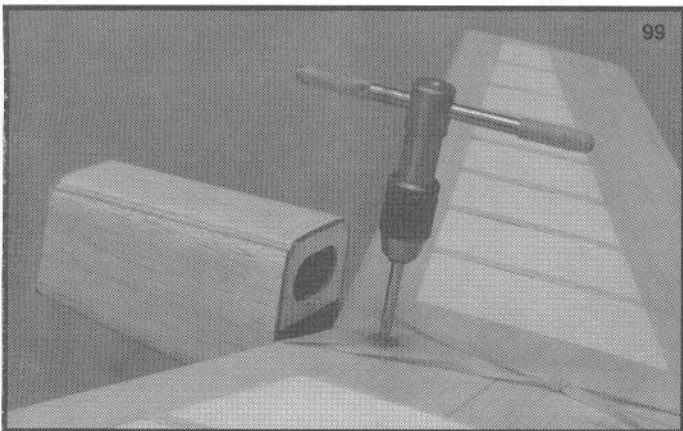

□ 100. With the wing firmly bolted in position, place the plastic belly pan over the bottom of the wing. Slide it forward or back to achieve the best fit between the bottom of the wing and the wing flanges on the belly pan. There WILL be a gap between the wing and belly pan which will be filled later by the wing seat tape. When satisfied that the fit is correct, tape the belly pan tightly to the fuselage with masking tape.

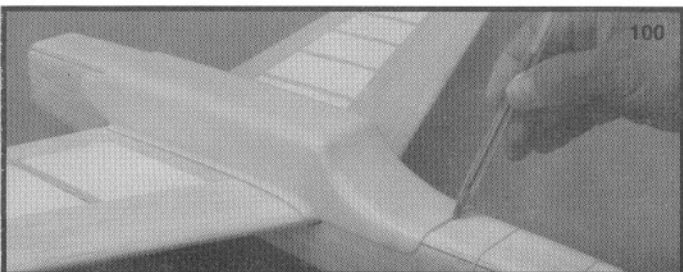

□ 101. Locate the three, 3/16" x 1/2" x 3/4" ply belly pan blocks. Draw an "X" on each by making a pencil line from corner to corner. Drill a 5/32" diameter hole through each ply plate at the center of the "X". Locate the three #4- 40 blind nuts. Using a small hammer, tap a blind nut into each block, and secure it with C/A.

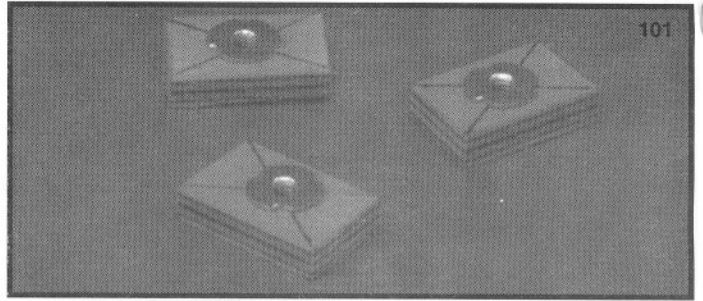

□ 102. At the rear of the Plastic Belly Pan are two Nylon Screws that serve as Hinge points for the drop down Belly Pan. At the center of the radius on the belly pan ear, drill a 1/8" diameter hole through the Belly Pan Ear, and the fuselage side. Do this on both sides of the fuselage. Drill a third 1/8" diameter hole through the belly Pan and Fuselage BOTTOM where indicated, just below the aileron and elevator servo locations. This is the Belly Pan Lock Screw location. **Remove the belly pan and wing from the fuselage.**

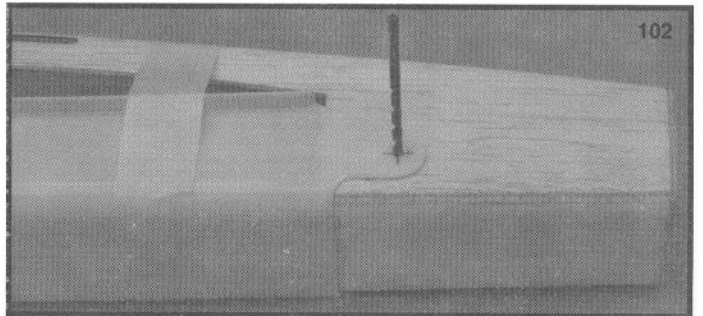

□ 103. Using one of the #4- 40 nylon bolts provided, attach the ply plate (with blind nut) to the inside of the fuselage **bottom**. The 3/4" dimension of the ply plate goes "across" the fuselage. Put a single "Dot" of Sig Medium C/A at each corner of the ply plate to locate and hold it. Remove the nylon bolt, and apply Sig Thin C/A to the joint between the plate and the bottom of the fuselage. Lastly, apply a bead of Sig Medium C/A around the entire perimeter of the ply plate. Repeat this process for the two Ply plates at the Belly Pan pivot points.

□ 104. Find the three, 1/8" brass eyelets. Press one into each of the three 1/8" holes from the outside of the belly pan. Secure them in position with a drop of medium C/A. Harden the three, 1/8" diameter holes drilled through the fuselage sides by soaking with thin C/A. **NOTE: Don't get the C/A in the threads in the blind nuts.**

□ 105. Cut the 2" x 18" fiberglass tape into two equal parts. Lightly spray one side of each piece with the 3M 77 spray. Apply one piece of the glass tape to the bottom of the wing center section, using a new, #11 Exacto blade to cut an "X" that will allow the glass tape to fit down over the wing bolt dowels. Use your fingers to smooth the glass cloth into place over everything.

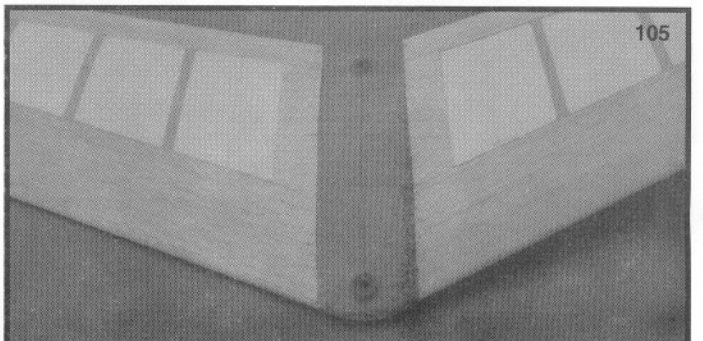

□ 106. Repeat the last part of the previous step on the top side of the wing.

□ 107. Apply thin, foam friendly C/A, or epoxy, to the glass cloth by covering your finger with waxed paper and rubbing the glue into the cloth until it is thoroughly "Wetted". When through, and the glue is completely hardened, sand both sides of the center section with 220 grit sandpaper to remove any rough edges. Be careful not to sand through the thin wing sheeting.

□ 108. Cut the ends of the two, 1/4" x 1- 1/4" balsa ailerons to the correct angle, using the plan sheet as a guide.

BUILDERS TIP: SINCE THE WING IS THINNER AT THE TIP THAN AT THE ROOT, SO IS THE TRAILING EDGE. YOU MAY WANT TO USE A RAZOR PLANE AND SANDING BLOCK TO TAPER EACH AILERON TO MATCH THE THICKNESS OF WING TRAILING EDGE.

□ 109. Read the section marked "Installing Easy Hinges", just after step 135, before doing the following. Then, mark the location of the Sig Easy hinges, on the wing, ailerons, canard, and elevators. Carefully cut the slots for the hinges, using a sharp, #11 Exacto blade. **DO NOT INSTALL THE HINGES AT THIS TIME.**

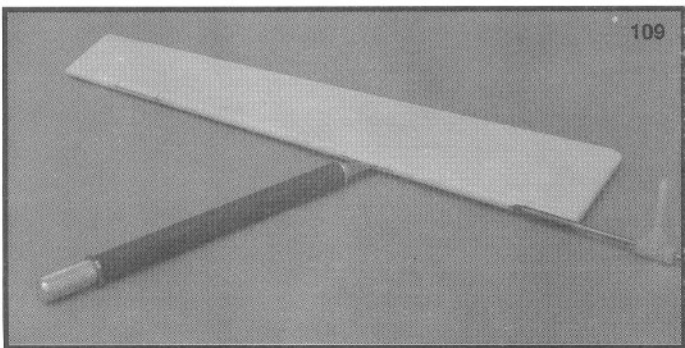

□ 110. Wash the belly pan thoroughly with soap and water. Sand the outside with #400 or finer, wet or dry sandpaper. Paint the belly pan to match your chosen color scheme. All of the prototype Tri- Stars were painted using Sig Supercoat dope. Once the belly pan is painted and is thoroughly dry, Install the main landing gear using the three nylon clips and the mounting hardware provided.

□ 111. Install the aileron control horns, using the #2- 56 round headed screws provided. Locate them as shown on the plan sheet.

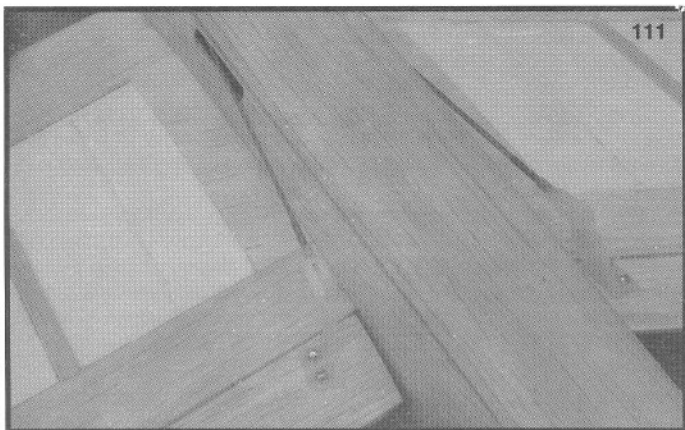

□ 112. Temporarily install the Sig Easy Hinges in the canard, **WITHOUT ANY ADHESIVE**. Slip the canard into the fuselage and center it. Mark where the edge of the fuselage meets the canard, top and bottom. These lines will be used to show where the covering will be removed later, so that the canard can be glued to the fuselage.

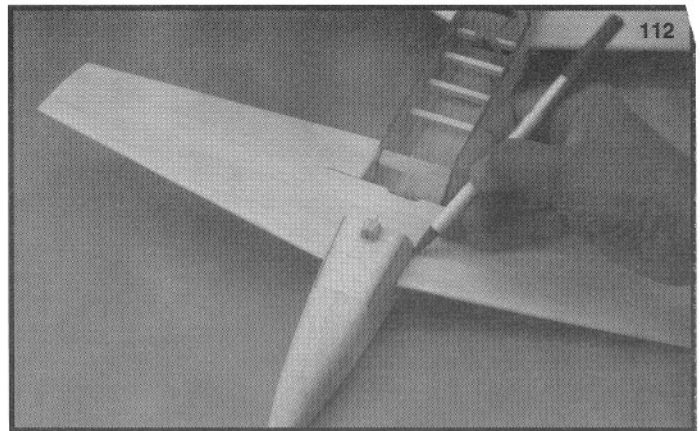

□ 113. Install the 1/16" x 1/4" wing seating tape to the flanges on the plastic belly pan where they will contact the bottom of the wing.

□ 114A. Install the 3/32" x 1" x 2- 1/8" balsa Belly Pan cross brace between the two sides of the Belly Pan. Locate it as shown in the fuselage side view, almost directly below the C/G markers. This piece keeps the Belly Pan sides from Squeezing together.

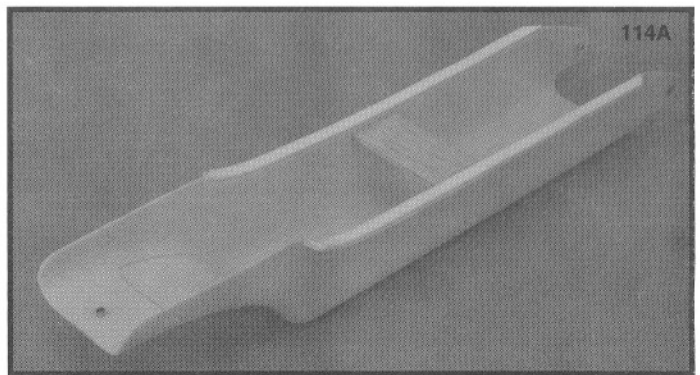

Then, install the plastic Belly Pan, using the three #4- 40 Nylon screws provided. You'll have to slightly stretch the belly pan pivot tabs apart to get the brass eyelets into the 1/8" holes in the fuselage sides. Once the belly pan is mounted, the two rear screws become the pivot point of a "Hinge", so all you'll ever have to do to change Batteries in your electric, or ballast in your slope glider, is to remove the front nylon screw and hinge the belly pan downward.

□ 114B. Finish hooking up the control linkages. You will have to shorten the #2- 56 threaded rod that operates the elevator. The ones used for the ailerons will work as provided if you installed your aileron servo as shown.

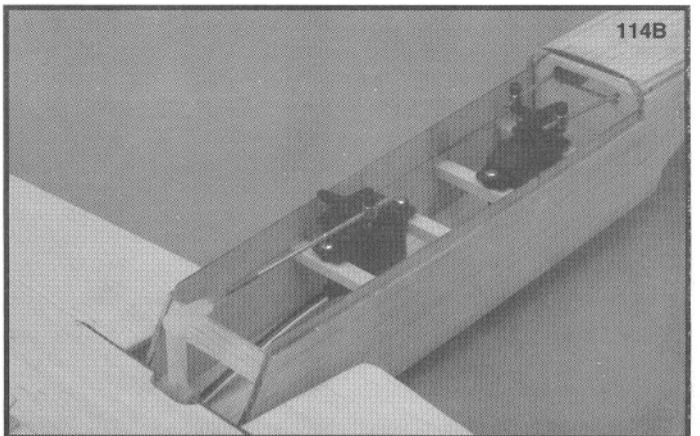

CAUTION: A word about canard control hookups. If you are standing **BEHIND** the airplane, and move the aileron stick to the right, signalling for a right hand turn, the right aileron will go **UP**, and the left aileron will go **DOWN**. The opposite occurs when you signal for a left hand turn. This is the same as for all other aileron/elevator airplanes. **HOWEVER**, when you pull the stick back toward you, signalling for **UP ELEVATOR**, the elevator trailing edge **MUST MOVE DOWNWARD**. If it does not, **YOU WILL CRASH!!!**

□ 115. There are differences in the firewall for the glow, electric, or slope versions. The three options are described below;

□ 116. **Slope:** All that is necessary for the slope firewall is to attach the tail cone mounting tabs, and provide a hole large enough to pass your battery pack connector through. Locate the tabs as shown on the left end of the plan sheet. Set them in about 1/32" from flush with the sides of the firewall so that the mounted tail cone will be flush with the right, and left sides of the finished fuselage. Study the slant on the sides of the tail cone, and lean the tabs inward an appropriate amount to achieve a good fit. Trim the flange from the rear face of the tail cone so it mounts as shown on the plan and attach it with two of the #2 sheet metal screws provided.

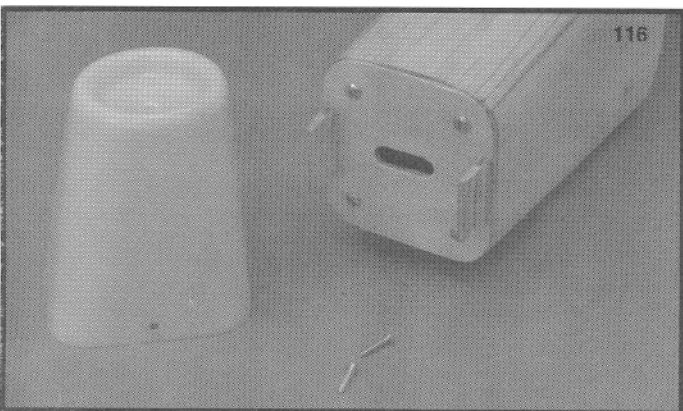

□ 117. **Electric:** Draw a line, in an "X" form, from the four corner holes in the firewall. Drill, and file a hole, centered on the "X", to fit the mounting shoulder on your electric motor. Most are 1/2" in diameter, but check your motor to be sure. Locate and drill the motor mounting holes for your motor. Also, drill four cooling holes to match the ones on your motor. Mount your motor with the appropriate screws.

Our speed controls were mounted, using Velcro, to the floor of the compartment just in front of the electric motor. Soaking the floor with thin C/A helps provide a good base for the "Self-Stick" variety of Velcro. A diagram is provided in this manual that shows a typical electric drive system installation. Be sure to reverse the motor rotational direction as shown on the diagram, or, if your motor includes directions for reversing rotation, use those. Install the prop (**tractor type**) so that the front of the blades face the front of the plane. If you use the GM type fuse and fuse holder, it will double as an arming switch. Simply mount the fuse holder in the side of the fuselage in a convenient spot where you can plug the fuse into it when you are ready to fly. With the fuse removed, the whole motor system is disarmed.

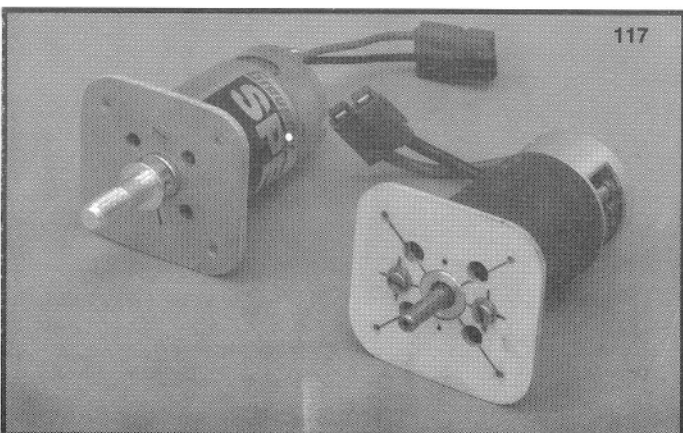

DANGER-WARNING: Important! Read These Warnings.

Model electric motors are very powerful and the props are very sharp. Be extra cautious around electric airplanes so eye or hand injuries are avoided. Always use a fuse in the wiring system to avoid fire from overheated wires or batteries.

□ 118. **Glow:** Since there are many .09 to .15 engines that can be mounted on the Tri-Star firewall, you will need to obtain a nylon mount to match your choice of engine. Dave Brown mounts were used on the prototypes. Obtain the necessary blind nuts and screws to attach your mount to the firewall, and to attach your engine to the mount. Don't forget to drill clearance holes for the fuel lines and the throttle cable tube. Paint the firewall with fuel proof dope.

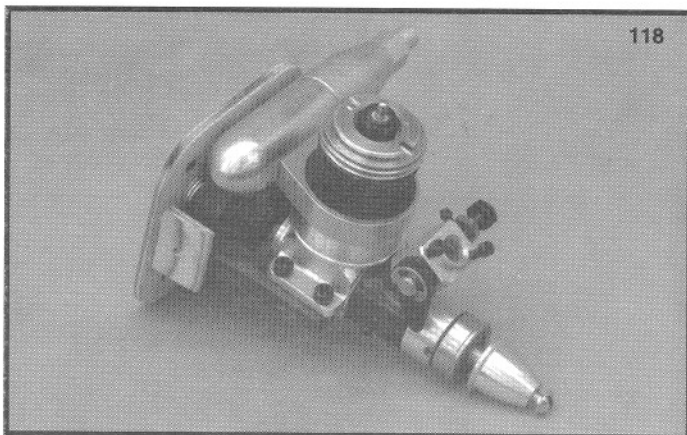

A typical fuel tank installation, and engine installation is shown in detail in the center-fold of this manual. A 2 oz. round tank was used with the .09 engine prototypes. A 4 oz. rectangular Flex tank was installed through the optional hatch arrangement for the .15 size engine models. Trim the rear face of the ABS tail cone/cowl piece to get the proper distance from firewall to the front of the prop, and to assure the correct mounting angle. If you choose to mount the Cox .09 R/C such as we did, you will have to space the Dave Brown mount away from the firewall with washers to get a small gap between the muffler and the firewall if you rotate the muffler as we did. You will also have to trim the top of the mount slightly. Lastly, cut out the top of the ABS cowl to fit around the engine you have chosen.

Pusher props are required for the glow version of Tri-Star. Tractor props mounted backwards **WILL NOT WORK**. Mount the pusher prop with the curved side of the blade toward the front of the airplane. If the prop has a decal on it, this goes to the front of the airplane.

DANGER-WARNING: Important! Read These Warnings.

A model airplane motor gets very hot and can cause serious burns. Do not touch the motor during or after operation. Keep clear of the propeller, it can cut off a finger or put out an eye. Make sure the prop is securely fastened in place and is not cracked. Model airplane fuel is flammable and poisonous. Take the same precautions while transporting and using it that you would with a can of gasoline or a bottle of poison.

Remember that it is possible to lose control of a model airplane. Do not fly in locations where the model may hit people or damage property if a loss of control occurs. Check your model and equipment regularly to insure it is in safe operating condition.

- 119. For the glow version, install the throttle servo to the inside, bottom of the belly pan with some of the 1/16" x 1/2" servo tape, as shown on the plan side view. Clean the inside surface of the belly pan first with alcohol to get a good bond with the servo tape. The servo mounts immediately in front of the main gear doubler plate.

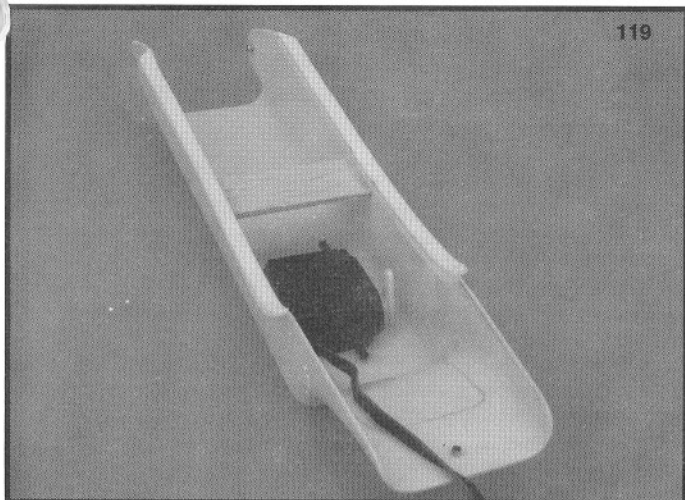

- 120. Solder the #2- 56 size solder link to one end of the 1/16" diameter flex throttle cable. Solder the opposite end of the cable to "Stiffen" it.

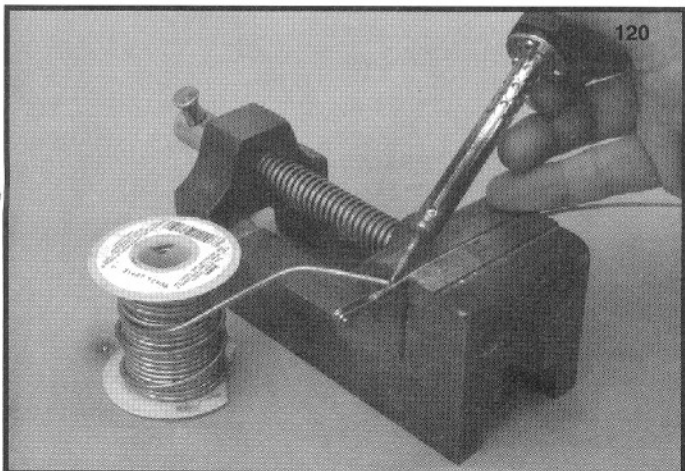

- 121. Find the 1/8" dia x 9- 5/8" plastic throttle cable tube. Sand the outside of it with 180 grit sandpaper. Slide the tube into position in the hole in the firewall. Thread it forward into the cavity below the wing. Next, thread the flex cable into the forward end of the tube. Attach the solder link to the servo arm as shown in the fuselage side view. As you close the belly pan the cable will follow the tube into the engine area.

- 122. Attach one of the Sig pushrod connectors to your engine throttle arm, using the plastic push nut provided. By carefully opening and closing the belly pan, you can thread the rear end of the flex cable into the throttle pushrod connector.

Dear Kit Builder:

We want to have the instructions for building this model as clear as possible. The real test is whether you can understand them easily. If you do not, write or call us on the Sig Modeler's Hotline, 800-524-7805 (weekdays, 7:00 am - 4:30 pm Central) and tell us what parts (steps) were difficult to interpret. Any suggestions or comments about how the model builds and flies will be greatly appreciated.

Sincerely,
LeRoy Satterlee, Product Engineer
 Sig Manufacturing Co., Inc.

- 123. Slide the plastic tube back and forth until you are sure there is adequate operating space for the servo arm and the engine throttle arm. Trim the length of the plastic tube if necessary. Fix it in position at the firewall with a dab of epoxy. If you remove the engine later, do so by removing firewall and all. This way the throttle cable tube will come off with the engine.

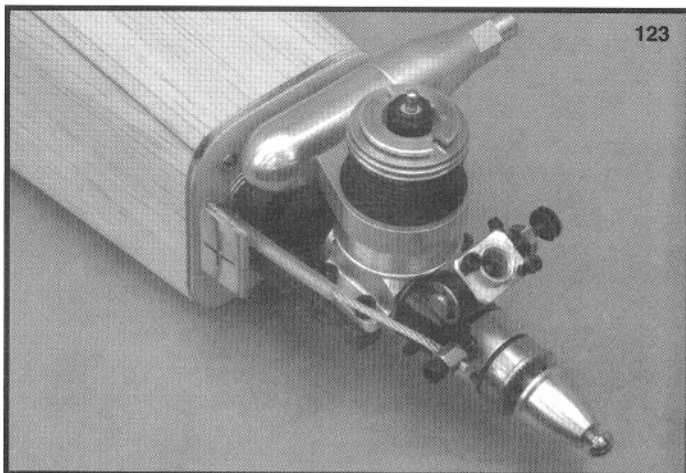

- 124. Take everything apart at this point in preparation for covering. One final sanding of all of the parts, including the tail cone and the belly pan, with #320 sandpaper will give you a velvety smooth airplane.

- 125. Vacuum the parts, using an attachment with a soft brush on the end. When through, wipe the whole plane down with a "Tack" cloth obtained from a paint store.

SELECT A COVERING.

All of the Tri- Star prototypes were covered with Sig Supercoat Iron-on plastic covering. All trimming was done with Sig Supertrim Self-Stick trim sheets and a selection from the 4 decal sheets provided.

It is important that you choose a LOW TEMPERATURE covering material so you don't melt the foam wing core under the thin 1/32" sheeting.

IN ALL CASES, FOLLOW THE INSTRUCTIONS ON THE COVERING MATERIAL YOU SELECT.

COVERING.

- 126. Start by covering the Wing Fins. Cover the inside surfaces first, followed by the outside surfaces. Cut out the covering material where the wing fin will join the wing tip. Use the template provided as a guide. It is the same template as used in step #7.

- 127. Cover the Canard fixed surface, bottom first, and then top. Remove the material where the canard will be glued to the fuselage later, on both the bottom and the top surfaces of the canard.

- 128. Cover the elevators next, Bottom first, and then the top.

- 129. Cover the wing, in halves, bottom first, and top last. Be careful with the heat on the wing so you don't destroy the adhesive bonds or melt the foam through the thin 1/32" balsa sheeting.

- 130. Cover the fuselage next. Cover the surfaces in the following sequence. Fuselage sides, Bottom rear, Bottom front, Top rear, Top front, Hatch sides, Hatch top.

- 131. Do your decorating before you assemble the ship. The parts are easier to handle. If you don't like any of the trim schemes represented on the kit label, a drawing has been provided in the center of the manual so you can sketch your own ideas. Run copies on a copier and sketch your ideas on the copies.

CAUTION: A word about canard control hookups. If you are standing **BEHIND** the airplane, and move the aileron stick to the right, signalling for a right hand turn, the right aileron will go **UP**, and the left aileron will go **DOWN**. The opposite occurs when you signal for a left hand turn. This is the same as for all other aileron/elevator airplanes. **HOWEVER**, when you pull the stick back toward you, signalling for **UP ELEVATOR**, the elevator trailing edge **MUST MOVE DOWNWARD**. If it does not, **YOU WILL CRASH!!!**

□ 115. There are differences in the firewall for the glow, electric, or slope versions. The three options are described below;

□ 116. **Slope:** All that is necessary for the slope firewall is to attach the tail cone mounting tabs, and provide a hole large enough to pass your battery pack connector through. Locate the tabs as shown on the left end of the plan sheet. Set them in about 1/32" from flush with the sides of the firewall so that the mounted tail cone will be flush with the right, and left sides of the finished fuselage. Study the slant on the sides of the tail cone, and lean the tabs inward an appropriate amount to achieve a good fit. Trim the flange from the rear face of the tail cone so it mounts as shown on the plan and attach it with two of the #2 sheet metal screws provided.

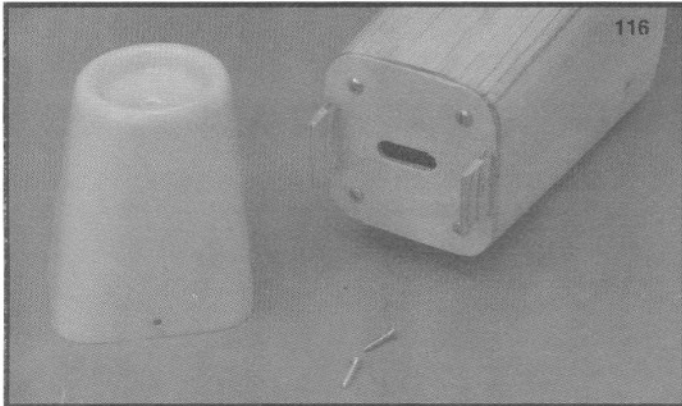

□ 117. **Electric:** Draw a line, in an "X" form, from the four corner holes in the firewall. Drill, and file a hole, centered on the "X", to fit the mounting shoulder on your electric motor. Most are 1/2" in diameter, but check your motor to be sure. Locate and drill the motor mounting holes for your motor. Also, drill four cooling holes to match the ones on your motor. Mount your motor with the appropriate screws.

Our speed controls were mounted, using Velcro, to the floor of the compartment just in front of the electric motor. Soaking the floor with thin C/A helps provide a good base for the "Self-Stick" variety of Velcro. A diagram is provided in this manual that shows a typical electric drive system installation. Be sure to reverse the motor rotational direction as shown on the diagram, or, if your motor includes directions for reversing rotation, use those. Install the prop (**tractor type**) so that the front of the blades face the front of the plane. If you use the GM type fuse and fuse holder, it will double as an arming switch. Simply mount the fuse holder in the side of the fuselage in a convenient spot where you can plug the fuse into it when you are ready to fly. With the fuse removed, the whole motor system is disarmed.

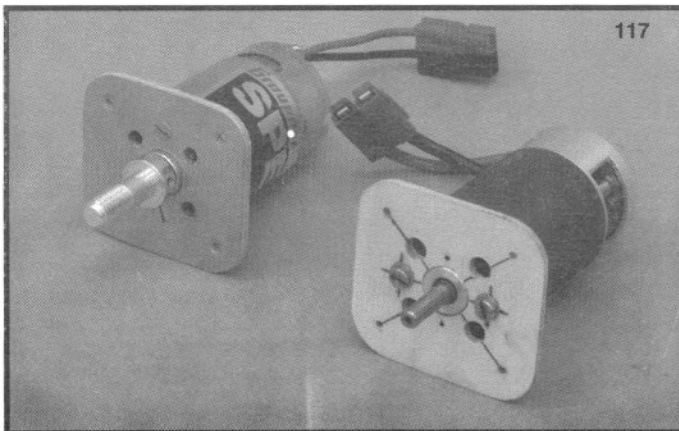

DANGER-WARNING: Important! Read These Warnings.

Model electric motors are very powerful and the props are very sharp. Be extra cautious around electric airplanes so eye or hand injuries are avoided. Always use a fuse in the wiring system to avoid fire from overheated wires or batteries.

□ 118. **Glow:** Since there are many .09 to .15 engines that can be mounted on the Tri-Star firewall, you will need to obtain a nylon mount to match your choice of engine. Dave Brown mounts were used on the prototypes. Obtain the necessary blind nuts and screws to attach your mount to the firewall, and to attach your engine to the mount. Don't forget to drill clearance holes for the fuel lines and the throttle cable tube. Paint the firewall with fuel proof dope.



A typical fuel tank installation, and engine installation is shown in detail in the center-fold of this manual. A 2 oz. round tank was used with the .09 engine prototypes. A 4 oz. rectangular Flex tank was installed through the optional hatch arrangement for the .15 size engine models. Trim the rear face of the ABS tail cone/cowl piece to get the proper distance from firewall to the front of the prop, and to assure the correct mounting angle. If you choose to mount the Cox .09 R/C such as we did, you will have to space the Dave Brown mount away from the firewall with washers to get a small gap between the muffler and the firewall if you rotate the muffler as we did. You will also have to trim the top of the mount slightly. Lastly, cut out the top of the ABS cowl to fit around the engine you have chosen.

Pusher props are required for the glow version of Tri-Star. Tractor props mounted backwards **WILL NOT WORK**. Mount the pusher prop with the curved side of the blade toward the front of the airplane. If the prop has a decal on it, this goes to the front of the airplane.

DANGER-WARNING: Important! Read These Warnings.

A model airplane motor gets very hot and can cause serious burns. Do not touch the motor during or after operation. Keep clear of the propeller, it can cut off a finger or put out an eye. Make sure the prop is securely fastened in place and is not cracked. Model airplane fuel is flammable and poisonous. Take the same precautions while transporting and using it that you would with a can of gasoline or a bottle of poison.

Remember that it is possible to lose control of a model airplane. Do not fly in locations where the model may hit people or damage property if a loss of control occurs. Check your model and equipment regularly to insure it is in safe operating condition.

□ 119. For the glow version, install the throttle servo to the inside, bottom of the belly pan with some of the 1/16" x 1/2" servo tape, as shown on the plan side view. Clean the inside surface of the belly pan first with alcohol to get a good bond with the servo tape. The servo mounts immediately in front of the main gear doubler plate.

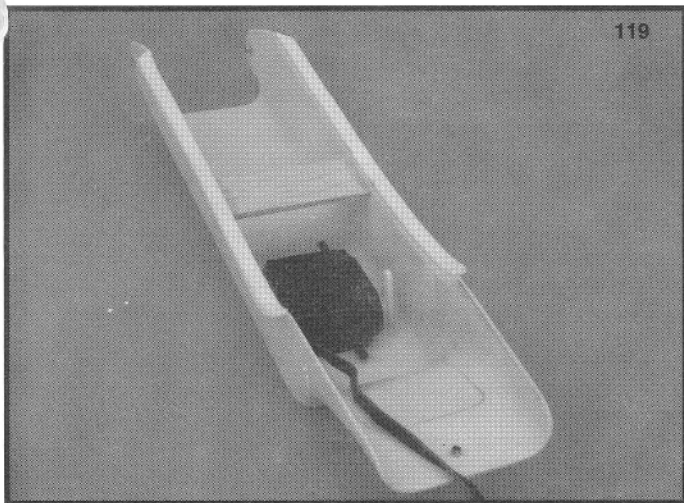

□ 120. Solder the #2- 56 size solder link to one end of the 1/16" diameter flex throttle cable. Solder the opposite end of the cable to "Stiffen" it.

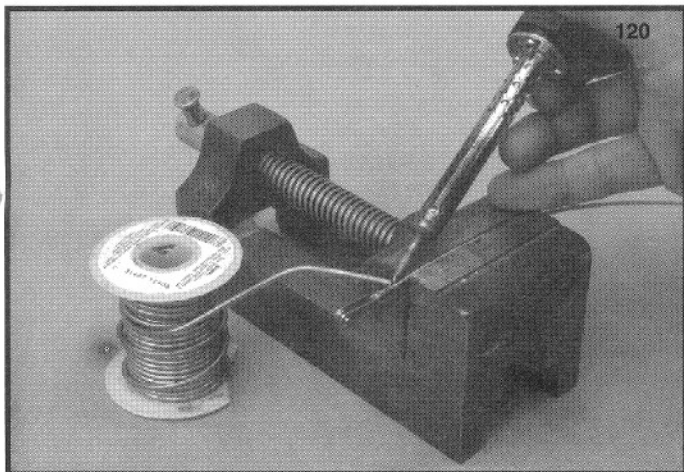

□ 121. Find the 1/8" dia x 9- 5/8" plastic throttle cable tube. Sand the outside of it with 180 grit sandpaper. Slide the tube into position in the hole in the firewall. Thread it forward into the cavity below the wing. Next, thread the flex cable into the forward end of the tube. Attach the solder link to the servo arm as shown in the fuselage side view. As you close the belly pan the cable will follow the tube into the engine area.

□ 122. Attach one of the Sig pushrod connectors to your engine throttle arm, using the plastic push nut provided. By carefully opening and closing the belly pan, you can thread the rear end of the flex cable into the throttle pushrod connector.

Dear Kit Builder:

We want to have the instructions for building this model as clear as possible. The real test is whether you can understand them easily. If you do not, write or call us on the Sig Modeler's Hotline, 800-524-7805 (weekdays, 7:00 am - 4:30 pm Central) and tell us what parts (steps) were difficult to interpret. Any suggestions or comments about how the model builds and flies will be greatly appreciated.

Sincerely,
 LeRoy Satterlee, Product Engineer
 Sig Manufacturing Co., Inc.

□ 123. Slide the plastic tube back and forth until you are sure there is adequate operating space for the servo arm and the engine throttle arm. Trim the length of the plastic tube if necessary. Fix it in position at the firewall with a dab of epoxy. If you remove the engine later, do so by removing firewall and all. This way the throttle cable tube will come off with the engine.

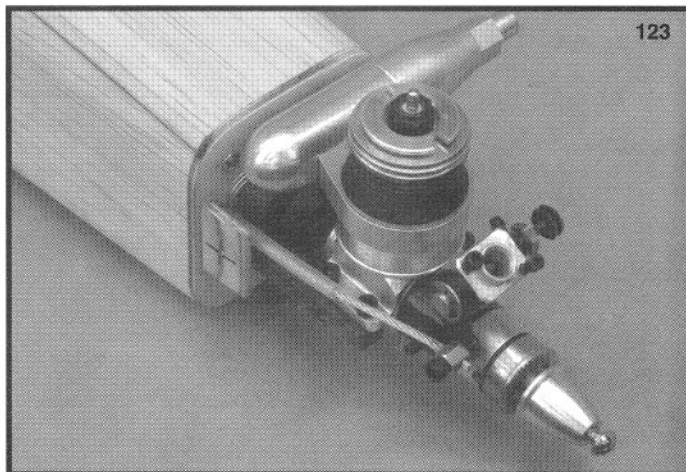

□ 124. Take everything apart at this point in preparation for covering. One final sanding of all of the parts, including the tail cone and the belly pan, with #320 sandpaper will give you a velvety smooth airplane.

□ 125. Vacuum the parts, using an attachment with a soft brush on the end. When through, wipe the whole plane down with a "Tack" cloth obtained from a paint store.

SELECT A COVERING.

All of the Tri- Star prototypes were covered with Sig Supercoat Iron-on plastic covering. All trimming was done with Sig Supertrim Self-Stick trim sheets and a selection from the 4 decal sheets provided.

It is important that you choose a LOW TEMPERATURE covering material so you don't melt the foam wing core under the thin 1/32" sheeting.

IN ALL CASES, FOLLOW THE INSTRUCTIONS ON THE COVERING MATERIAL YOU SELECT.

COVERING.

□ 126. Start by covering the Wing Fins. Cover the inside surfaces first, followed by the outside surfaces. Cut out the covering material where the wing fin will join the wing tip. Use the template provided as a guide. It is the same template as used in step #7.

□ 127. Cover the Canard fixed surface, bottom first, and then top. Remove the material where the canard will be glued to the fuselage later, on both the bottom and the top surfaces of the canard.

□ 128. Cover the elevators next, Bottom first, and then the top.

□ 129. Cover the wing, in halves, bottom first, and top last. Be careful with the heat on the wing so you don't destroy the adhesive bonds or melt the foam through the thin 1/32" balsa sheeting.

□ 130. Cover the fuselage next. Cover the surfaces in the following sequence. Fuselage sides, Bottom rear, Bottom front, Top rear, Top front, Hatch sides, Hatch top.

□ 131. Do your decorating before you assemble the ship. The parts are easier to handle. If you don't like any of the trim schemes represented on the kit label, a drawing has been provided in the center of the manual so you can sketch your own ideas. Run copies on a copier and sketch your ideas on the copies.

BUILDERS TIP

Find an empty window cleaner bottle and sprayer. Fill the bottle with water and add 4 or 5 drops of liquid dish washing detergent. Shake thoroughly. Spray this solution onto the back of your decals or trim sheets, or onto the surface where they will be placed. This allows you to position the decals or trim sheets without them sticking where you don't want them. When you are satisfied with their positions, squeeze the water out from under the trim sheet or decal with an epoxy spreader or a balsa paddle, and allow it to dry for at least 12 hours.

Paint the tail cone. All the prototypes were painted using Sig Supercoat Butyrate dope, which is already fuel proof. Before you install the canopy, carefully trim away the covering so the canopy parts can be glued directly to the wood surface. A neat method of attaching the canopy is to use RC-56 white glue. It dries slowly, and is crystal clear when dry. It never gets brittle, but remains slightly pliable throughout its life. Use 1/8" strips of masking tape to hold the parts while the glue dries.

FINAL ASSEMBLY.

□ 132. Re-Install all of your radio gear. Using epoxy, attach the wing fins to the wing tips. Use a tooth-pick to make small holes in the exposed foam at the end of the wing, and in the area where the covering was removed from the inside surfaces of the wing fins. Be sure the outer edges of the 1/2" wide outer cap strips are exposed to the epoxy too. This will give the epoxy a better "Grip" on the parts. The wing fins should be at a 90° angle to the top wing surface when this step is completed.

□ 133. Slide the canard into position under the steering link, using Sig C/A Plus (medium), or 5 minute epoxy to attach it to the fuselage, top and bottom. Be sure it is straight as determined by using the diagram to achieve equal distances on both sides.

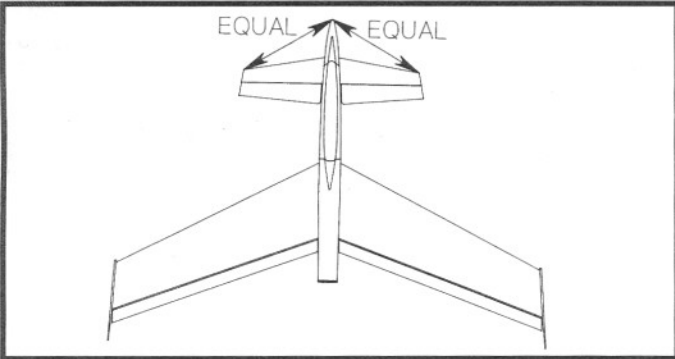

□ 134. Thread the Receiver antenna into the area at the front of the main wing through the hole in the bottom of bulkhead F-4. Next, with the fuselage upside-down, and holding the wing partially in the wing cavity, thread your receiver antenna into the tube in the left hand wing leading edge. As you get almost all of the antenna in place, drop the wing into final position, attaching it with the two #10-32 nylon screws provided. Gently pull the antenna tight at the outer end of the tube which exits the left hand wing fin.

□ 135. Install a couple of rubber bands, as shown on the fuselage side view, to hold the canopy/hatch in position.

INSTALLING EASY HINGES.

Sig's famous EASY HINGES have been included in your kit to hinge all the control surfaces. Each ultra-thin hinge is actually a three-part laminate, a tough plastic inner core sandwiches by an absorbent wicking material on each side. They are specially designed to be installed with thin CA glue. The hinges have been chemically treated to slow down the set time of the glue to allow it to soak all the way to the ends of the hinge and into the wood surrounding it, for a super strong bond. Once the glue has dried, the hinge cannot be pulled from the structure without tearing wood out with it! We recommend that all surfaces be completely covered before installing the EASY HINGES.

□ 136. Using the plan as a guide, locate, and re-cut the hinge slots you made in step 109. Insert the easy hinges halfway into the slots in the ailerons, and canard surfaces. **DO NOT GLUE THE HINGES YET!** Next, carefully slide the elevator assembly, and the ailerons, onto the hinges. Beginning at one end and installing the moveable surfaces at an angle works best.

□ 137. To set the correct hinge line gap, gently deflect the control surfaces about 30° in both directions. Keep the gap as small as possible but still allow for full surface deflection.

□ 138. Place two or three drops of **THIN, FOAM FRIENDLY, C/A** directly onto the hinge material exposed at the hinge gap. The glue will wick into the wood as it penetrates the hinge. Continue the process, gluing one side of all the hinges. Then turn the control surface over and repeat the process on the other side. **DO NOT USE ACCELERATOR.** Allow at least 15 minutes for the C/A to cure naturally.

□ 139. Using the Sig pushrod connectors provided, connect the aileron and elevator pushrods to the servo arms. Also connect the nose gear steering link to the aileron servo, as shown on Plan Sheet #2.

Hook up the clevises to the aileron horns and elevator horns.

Turn on your radio and double check to see if all the control movements are in the correct directions.

REMEMBER, PULLING THE TRANSMITTER ELEVATOR STICK TO THE UP POSITION SHOULD CAUSE THE CANARD ELEVATOR T.E. TO MOVE DOWNWARD.

RECOMMENDED CONTROL SURFACE MOVEMENTS.

The following surface movements are recommended for initial flight tests:

Elevators 3/8" Up & Down
Ailerons 3/8" Up & Down

For accomplished pilots and aerobatics, the following surface movements are recommended:

Elevators 3/4" Up & Down
Ailerons 5/8" Up & Down

BALANCING.

IMPORTANT: For optimum performance, your Tri-Star MUST be balanced between the two CG symbols shown on the main sheet of the full size plan. We do however, recommend that you balance the Tri-Star on the front CG location for your first flights. When you are more familiar with the model, and how it reacts to control inputs, you can begin to shift the balance point aft, toward the rearward CG point.

Make a balancer from a block of wood, and two eraser tipped pencils. Drill two holes for the pencils, in the wood block, that are about 3" apart. Install the pencils in the block as shown in the diagram.

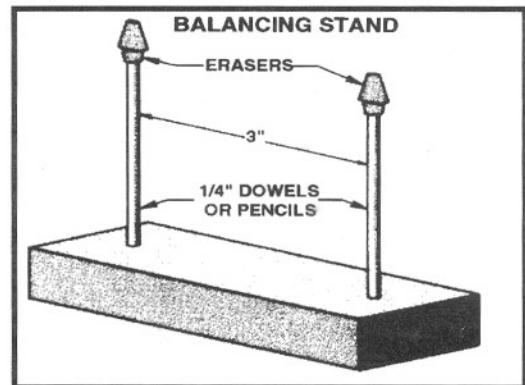

Mark the balance points on the bottom of each wing, close to the fuselage sides, using small pieces of 1/16" wide striping tape or 1/16"

strips of masking tape. These strips of tape should be placed 3", and 3- 3/4" respectively, behind the intersection of the wing leading edge and the fuselage side.

NOTE: For the glow powered version, the fuel tank MUST BE FULL when you balance the model. For the electric version, the electric motor battery MUST BE INSTALLED IN THE BELLY PAN when you balance the model.

Place the model on the balancer, with the erasers in line with the front pieces of tape. Adjust the receiver battery pack position, or the electric propulsion battery position to achieve the correct balance point. Very few of the prototype models required the addition of any weight to get them to balance, but this could be the case, depending on your chosen power plant, covering materials, etc.:

Trying to fly the model out of balance is much more dangerous than any small amount of weight that may need to be added to achieve proper balance. A slightly nose heavy model will generally fly, where a tail heavy model will usually be impossible to control.

□ 140. Using the balancer described in the paragraph above, carefully balance the plane where shown on the plan. It should sit level as shown.

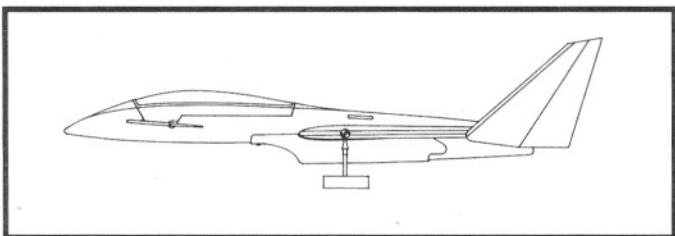

REMEMBER,
ON THE GLOW VERSION, THE FUEL TANK MUST BE FULL
WHEN YOU CHECK THE CENTER OF GRAVITY.

Otherwise your plane will get very tail heavy as you fill the tank, and will probably crash.

ON THE ELECTRIC VERSION, THE MAIN MOTOR BATTERY MUST
BE IN PLACE WHEN YOU CHECK THE CENTER OF GRAVITY.

The main power battery in the electric can be attached using small patches of velcro. This allows some position shifting for fine tuning the C.G.

□ 141. If you are building the Slope Soaring version of Tri- Star, Cut the 1/16" x 1/2" x 12" piece of ABS plastic into three equal parts. Round one end as shown in the upper left hand corner of the plan sheet. Install it as landing skids, using the remaining 1/16" x 1/2" double sided tape. A diagram showing the suggested positions for the landing skids is also shown in the upper left hand corner of the plan sheet.

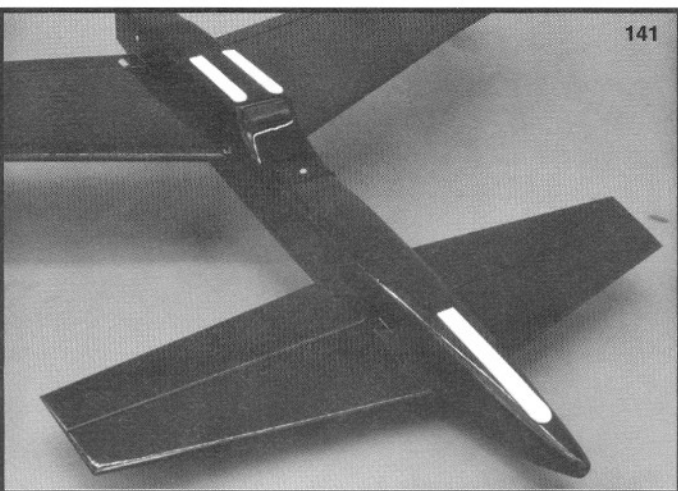

PRE- FLIGHT CHECK.

Make sure that all of your servos are securely mounted, and that all have their servo arm retaining screws in place. Double check all of the pushrod connectors, clevises, fuel tank lines, wheel collars, prop nut, and spinner if used. Range check your radio per the manufacturers recommendation. Make sure your transmitter and receiver batteries are fully charged.

DOUBLE CHECK EVERYTHING YOU CAN THINK OF! A Model and radio that are not prepared and working properly on the ground before take- off will not improve once in the air. **IT WILL ONLY GET WORSE.** Do NOT attempt to fly until everything is 100% functional.

FLYING THE TRI- STAR.

Flying the Tri- Star is no different than flying any other aileron/elevator airplane.

Fly fairly high on your first flights. It has been our experience as we allowed some others to fly our prototypes, that some disorientation occurred. This is due to the very different look of the canard in flight. After a little time in the air, you will come to appreciate this "Difference" and actually enjoy it.

A word of caution about electric powered airplanes. Some tend to under- estimate the power that a modern electric drive system can generate. Be Very cautious around electrics. The props are extremely sharp, and can be every bit as dangerous as those on a glow motor. Maybe even more so because they are so quiet.

Enjoy your Tri- Star. It is truly unique in the world of modeling.