

CLANCY
AVIATION

STAGGER **B**

COPYRIGHT © 2000
BY CLANCY AVIATION
ALL RIGHTS RESERVED

by Andy Clancy

CLANCY AVIATION
P.O. BOX 4125
MESA, AZ 85211-4125
TEL: (480) 649-1534
FAX: (480) 649-9040
www.clancyaviation.com

Building The Stagger Bee

My Guarantee

I guarantee the workmanship of my kits. If we make a mistake on your kit, I back it up! Let us know what the problem is so that we can fix it for you. If you have technical problems with my design - my advice only costs a phone call. Keep in mind that I am very busy, so please don't make me tell you what page you need to read in this book. Also: this is my personal phone number, and I have a family, so please confine your calls to weekdays between 9 to 5, AZ time. Calls placed after hours are answered whenever we can.

Many people who have had technical problems in the past with my designs did not follow the instructions; please remember this as you are building!!

Most balsa flying model planes are built directly over a full size drawing (or plan) of the plane. The plans are used as a jig to accurately position parts in relationship to each other. This method is the best way to build model planes, but it has one major drawback: the printing process can cause distortion of the plans-- and the paper itself also expands and contracts, causing inaccuracy of the plans. If the parts don't match the plans exactly, assume the parts are accurate. Adjust the assembly to match the *parts* (instead of reshaping the parts to match the plans).

A plane is divided into sub-assemblies that are built separately and joined together only after they have been covered. If your work space is limited, you may cut or fold the plans down to just the size of the sub-assembly you're working on.

Introduction & Useful Tips

Before removing the die cut parts from the boards, use a soft pencil to lightly mark the all the part numbers on the individual parts. The die cut parts fall into two groups: the Wing Parts (shown on the wing plans), and the Other Parts (shown on page 2 of the plans).

All the parts are shown full size on the plans. The wing part numbers indicate the assembly step that the part is first used in from the wing plans. The Other Parts have 2 numbers. The first number indicates the step in this instruction book where the part is first used. The second number indicates where the part goes in that step of the assembly. Some parts will also have a letter: "G" is for the glow version, and "E" is for the electric version.

You should plan on spending a little time using a single edge razor blade to cleanly cut the parts from the sheets, especially the plywood. At this time keep in mind that we die cut almost every last part! The first digit of each part identifies the assembly step it is used in. Arrange the parts in groups for each step.

Study the plans and instruction manual, step-by-step, from beginning to end. Build the plane once or twice in your head. Be sure to decide on the power plant and other options before you glue the first piece!

Glue Tips

Unless I specify otherwise, when I say to "glue" something, I am referring to the Cyanoacrylate or "CA" type of "super glue". I generally use the thin type CA, because it bonds better in most applications. If the odor of the CA bothers you, there are odorless CA glues available, although they are more expensive.

I also always use the long thin extender glue tips on my CA bottles, it helps me control the flow of the CA and I can put the glue precisely where it needs to go. Too much glue can weaken a bond just like too little glue can. If you are in a hurry to get your glue bonds set, there are also products available called "kickers" or "accelerators" that will instantly set the CA bond.

You will notice that I often mention things like "make sure the part is vertical" or "be sure the part is straight" in these instructions. This is because glue joints are stronger when the parts are perpendicular to each other. This is why a 90 degree angle is also called a "right angle" - because it is the *right* angle to use.

Ground Rules & Conventions

- 1) If the plans and the instruction book disagree, follow the plans.
- 2) When I refer to "glow" engines in these instructions, I am also including diesel and even ignition engines. It is just simpler to say "glow", instead of listing all the alternate engine types.

BUILDING THE FUSELAGE

STEP ONE - SIDES

I suggest a dry run on this step using only pins.

Assemble both fuselage sides as shown. Use the plans as a guide to locate the exact position of each part. Don't forget to build a left side and a right side. Line up the notches carefully.

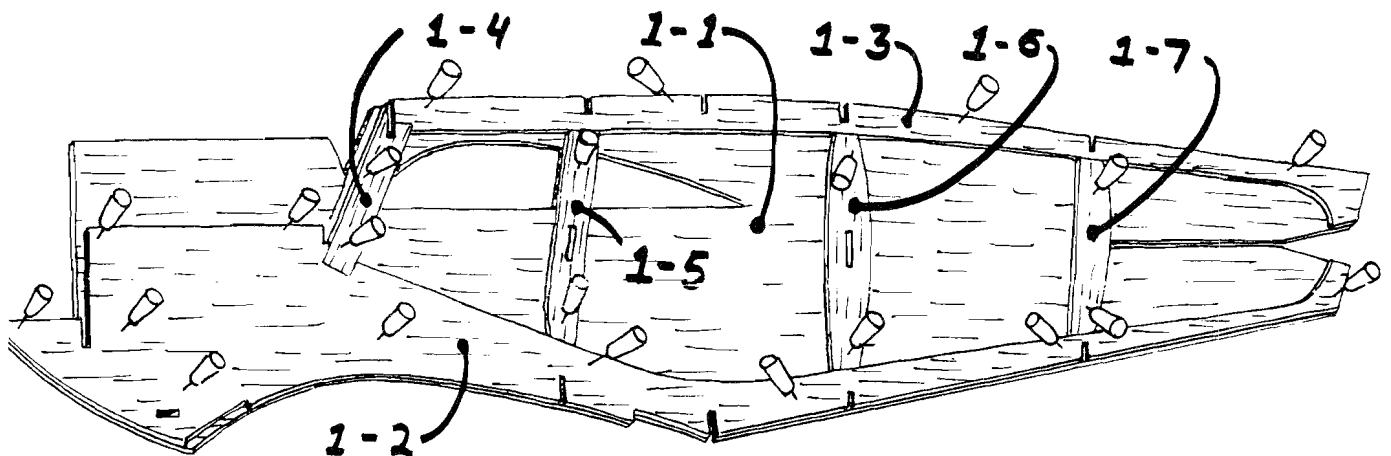

STEP TWO - FIREWALL

Laminate the correct firewall for the version you are building (either glow or electric). The electric firewall has a hole in it; the glow firewall does not.

Glue the firewall and cross members to the fuselage side as shown. Make sure they are perfectly vertical.

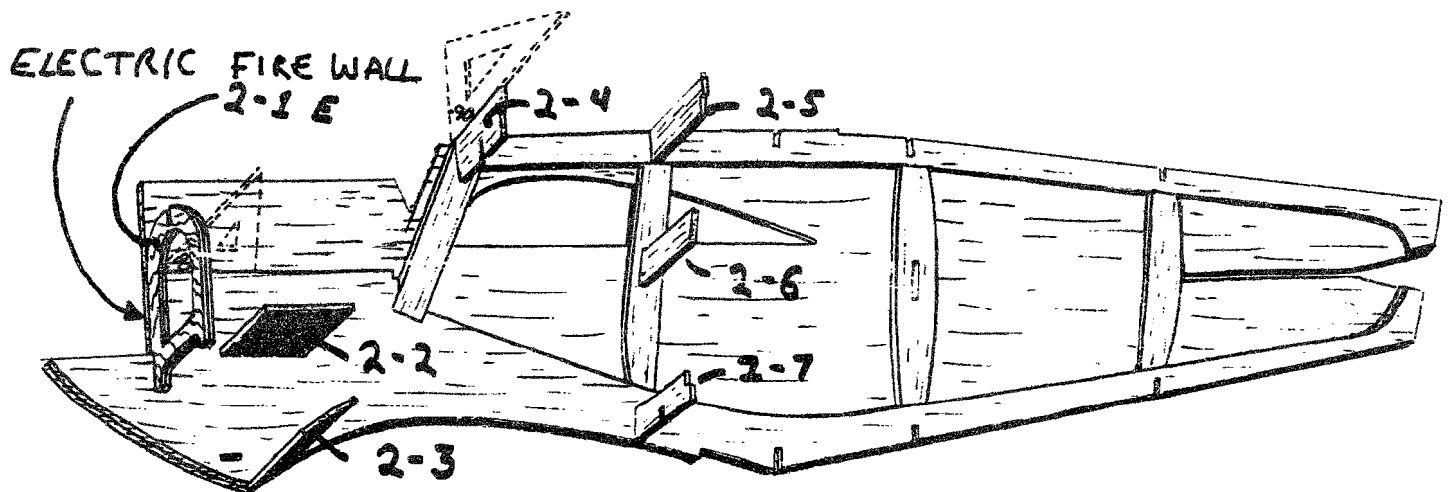
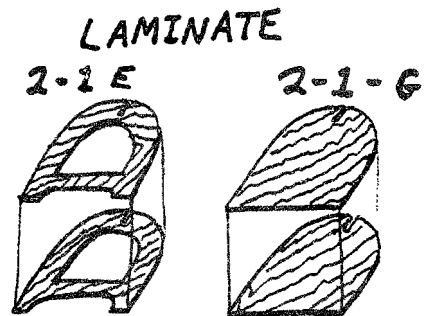
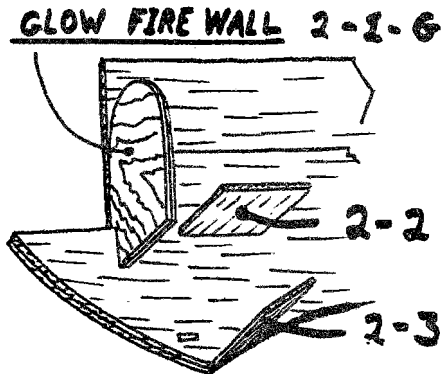

STEP THREE - PLYWOOD

Laminate the plywood parts as shown. Assemble the instrument board. Join the fuselage sides and parts with pins and clamps - Do NOT glue anything yet.

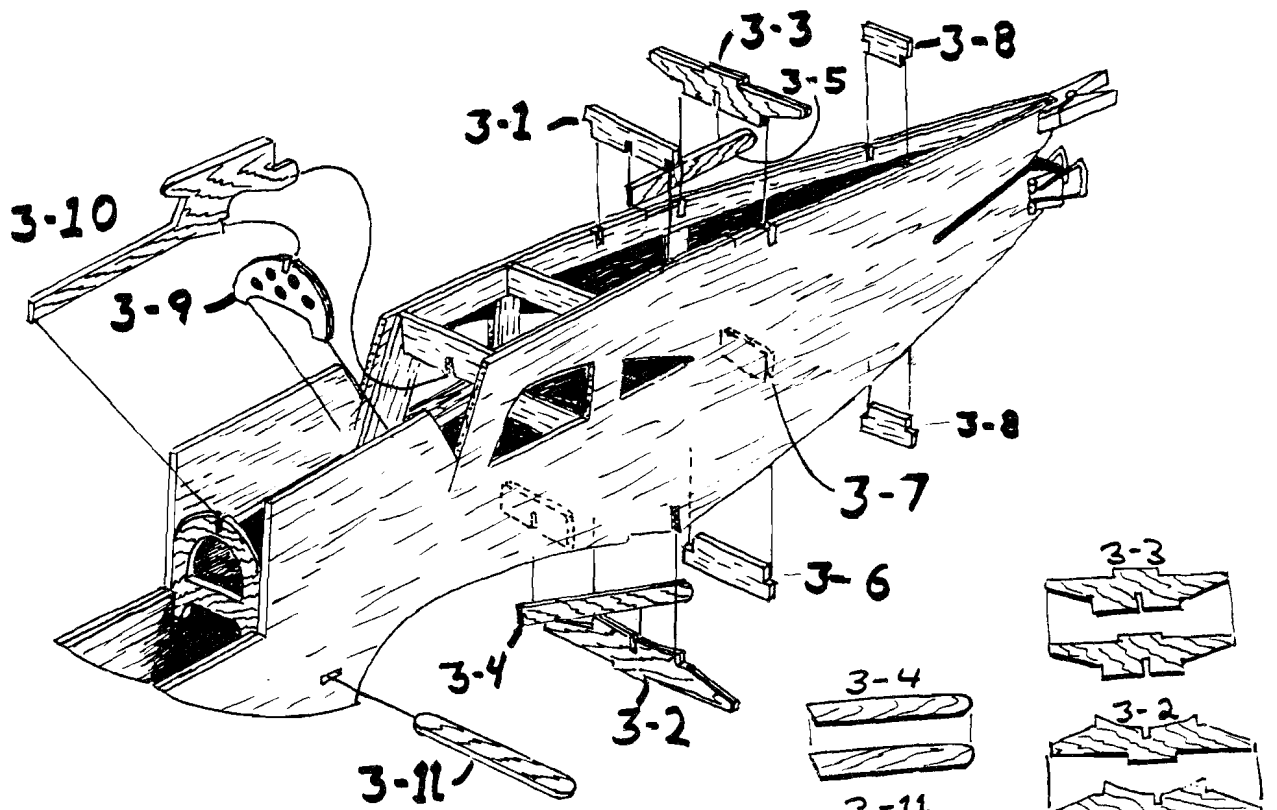

INSTRUMENT PANEL

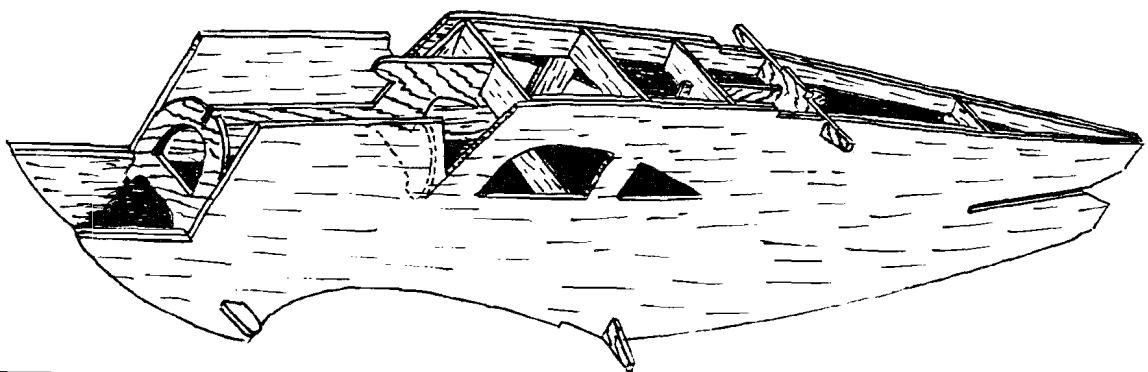
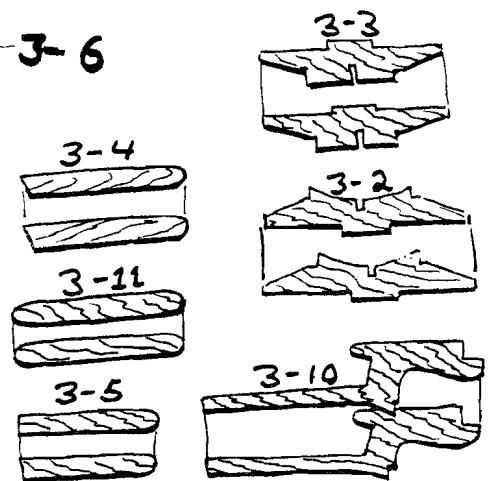
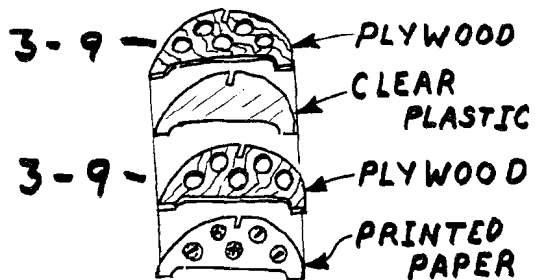

STEP FOUR - FUSELAGE

Pin the fuselage upside down on the top view of the plans over your building board. Make sure the fuselage is straight and that the sides are vertical *before* gluing. Then install the bottom sheeting as shown. Some minor trimming and beveling is required. Part # 3-11 is NOT glued until after covering.

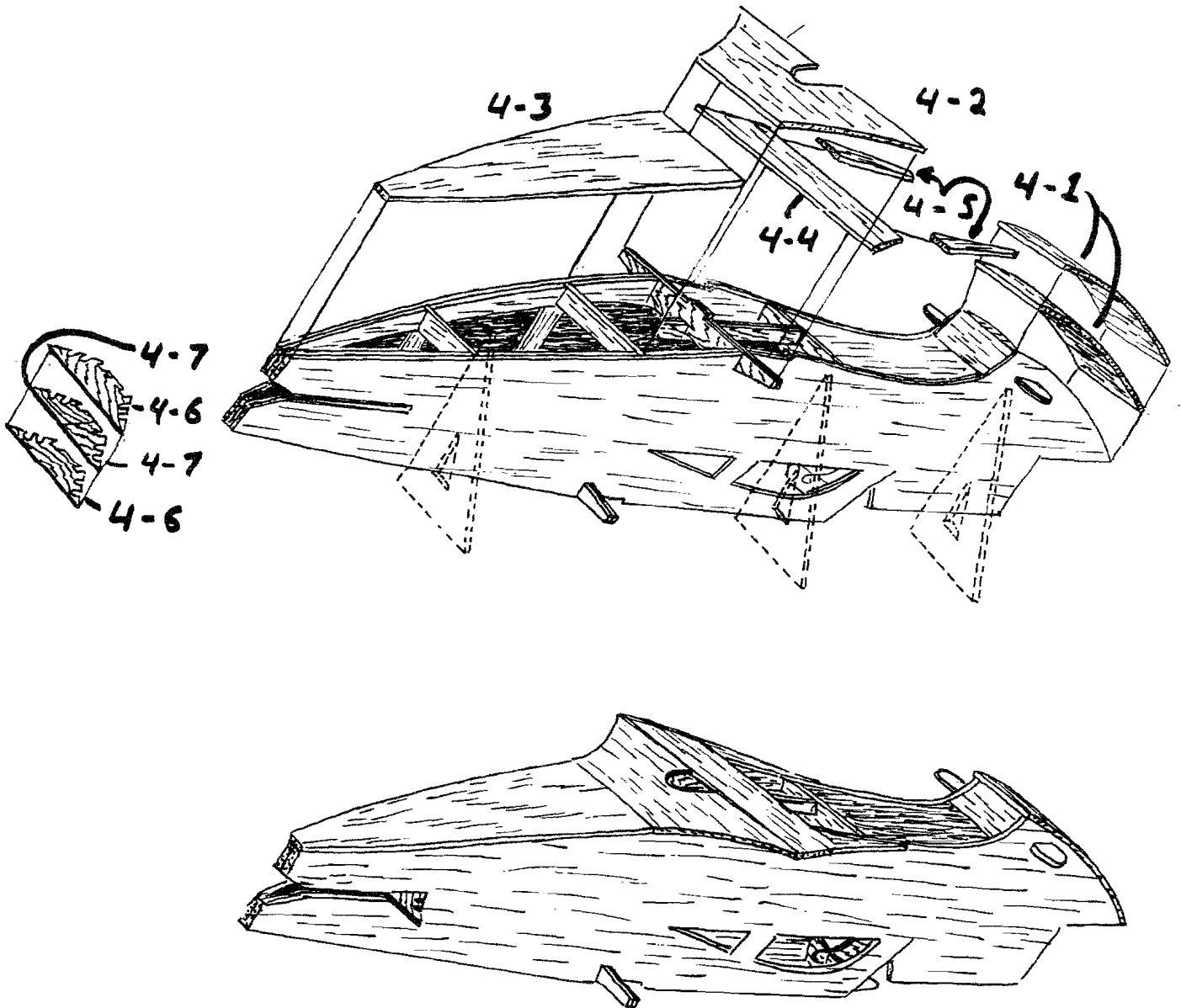

STEP FIVE

Assemble as shown in sketch. Note: The die cut plywood windshield parts are inaccurate, so we have included Laser cut parts instead. We also goofed on part # 5-1, so it will need to be trimmed. The template page shows the correction to this part. Some trimming and beveling is also required on the wing fillets.

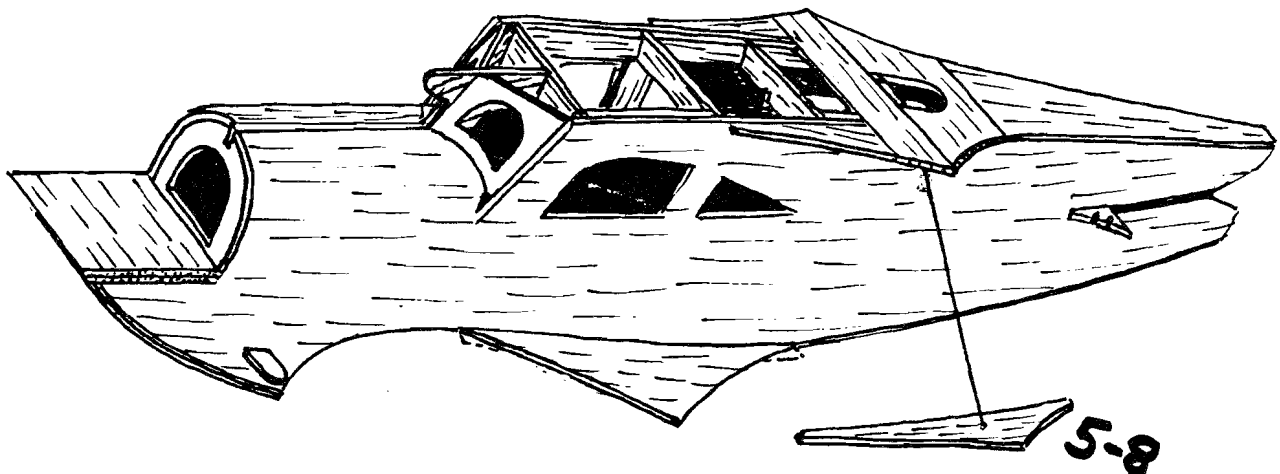
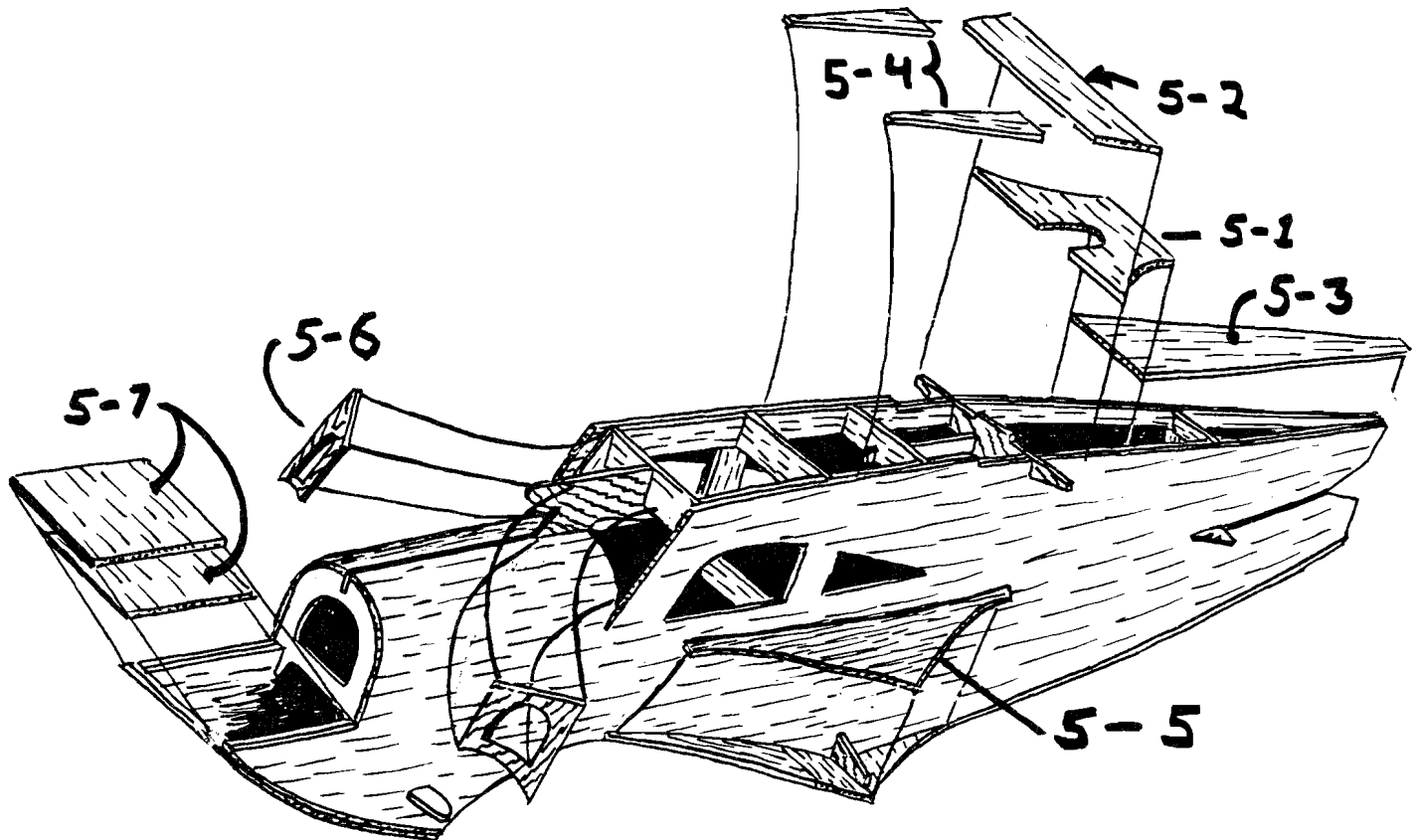

STEP SIX - ELECTRIC OPTION

The rubber band mounting works well for a large variety of electric motors. For larger motors the hole in the firewall can be enlarged and/or the mount could be lowered. The battery pack should be mounted on a shelf as shown in the sketch. Materials are not provided.

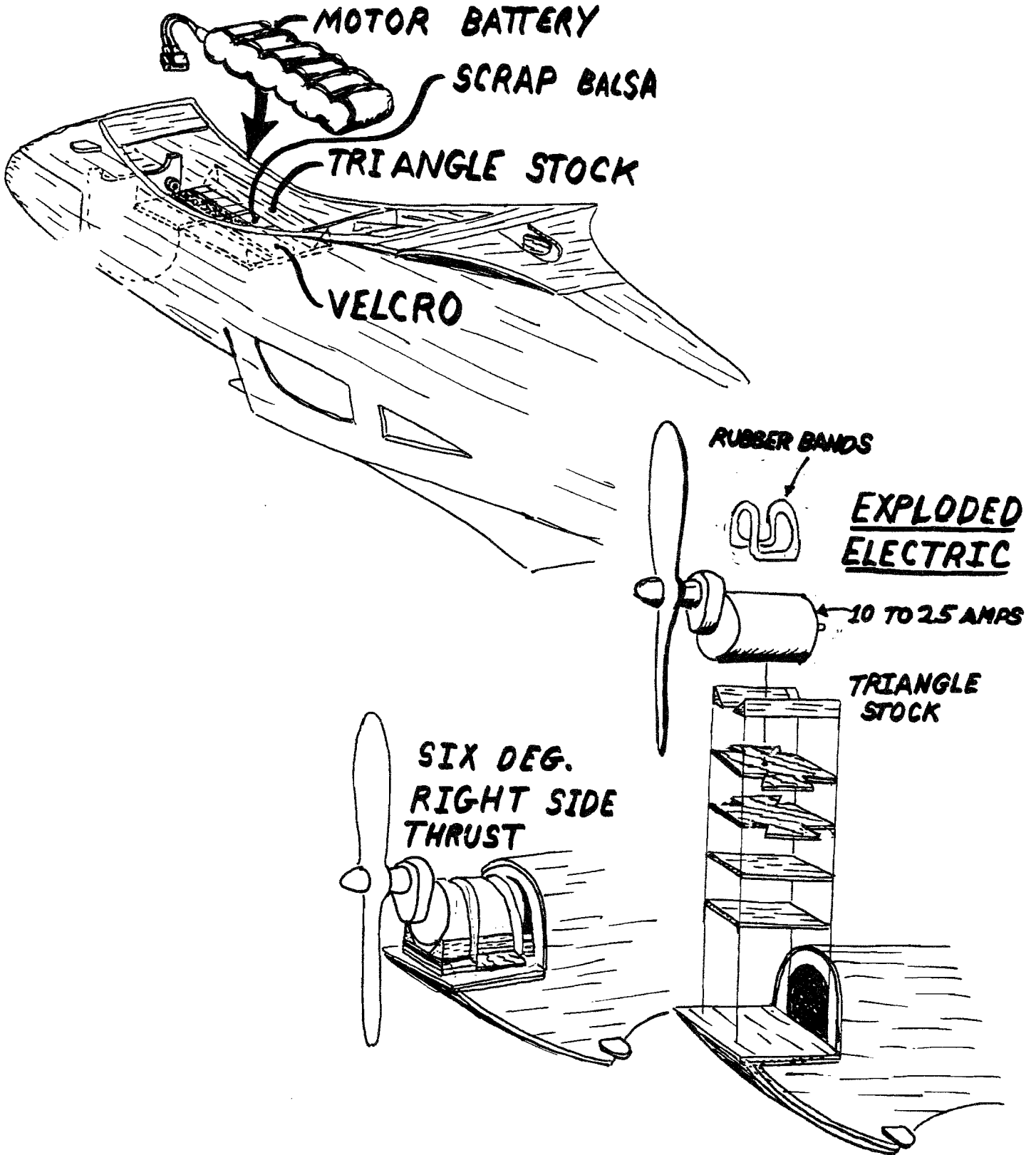

STEP SIX - GLOW OPTION

An extra 1/32" lamination is added to the front of the firewall. We have shown a typical glow engine installation. Six degrees of right side thrust is recommended. A 4 oz Sullivan Flex Tank will fit inside. When using larger engines, use large diameter, low pitch propellers.

GLOW FIREWALL

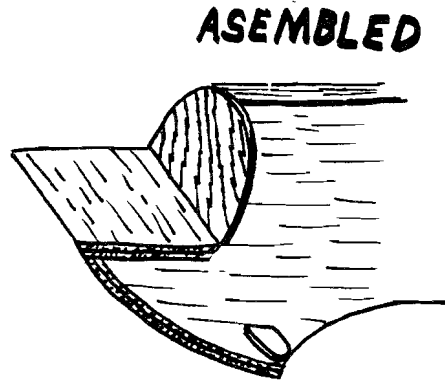
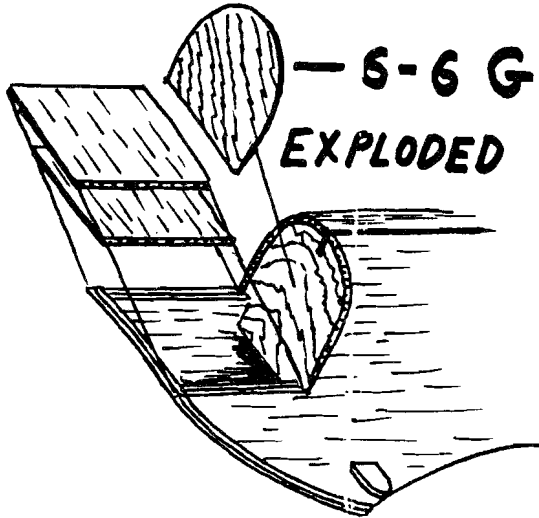

GLOW INSTALLATION
.061 2 CYCLE TO 30 FOUR

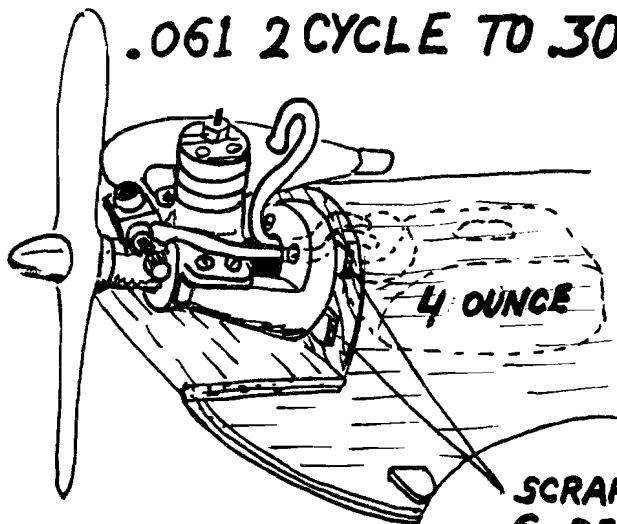

SCRAP PLY. SHIMS
6 DEG. RIGHT THRUST

STEP SEVEN - RUDDER

Build the rudder over the plans, beginning with the parts shown.

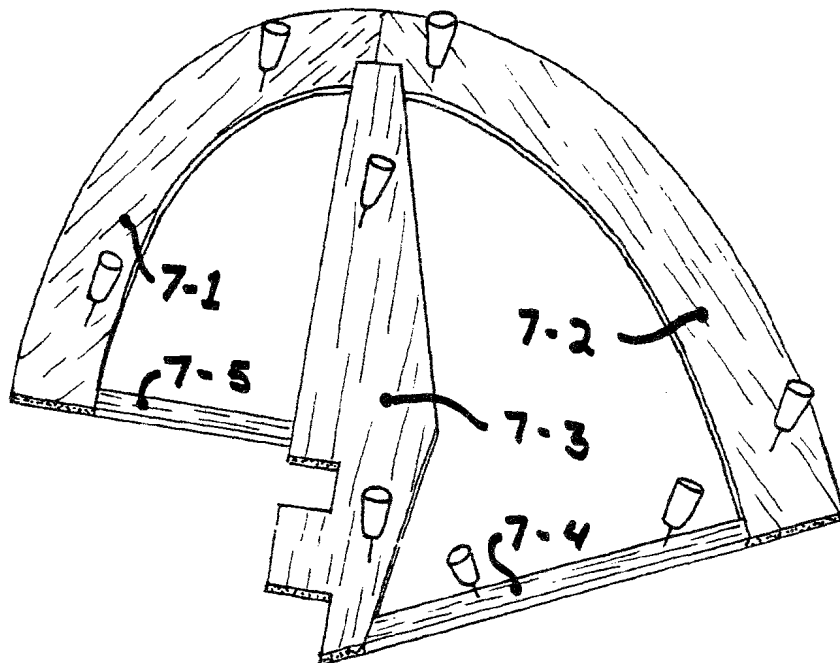

STEP EIGHT - RUDDER

Add the second layer of parts to the rudder and remove from the plans. Carefully modify the 1/4 scale hinges as shown. Use the plans to get the precise shape of the hinges.

MODIFY HINGE

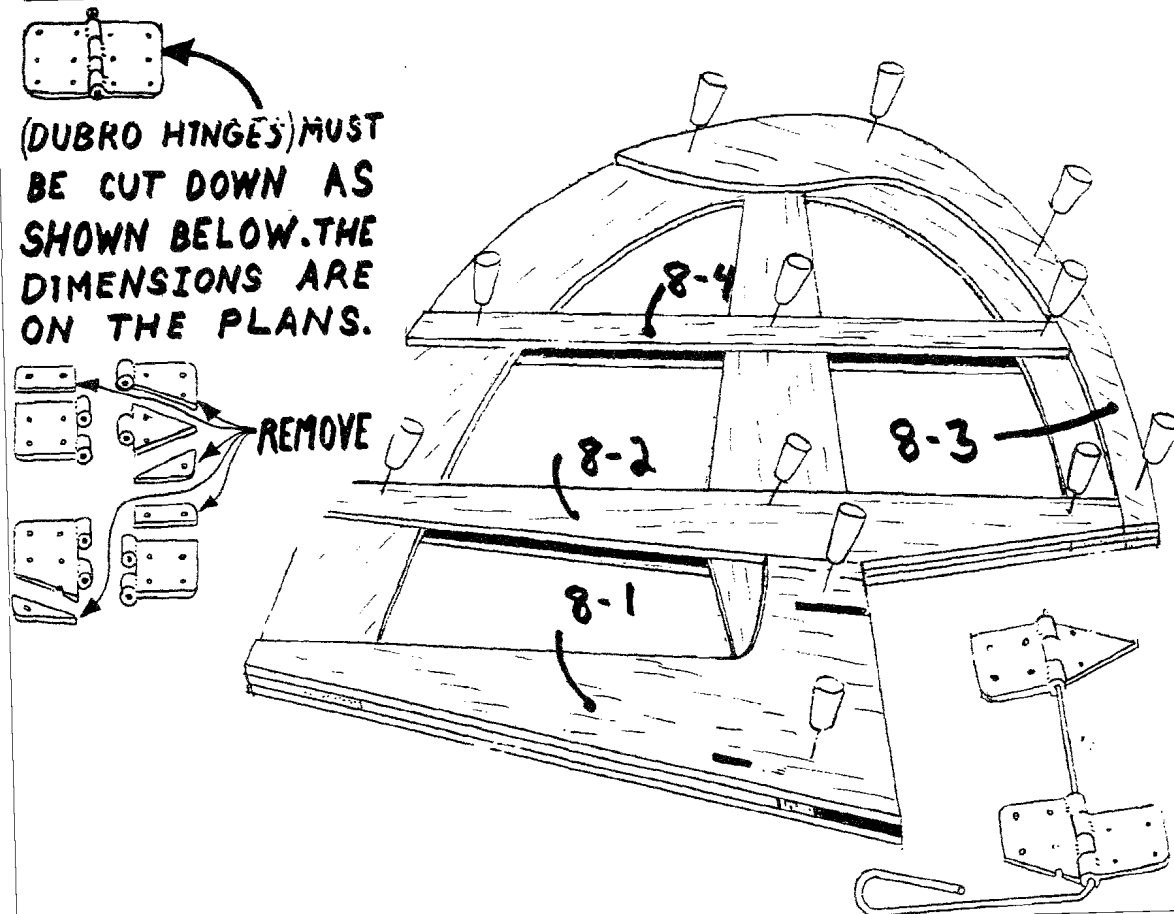

STEP NINE - RUDDER

Add the third layer of parts to the *other* side of the rudder.

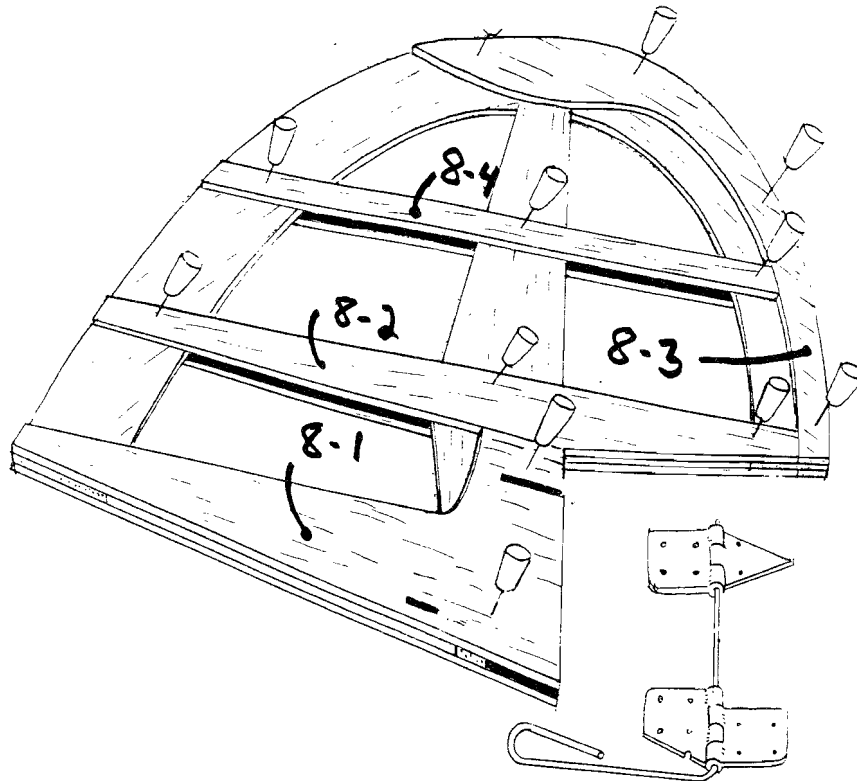

STEP TEN - RUDDER

The assembled and sanded rudder is shown below. The control horn is two layers of plywood. NOTE: The rudder sketches here show the rudder control horn on the opposite side from what the plans show. It doesn't matter which side it's on - so long as it's not on the same side as the elevator control horn.

The hinges and Part# 10-1 and Part # 10-2 should not be glued down until after covering the plane.

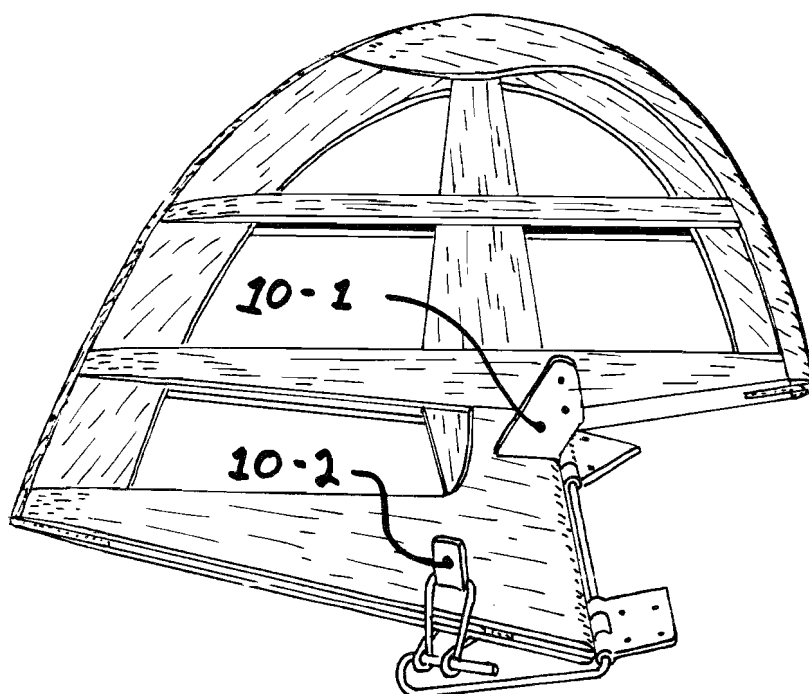

STEP ELEVEN - STABILIZER & ELEVATOR

This sketch shows the assembled stabilizer and elevator. Cutting the slots for the hinges is tricky - practice on some scrap wood first. Use a single edge razor blade. Make sure you mount the control horn on the opposite side from the rudder control horn. The hinges and horns should be mounted after the covering is completed.

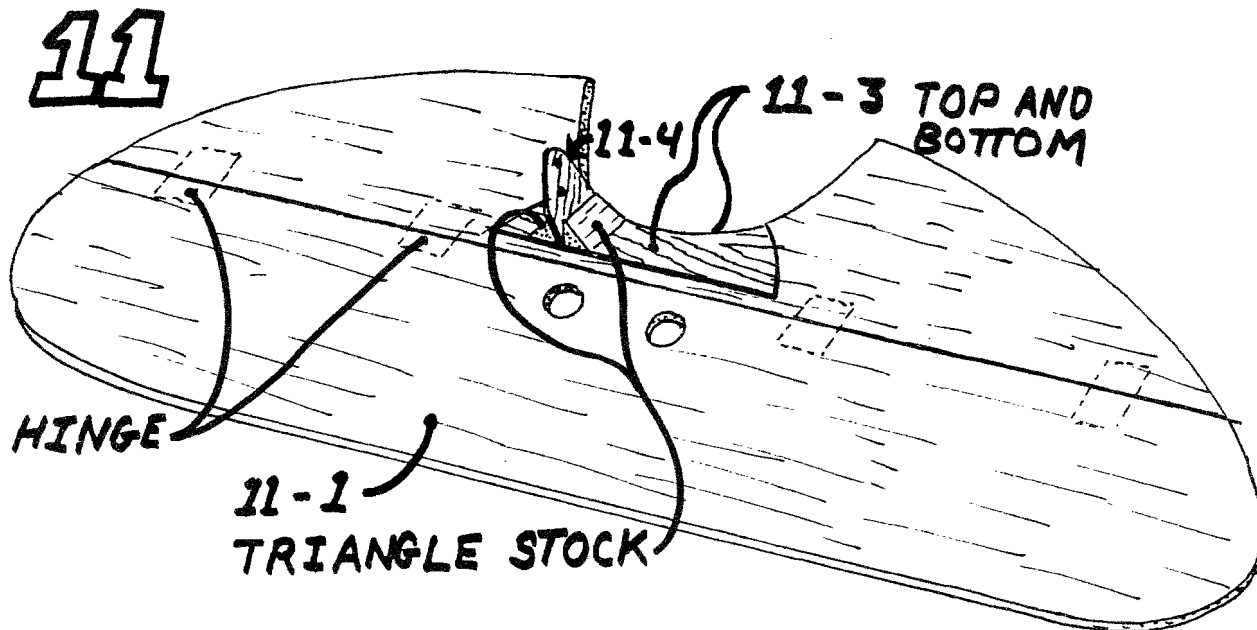

STEP TWELVE - WHEEL SKIRTS

The parts for one wheel's skirt are shown. Be sure to make a left side and a right side for each of the wheel skirts.

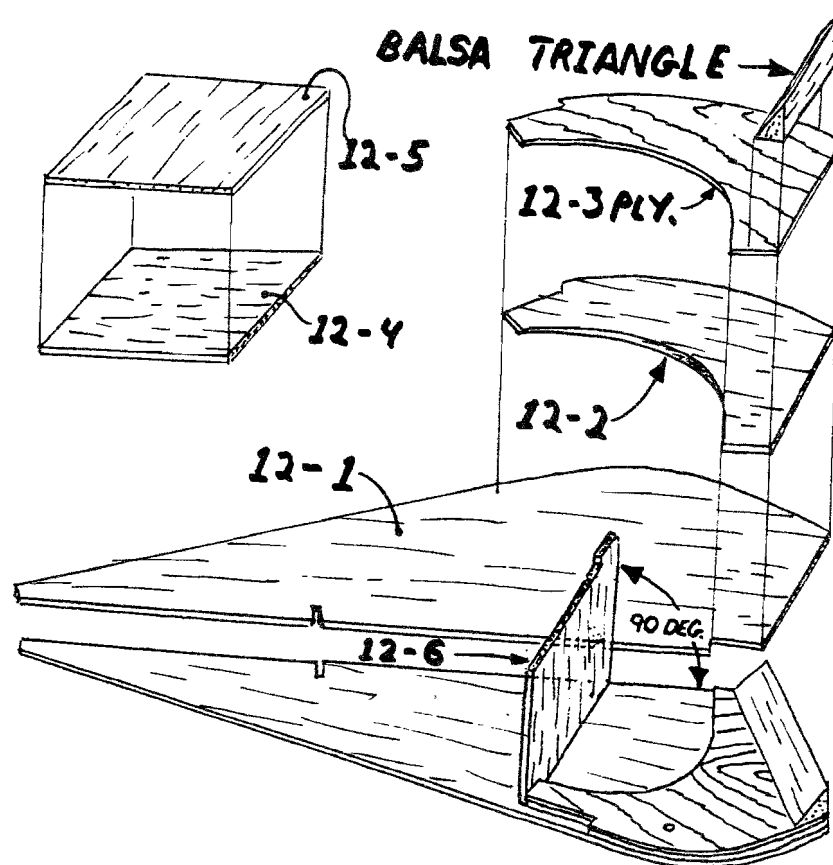

STEP THIRTEEN - WHEEL SKIRTS

Assemble the wheel skirts as shown. Note that the wheel hubs are offset to one side. This is to allow room for the wheel collar.

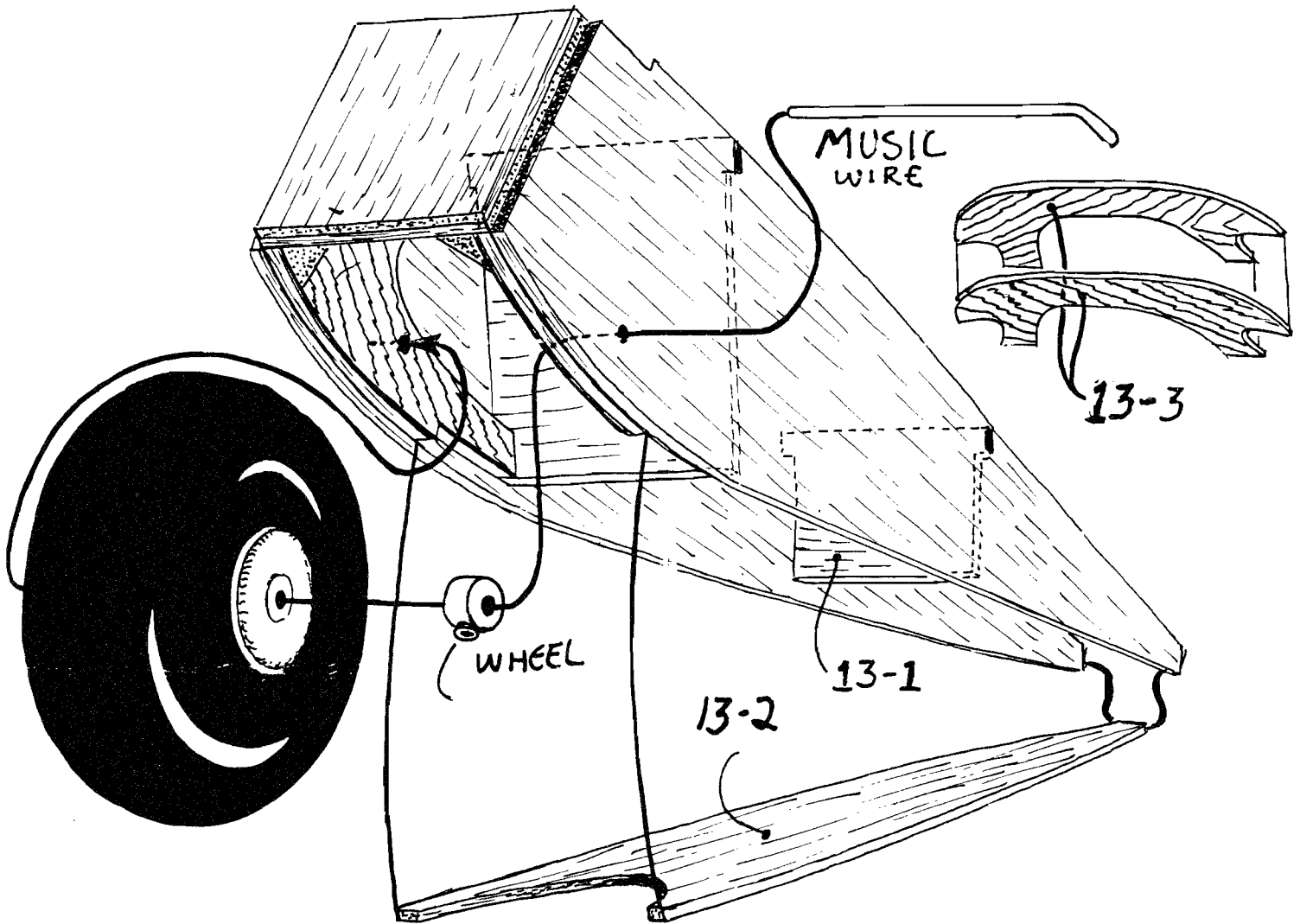

Carve and sand the wheel skirt as shown. I use 80 grit sandpaper for shaping the parts. The laminated part # 13-3 is not installed until after covering.

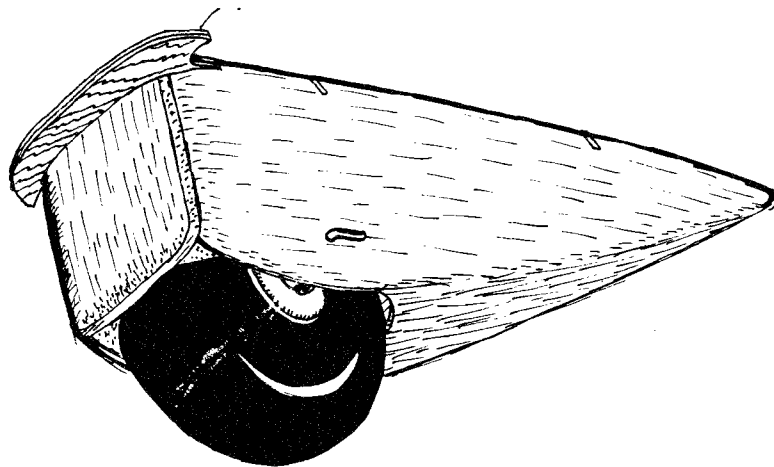

STEP FOURTEEN - WHEEL SKIRT INSTALLATION

To install the wheel skirts on the bottom wing:

- 1st - Build and cover the wing,
- 2nd - Install rubber band on wing
- 3rd - The forward rubber bands are attached to the skirt by sliding the skirt forward. Use a scrap sheet of balsa to lift the rubber bands over the flange on the skirt, and move the rear of the skirt from side to side.
- 4th - Once the front of the skirt is attached to the wing, lift up the rear of the skirt to grab the rear rubber band, and then pull it over the rear of the skirt.

Although it may seem complicated now, this task gets to be easy and routine after you learn how to do it and get some practice at it. It is certainly less frustrating than repairing damaged landing gear.

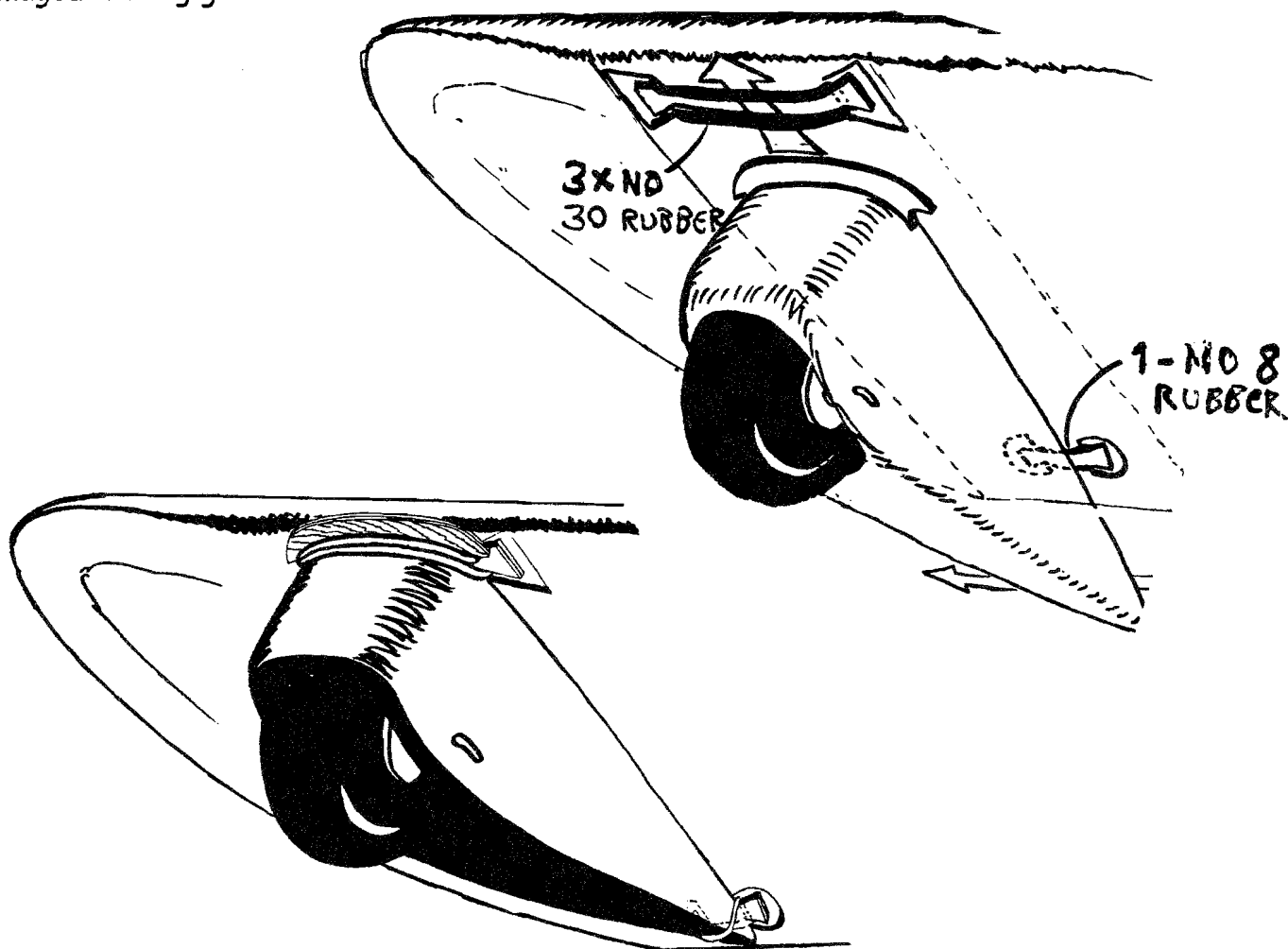

RADIO EQUIPMENT & INSTALLATION

Use the smallest and lightest radio gear that you can afford. However, any radio gear that will fit inside *may* work, provided that you don't do anything else to add weight to the plane and that you have a powerful motor.

I always mount my radio gear last to balance the plane. If you mount the radio gear before the plane is finished, mount it as far forward as possible. It is much better to balance a nose heavy plane by adding a tiny amount of ballast to the tail, than to balance a tail heavy plane with a large weight in the nose!

The servos can be mounted to the fuselage sides with 2-sided tape. Be sure to coat the balsa with CA to make the tape stick to it. Before mounting the servos, make and install the push rods. Attach the servos to the push rods and adjust the position of the servos to center the push rods. For docile handling, we recommend 3/4" throw each way for the elevator and a 1" throw each way for the rudder.

The Flirtatious Pilot Option

Buy or make a pilot's head with a likeness of yourself (or any other favorite face). The pilot's head is mounted on top of the rudder servo. So, with full left rudder, the pilot should look out the left side of the plane. With full right rudder, he should look forward. The hand is coupled to the elevator servo so that the pilot "waves" by moving the elevator. This set-up has been a big hit with almost everyone who has seen it. While I'm showing off my plane, I just tell people that it's me in the cockpit. When they look, the little pilot turns toward them and waves.

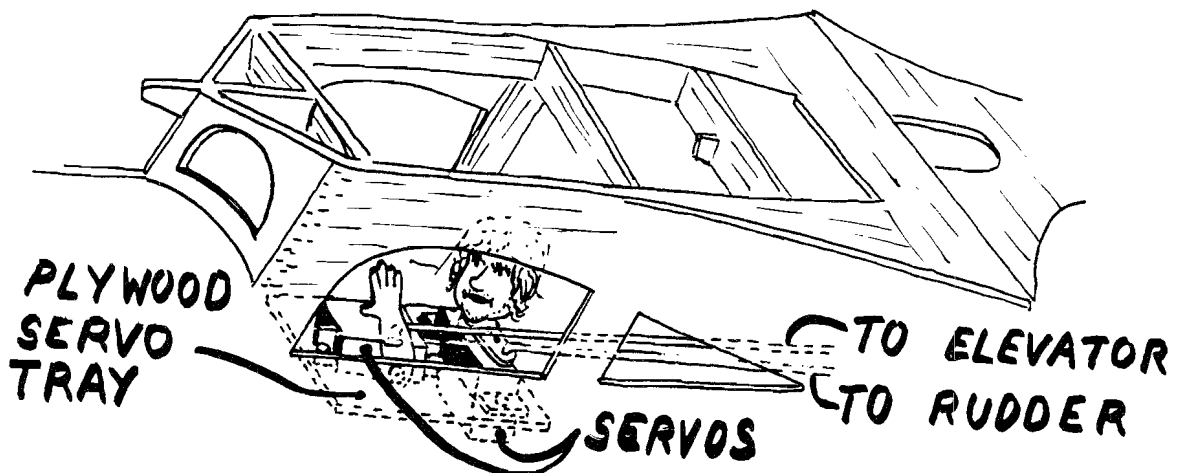

Covering and Finishing

We have included iron-on Mylar covering in the kit. It is self-adhesive: the dull side has the adhesive on it. There should be enough Mylar to cover both wings and the rudder. The fuselage, wheel skirts, and stabilizer can be left uncovered. Bare balsa is fine for electric powered models, or the wood can be fuelproofed and water proofed with dope or Black Baron Epoxy spray paint. This Mylar is also used for the windows. You can also use any other type of covering that you like. Keep in mind that covering can have a big impact on the plane's weight.

A small motor and heavy covering will produce a tail heaviness (It's not a problem for big motors though). My favorite lightweight coverings are Airspan, Litespan, and Fibafilm which we sell. Call me for a recommendation

**BALANCE 1 3/8 INCH OR 33mm
LEADING EDGE OF TOP WING
WITH NOSE SLIGHTLY DOWN.**

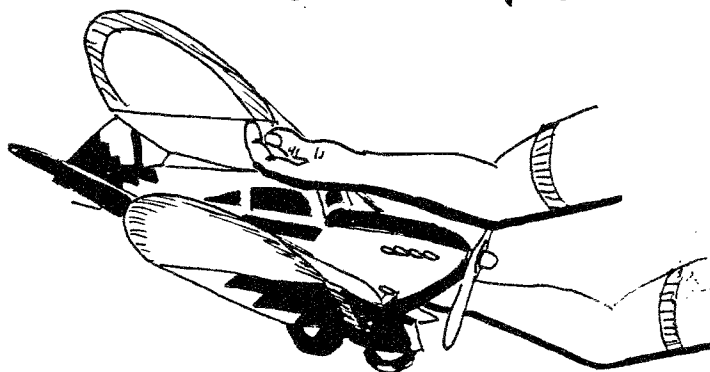

The Carved Cowl

To make a carved cowl, mount a block of wood to the firewall with screws as shown. Carve and sand it to shape while it is still attached to the firewall. Remove and hollow out the block so that it fits over your powerplant by trial and error.

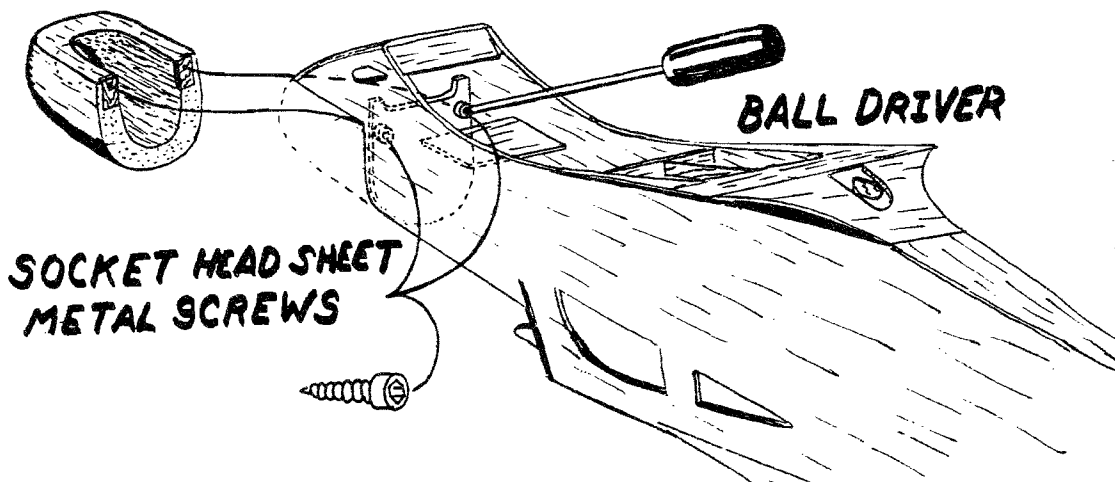

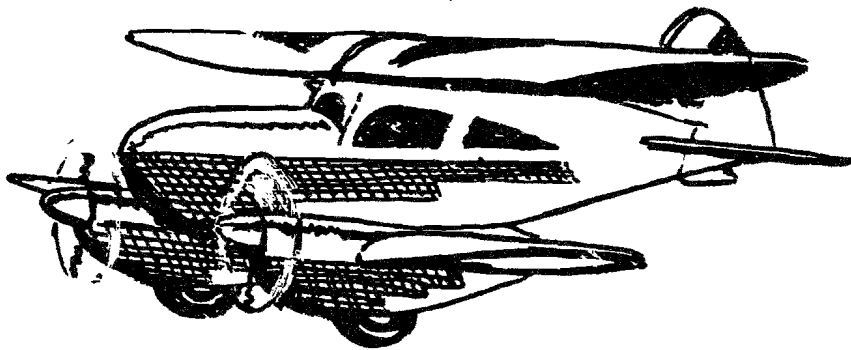

The inspiration for the *Stagger Bee* comes from the Stitt's *Sky Baby* and the Beech *Staggerwing*. Beechcraft engineers wanted to build a twin-Menasco powered version of the *Staggerwing*. The British De Havilland works mass produced the beautiful twin-engine biplane called the *Dragon Fly* with combined engine nacelles and wheel fairings. So, why not a twin-motored *Stagger Bee*? A tri-motor would be another way to go - like the famous De Havilland Comet or Junkers Ju-52. Multi-motor planes throw lots of prop wash over the wing and so will fly slower than a single motor plane of the same weight.

Let me know how it works!