

SPIRIT ELITE™



INSTRUCTION MANUAL



WARRANTY

Great Planes® Model Manufacturing Co. guarantees this kit to be free from defects in both material and workmanship at the date of purchase. This warranty does not cover any component parts damaged by use or modification. **In no case shall Great Planes' liability exceed the original cost of the purchased kit.** Further, Great Planes reserves the right to change or modify this warranty without notice.

In that Great Planes has no control over the final assembly or material used for final assembly, no liability shall be assumed nor accepted for any damage resulting from the use by the user of the final user-assembled product. By the act of using the user-assembled product, the user accepts all resulting liability.

If the buyer is not prepared to accept the liability associated with the use of this product, the buyer is advised to return this kit immediately in new and unused condition to the place of purchase.

READ THROUGH THIS MANUAL BEFORE STARTING CONSTRUCTION. IT CONTAINS IMPORTANT WARNINGS AND INSTRUCTIONS CONCERNING THE ASSEMBLY AND USE OF THIS MODEL.



P.O. Box 788 Urbana, IL 61803 (217) 398-8970
www.greatplanes.com

PROTECT YOUR MODEL, YOURSELF & OTHERS

WARNING! THIS IS NOT A TOY!

This R/C kit and the model you will build is not a toy! It is capable of serious bodily harm and property damage. **IT IS YOUR RESPONSIBILITY AND YOURS ALONE** - to build this kit correctly, to properly install all R/C components and to test and fly the model **only** with experienced, competent help in accordance with all safety standards and common sense as set down in the Academy of Model Aeronautics Safety Code. It is suggested that you join the AMA to become properly insured before you attempt to fly this model. IF YOU ARE JUST STARTING R/C MODELING, CONSULT YOUR LOCAL HOBBY SHOP OR WRITE TO THE ACADEMY OF MODEL AERONAUTICS TO FIND AN EXPERIENCED INSTRUCTOR IN YOUR AREA.

Academy of Model Aeronautics



5151 East Memorial Drive
Muncie, IN 47302-9252
Tele. (800) 435-9262
Fax (765) 741-0057

Or via the Internet at: <http://www.modelaircraft.org>

INTRODUCTION

Thank you for purchasing the Great Planes **SPIRIT ELITE** sailplane. Soaring offers a freedom that no other type of flying can provide! With a little practice and some help from mother nature, you will be able to defy gravity and enjoy flights that can last for hours.

The **SPIRIT ELITE'S** wing uses the SA7035 airfoil at the root blending to the SA7036 airfoil at the tip. This combination gives the aircraft a superior Lift to Drag (L/D) ratio with outstanding performance in higher wind conditions. This advanced wing design incorporates flaps and ailerons to provide the ultimate in control when using computer radio mixing functions.

Take your time and follow directions to end up with a well-built model that is straight and true.

Other Items Required

- Radio having at least 4 channels (5 channels required for crow mixing)
- Iron-on Covering Material (2 rolls)
- Latex Foam Rubber Padding (1/4" thick) (HCAQ1000)
- Hi-start or other Launching Device (DYFP8302)
- BB's or Lead Shot for Balancing

Supplies & Tools Needed

- 2 oz. Thin CA Adhesive (GPMR6003)
- 1 oz. Medium or Thick CA Adhesive (GPMR6008)
- 5-Minute Epoxy (GPMR6045)
- Hand or Electric Drill
- Sealing Iron (TOPR2100)
- Heat Gun (TOPR2000)
- Razor Saw
- Hobby Knife, #11 Blades
- Screw Drivers
- T-Pins (HCAR5100)
- Straightedge
- Sandpaper (coarse, medium, fine grit)*
- Easy-Touch™ Sander (GPMR6170)
- Plan Protector or Wax Paper (GPMR6167)
- Lightweight Balsa Filler (HCAR3401)
- 10-24 Tap, Tap Wrench

WING OPTIONS

The **SPIRIT ELITE** kit has two different wing options: a straight wing or a polyhedral wing. The straight wing is for the more experienced sailplane pilot. It allows better coordinated turn efficiency and much better handling in cross winds. The polyhedral wing has more stability, turns tighter with rudder, and is generally easier to fly. If you are a novice sailplane pilot we recommend you build the polyhedral option.

Types of Wood



BALSA

BASSWOOD

PLYWOOD

Get Ready to Build

1. Unroll the plan sheet. Reroll the plan inside out and let it uncurl. This will help the plan lie flat.
2. Remove all parts from the box. Identify each part by comparing it with the plan, parts list and die-cut parts page. Write the part **number** or **size** on each piece to avoid confusion later. Use the die-cut patterns shown on page 3 to identify and mark the die-cut parts.
3. If any of the die-cut parts are difficult to remove, use a hobby knife to free them. Use your sanding block to **lightly** sand the edges to remove any die-cutting irregularities.

DIE-CUT PATTERNS

SPELFO1 (2 per kit)

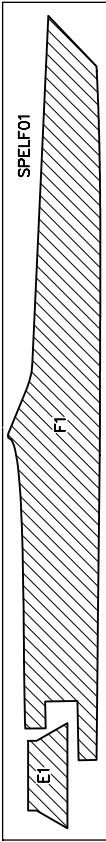

3/32" x 3" x 24" Balsa
(2.5mm x 76mm x 610mm)

SPELFO2 (2 per kit)

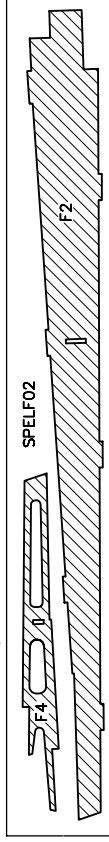

3/32" x 3" x 24" Balsa
(2.5mm x 76mm x 610mm)

SPELFO3 (1 per kit)

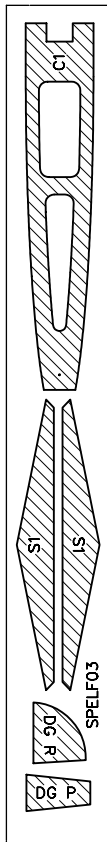

3/32" x 3" x 24" Balsa
(2.5mm x 76mm x 610mm)

SPELFO4 (2 per kit)

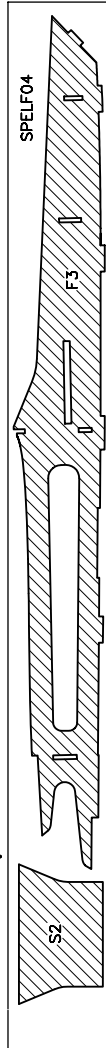

3/32" x 3" x 30" Balsa
(2.5mm x 76mm x 762mm)

SPELFO5 (1 per kit)

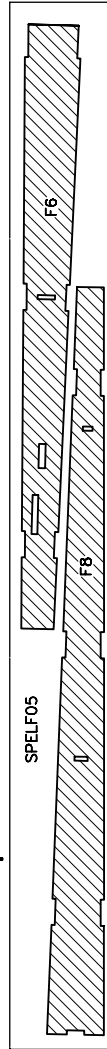

3/32" x 3" x 30" Balsa
(2.5mm x 76mm x 762mm)

SPELW01 (2 per kit)

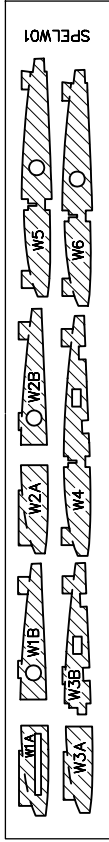

1/16" x 3" x 24" Balsa
(1.5mm x 76mm x 610mm)

SPELW02 (2 per kit)

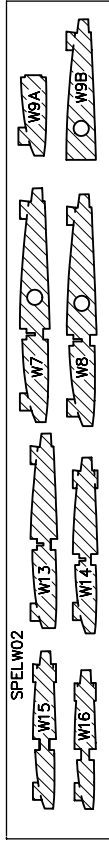

1/16" x 3" x 24" Balsa
(1.5mm x 76mm x 610mm)

SPELW03 (2 per kit)

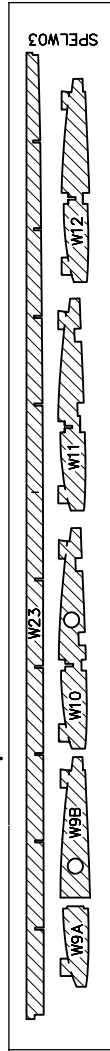

1/16" x 3" x 30" Balsa (1.5mm x 76mm x 762mm)

SPELFO6 (1 per kit)

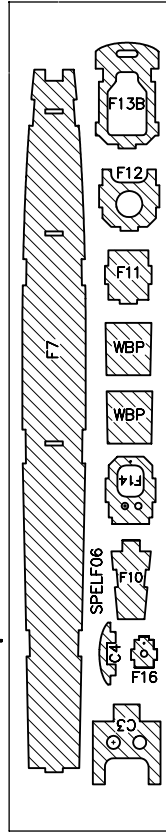

ASSEMBLE THE TAIL

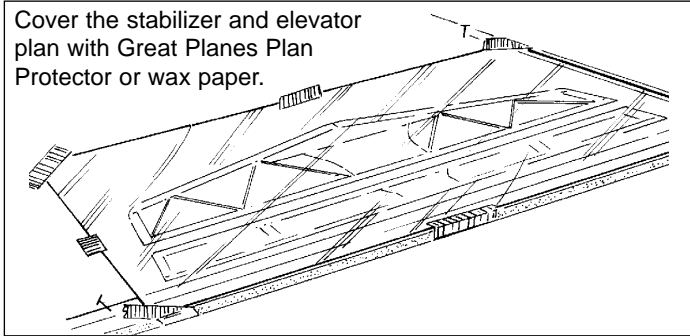

Step 1

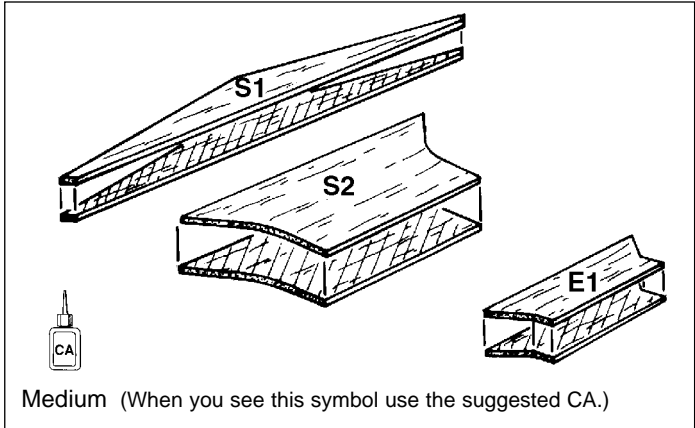

Step 2

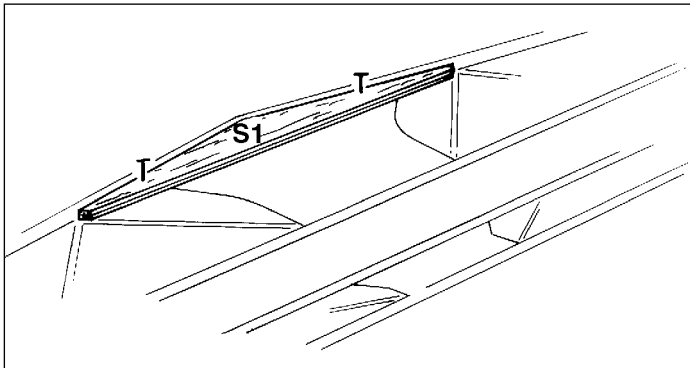

Step 3

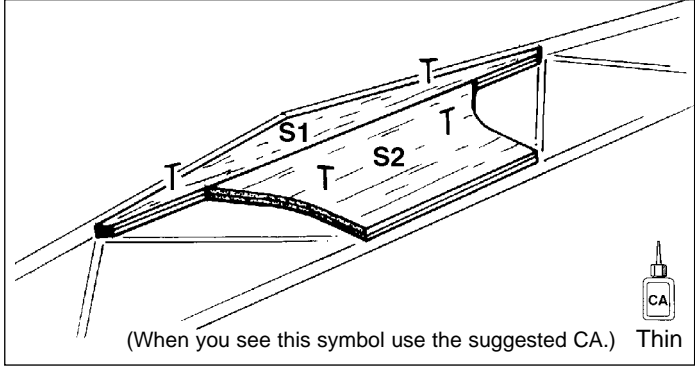

Step 4

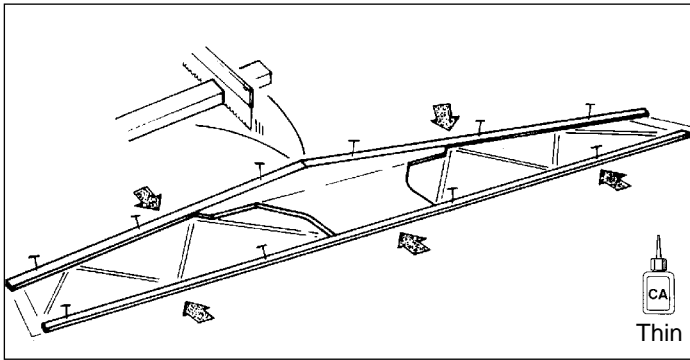

Step 5

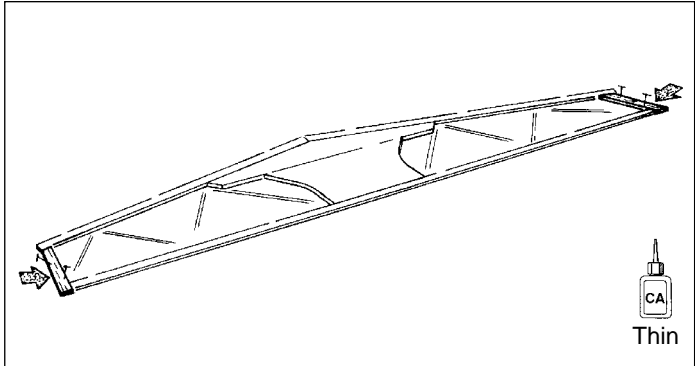

Step 6

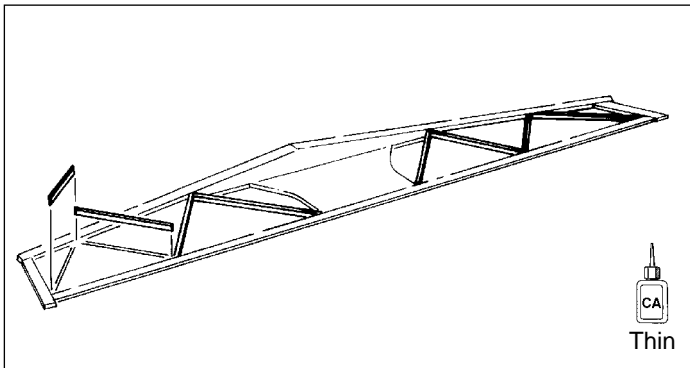

Step 7

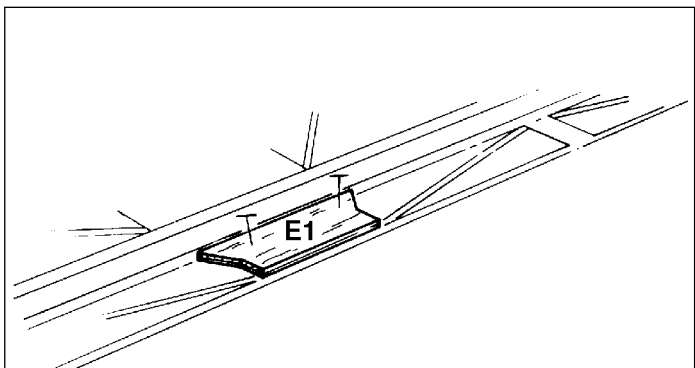

Step 8

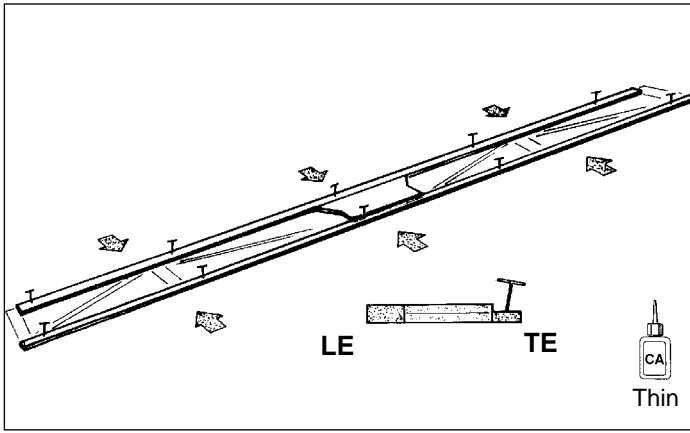

Step 9

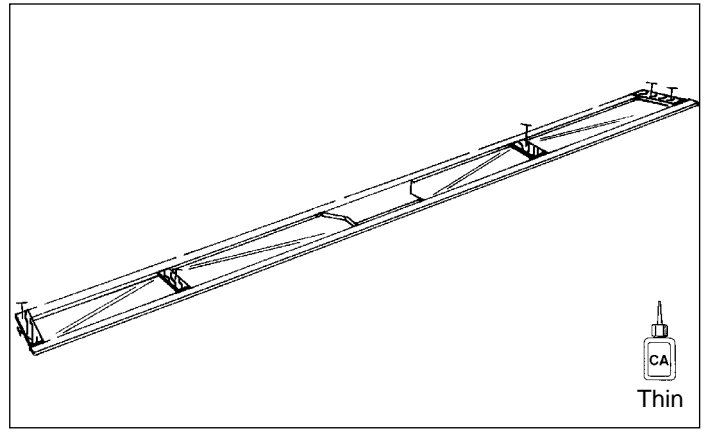

Step 10

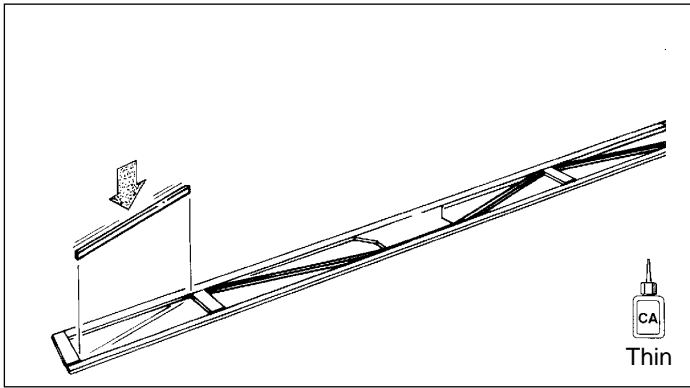

Step 11

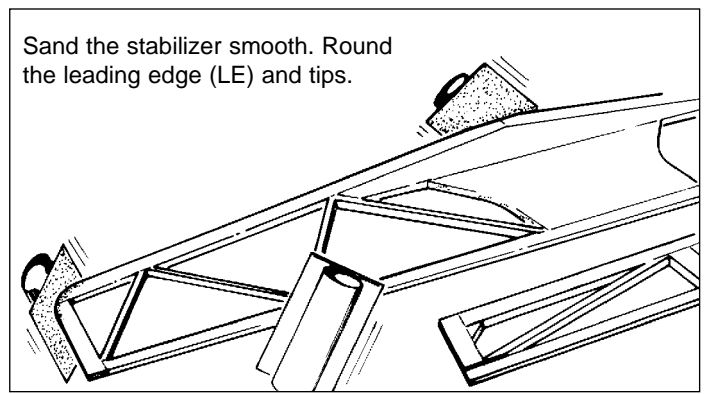

Step 12

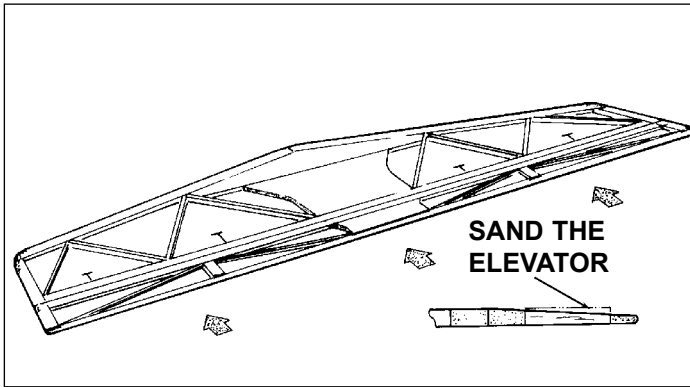

Step 13

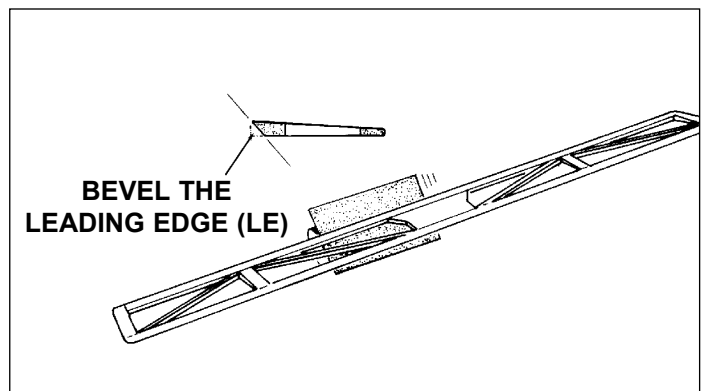

Step 14

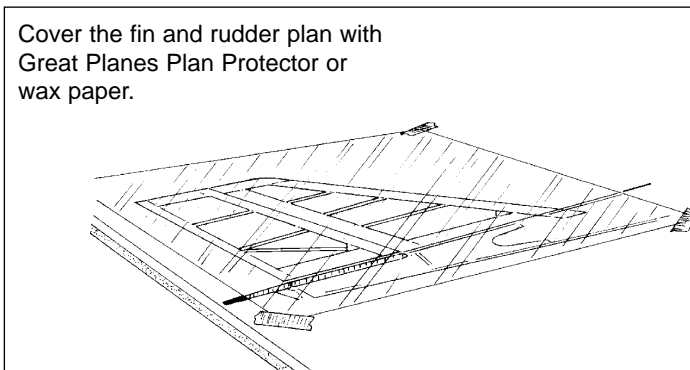

Step 15

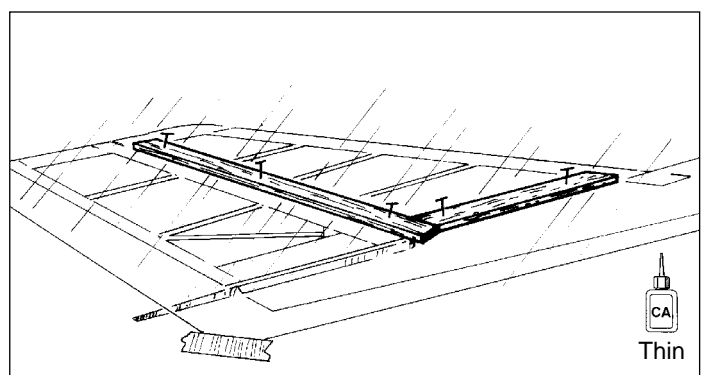

Step 16

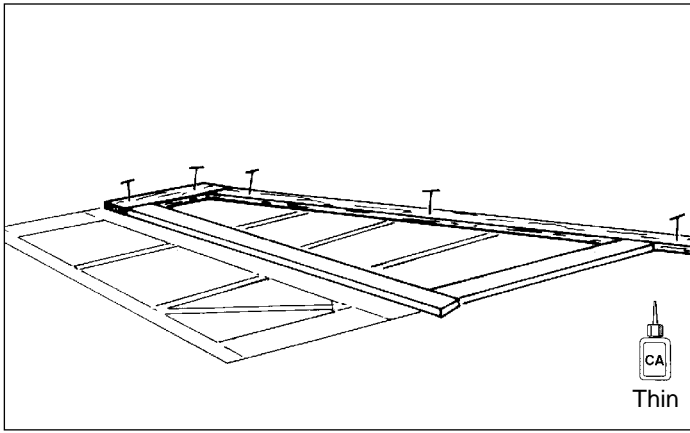

Step 17

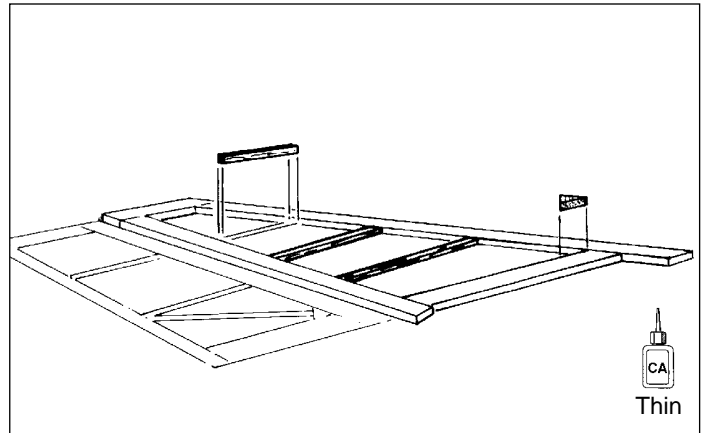

Step 18

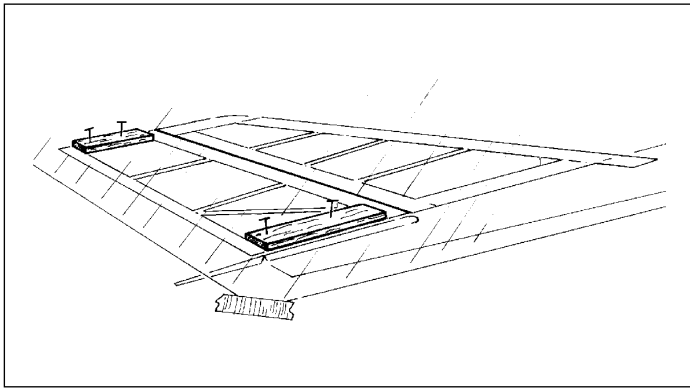

Step 19

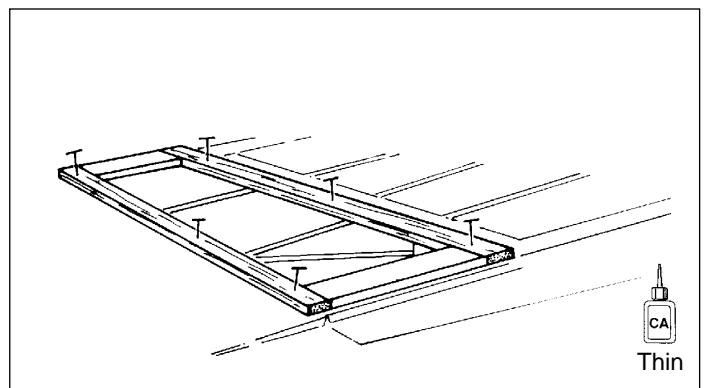

Step 20

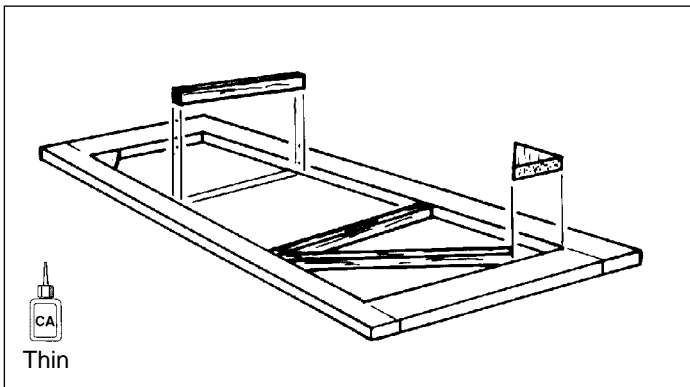

Step 21

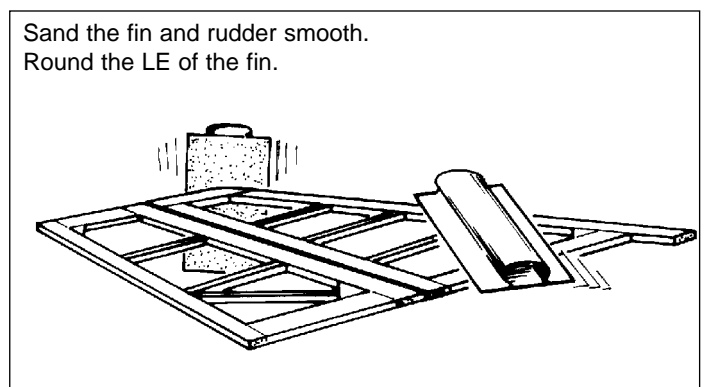

Step 22

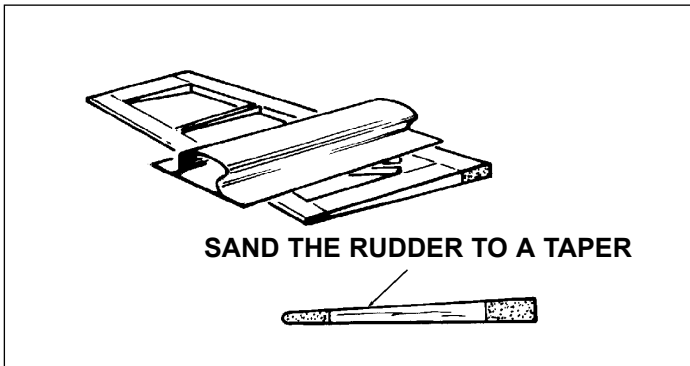

Step 23

ASSEMBLE THE FUSELAGE

Cover the fuselage plan with Great Planes Plan Protector or wax paper.

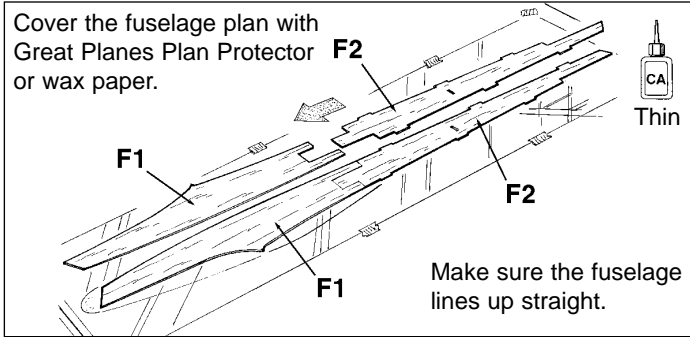

Step 1

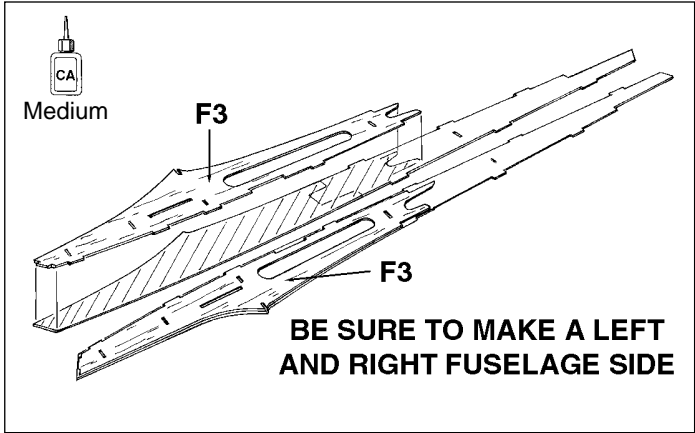

Step 2

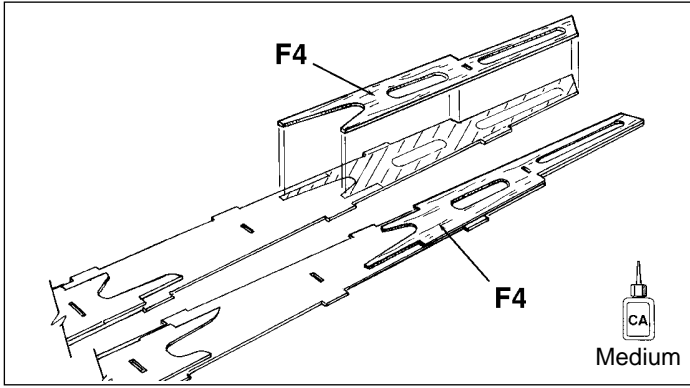

Step 3

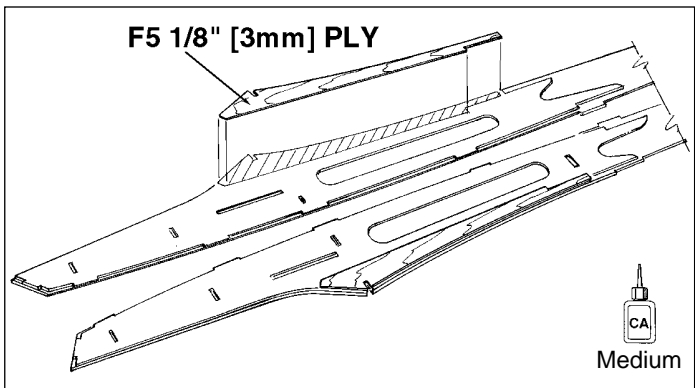

Step 4

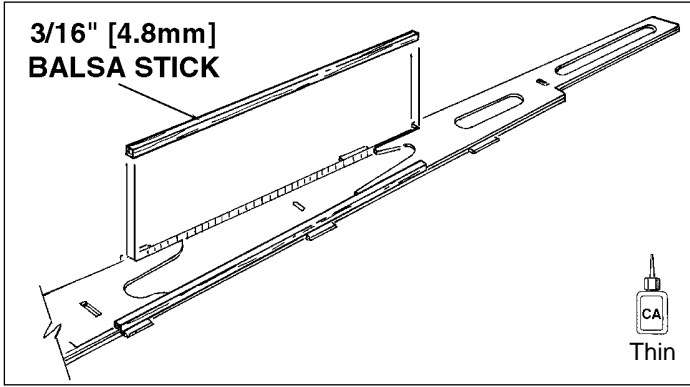

Step 5

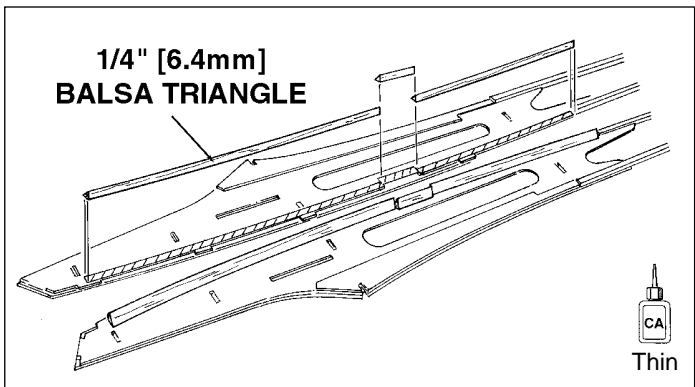

Step 6

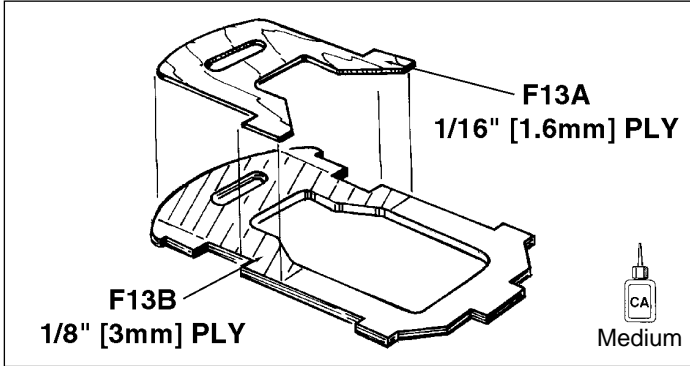

Step 7

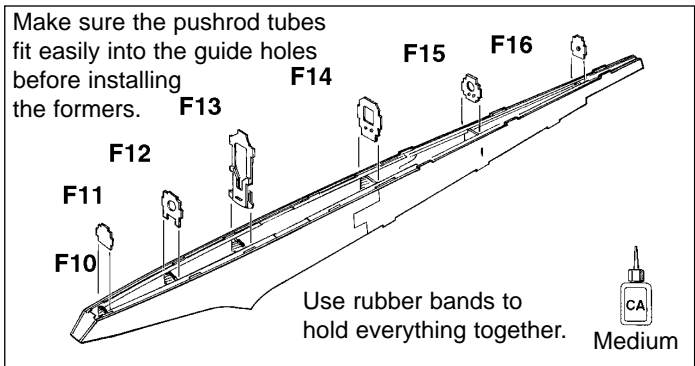

Step 8

Make sure the three punch marks on F9, face the inside of the fuselage.

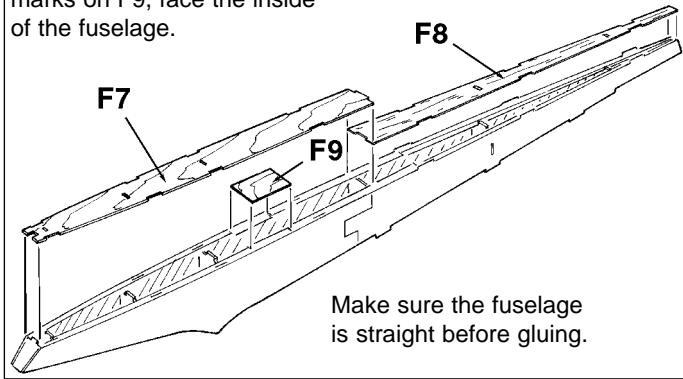

Make sure the fuselage is straight before gluing.

Step 9

Use rubber bands to hold the fuselage together. Make sure the fuselage is **straight** and then glue.

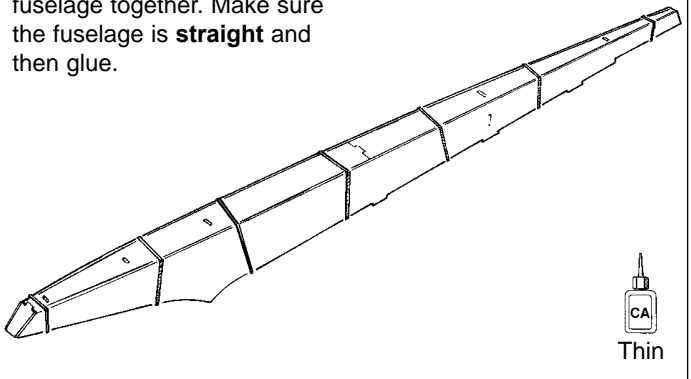

CA
Thin

Step 10

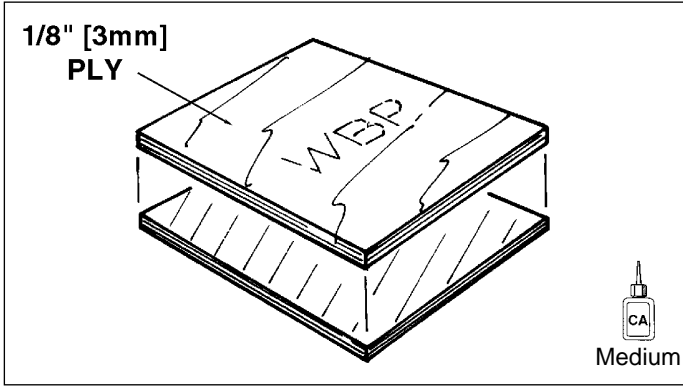

CA
Medium

Step 11

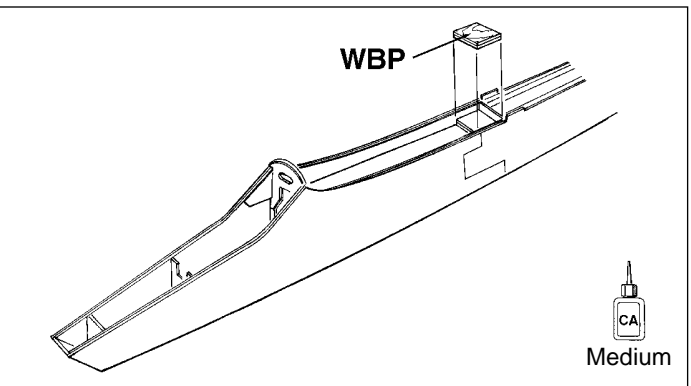

CA
Medium

Step 12

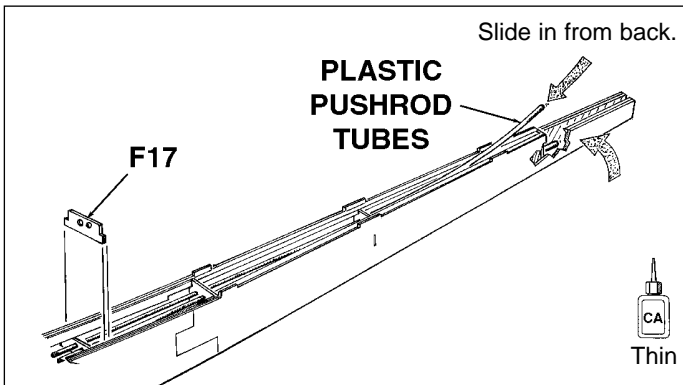

Slide in from back.

PLASTIC
PUSHROD
TUBES

CA
Thin

Step 13

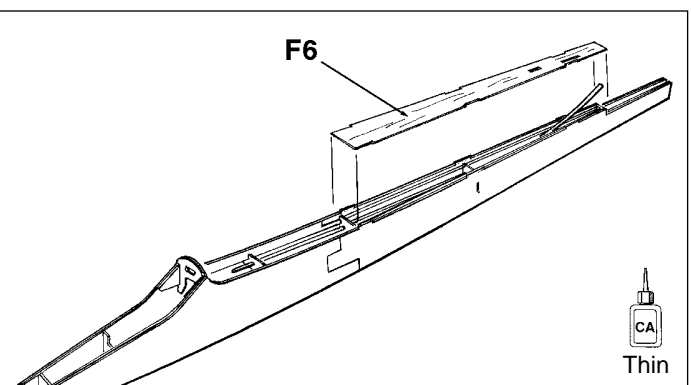

CA
Thin

Step 14

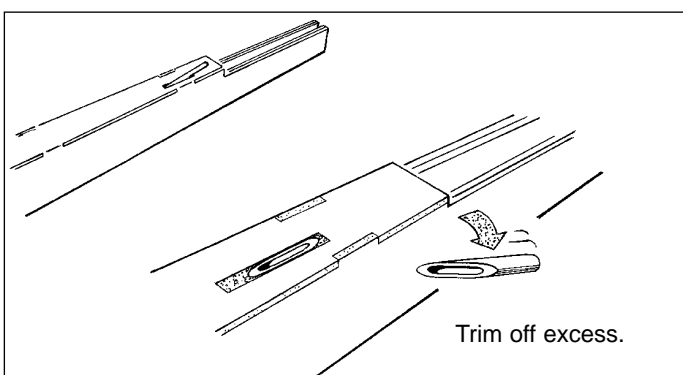

Trim off excess.

Step 15

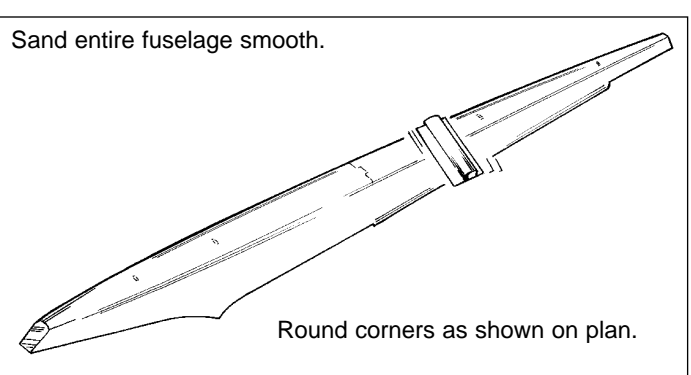

Sand entire fuselage smooth.

Round corners as shown on plan.

Step 16

BUILD THE WING

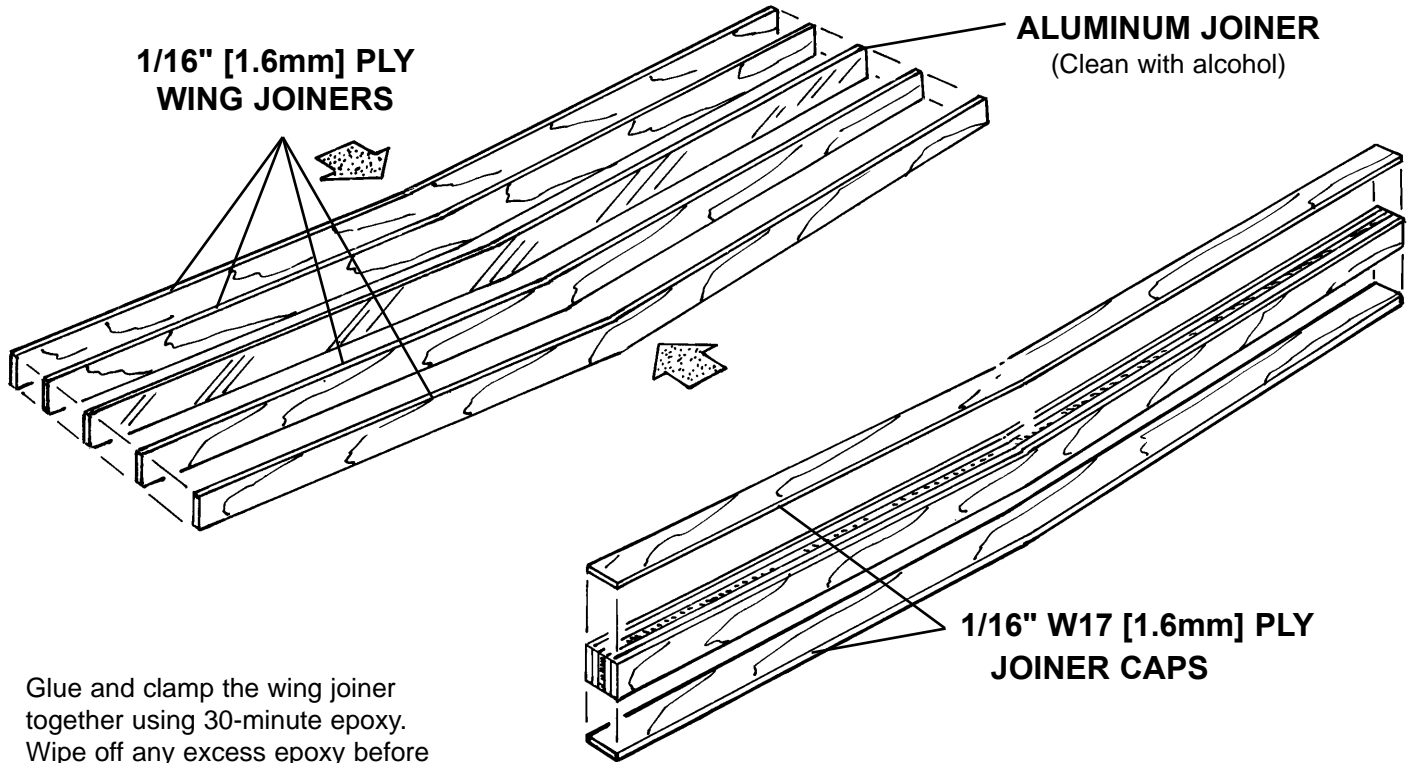

Glue and clamp the wing joiner together using 30-minute epoxy. Wipe off any excess epoxy before it cures.

Step 1

Cover the wing plan with Great Planes Plan Protector or wax paper.

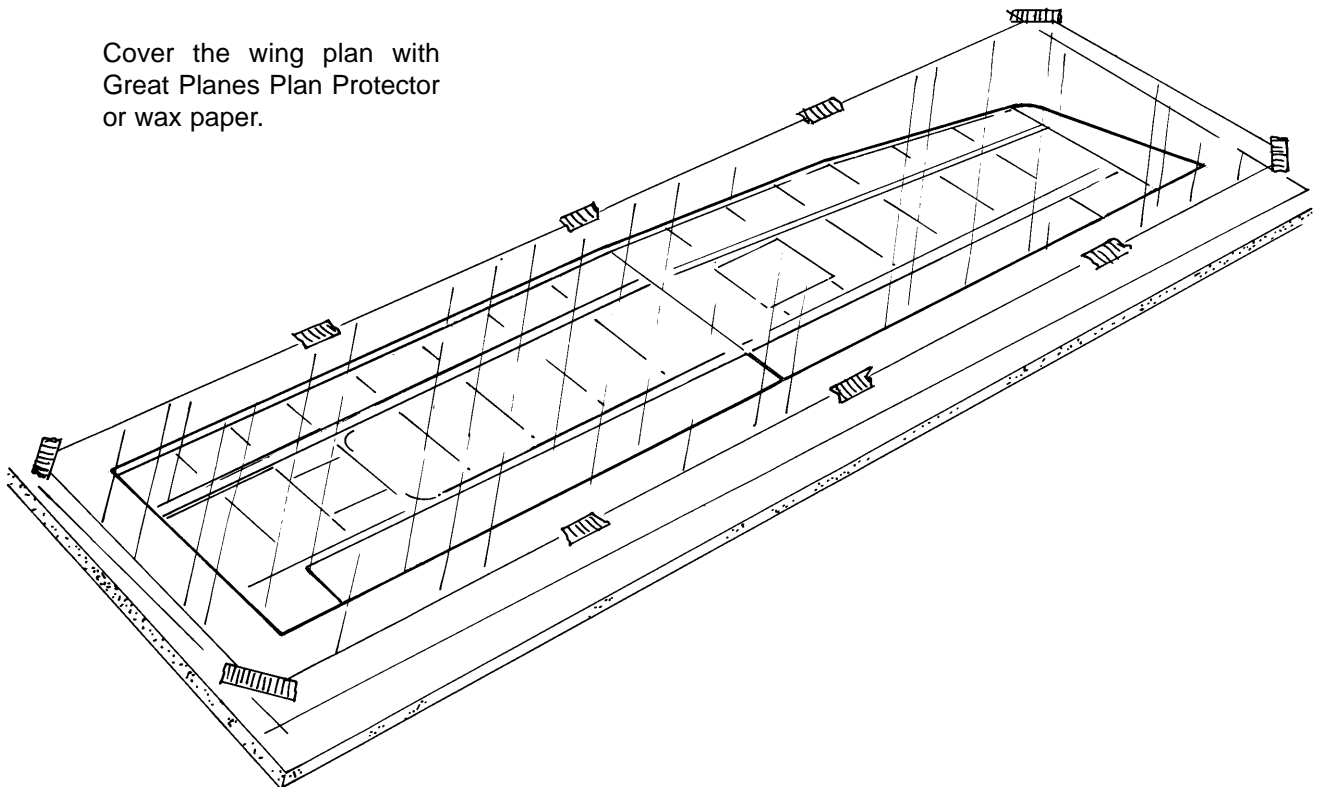

Step 2

Cut the 1/8" x 3/4" x 12-1/2"
[3.2mm x 19mm x 317mm]
plywood to make the joiner
box parts

1/8" [3.2mm]
PLY JOINER BOX

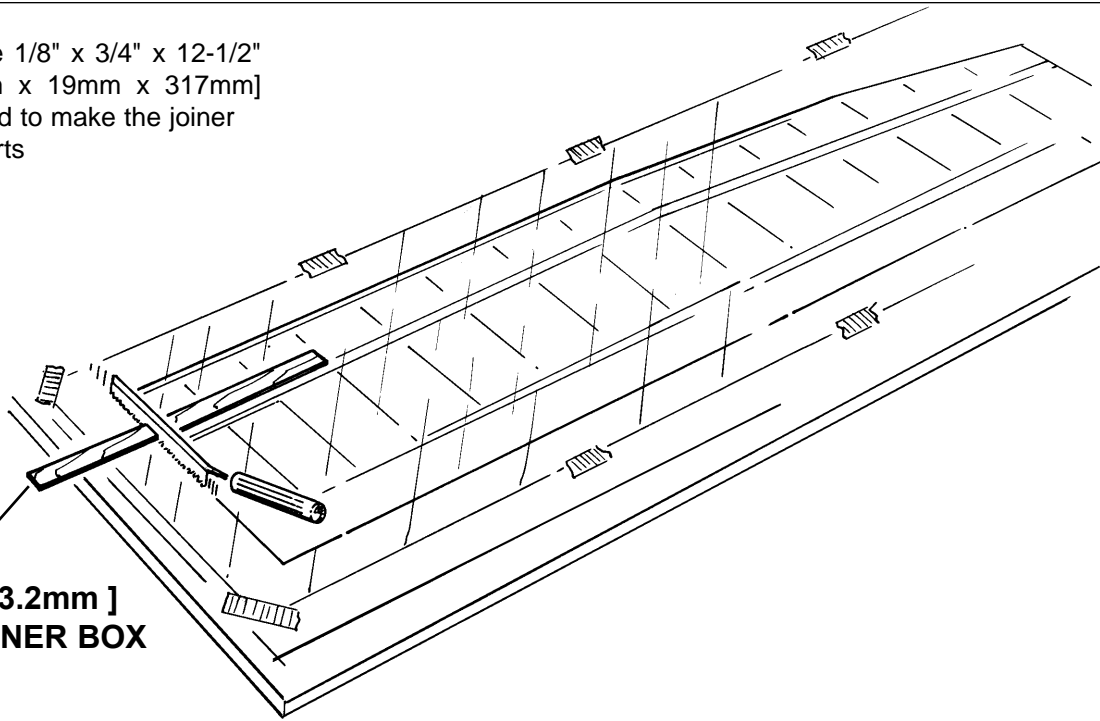

Step 3

Position the 1/8" x 5/16" x 40"
[3.2mm x 8mm x 1016mm]
spars over the plan.
Cut the spars at rib 9.

Leave
1/4" [6.4mm]
overhang.

Step 4

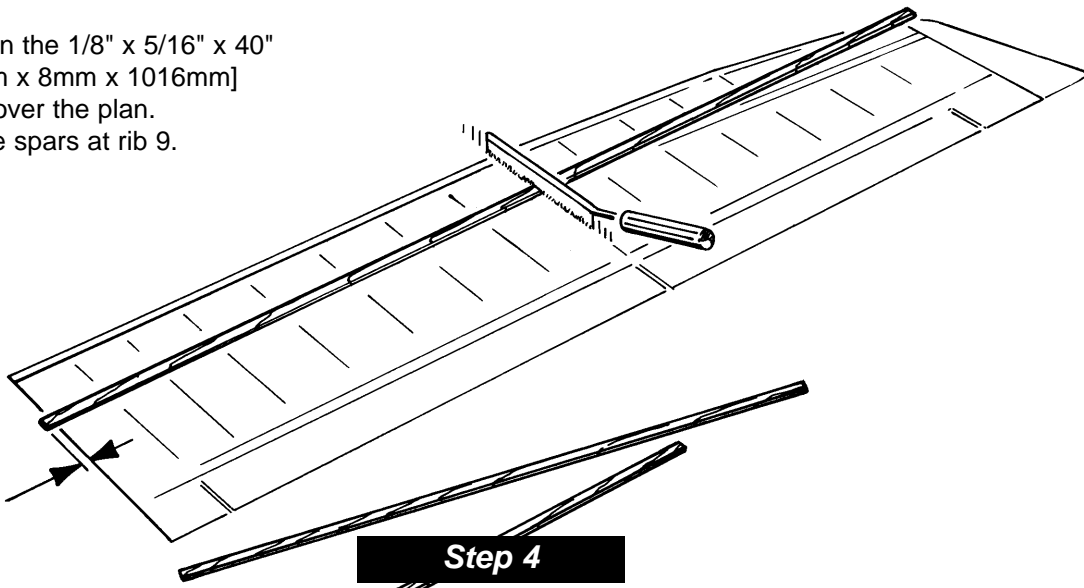

W23

Cut the W23 balsa
shear web at rib 9.

Step 5

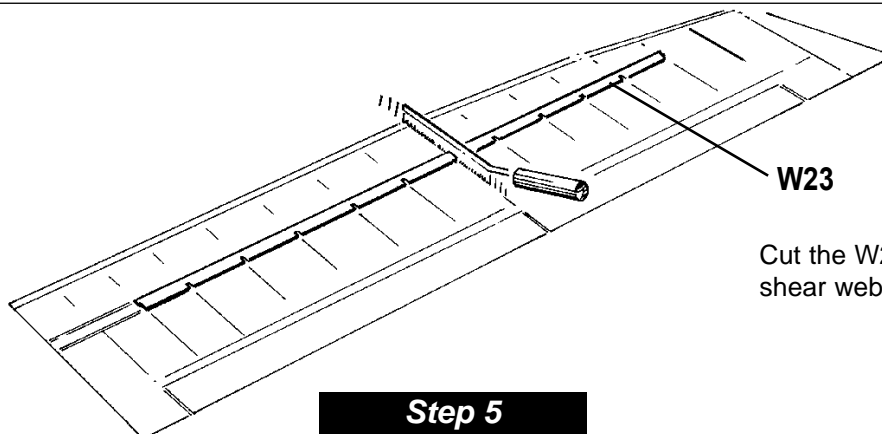

**BUILD THE
INBOARD PANEL**

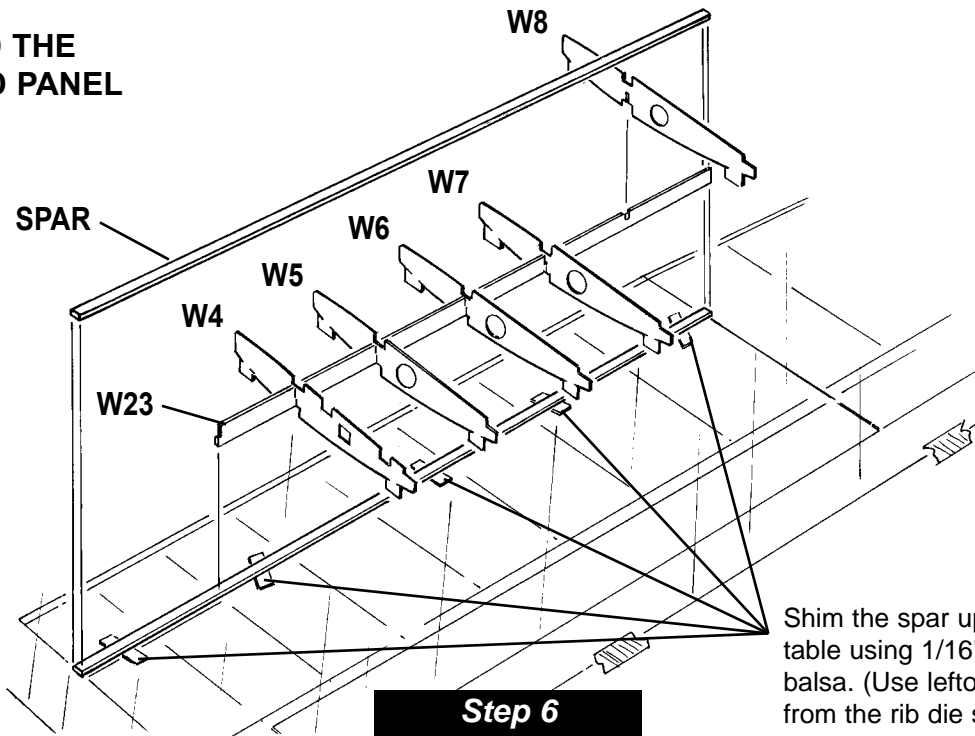

Shim the spar up from the table using 1/16" [1.6mm] balsa. (Use leftover pieces from the rib die sheets.)

Step 6

**3/16" [4.8mm] SQUARE
BALSA RIB JIGS**

Use pieces of the 3/16" x 3/16" balsa sticks as rib jigs to hold the ribs in place for the steps that follow.

Step 7

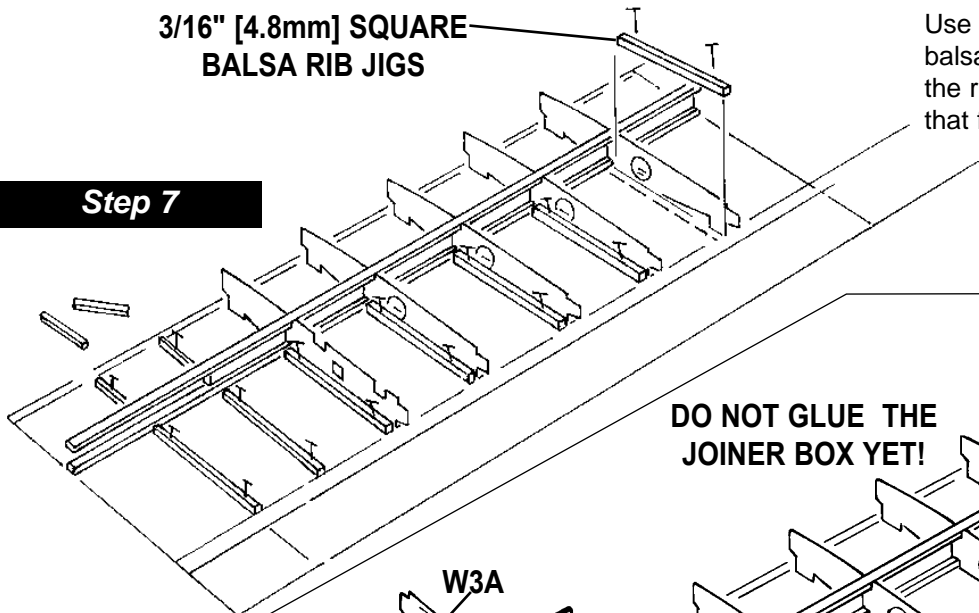

**DO NOT GLUE THE
JOINER BOX YET!**

**1/8" [3.2mm] JOINER
BOX FRONT**

Clamp the 1/8" [3.2mm] joiner box front and joiner box aft to the spars.

**1/8" [3.2mm] JOINER
BOX AFT**

Add ribs 2A&B.
Add ribs 3A&B.

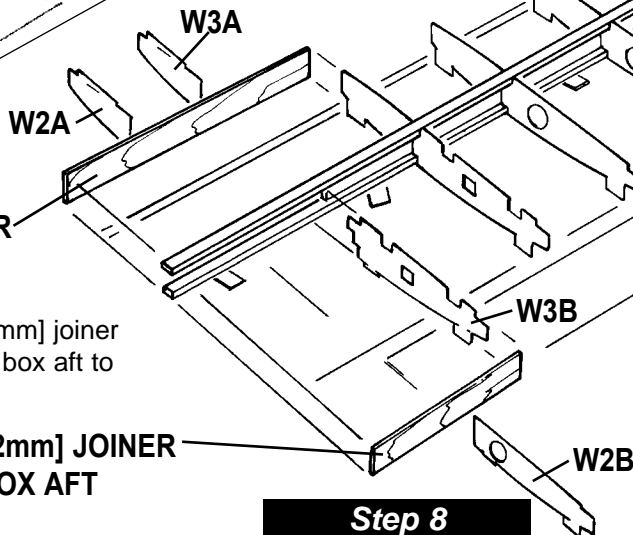

Step 8

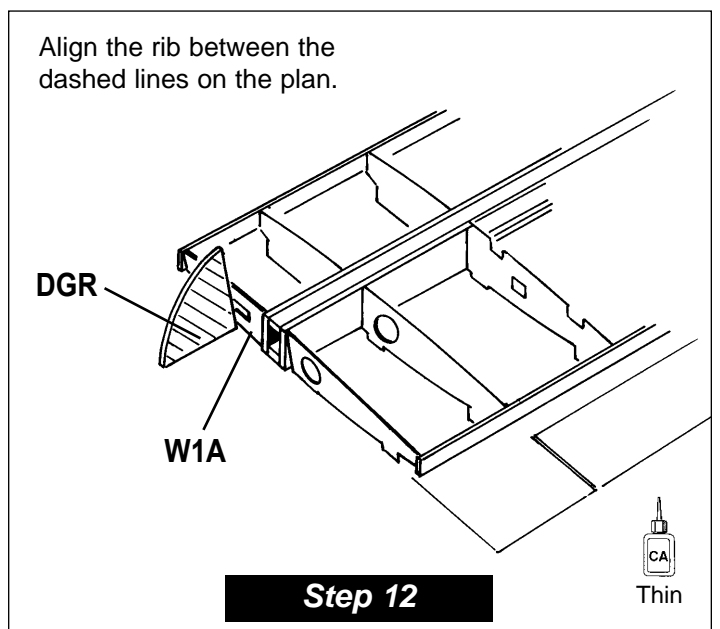
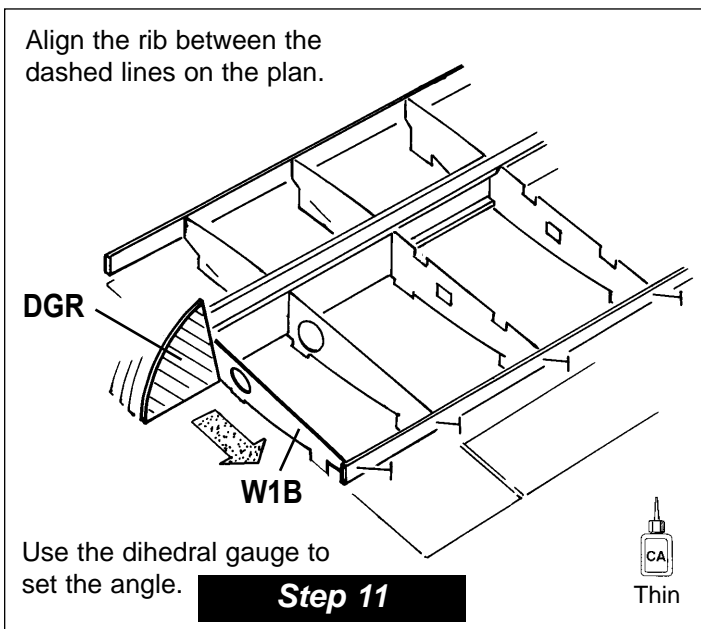
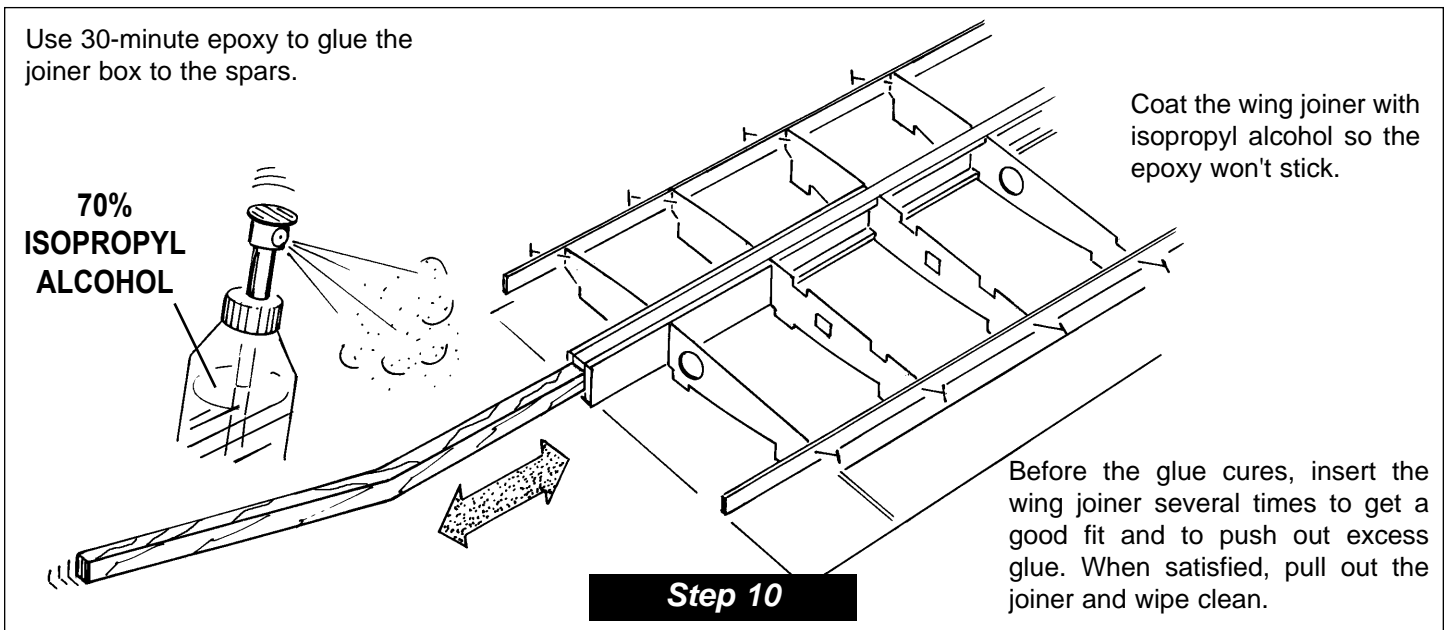
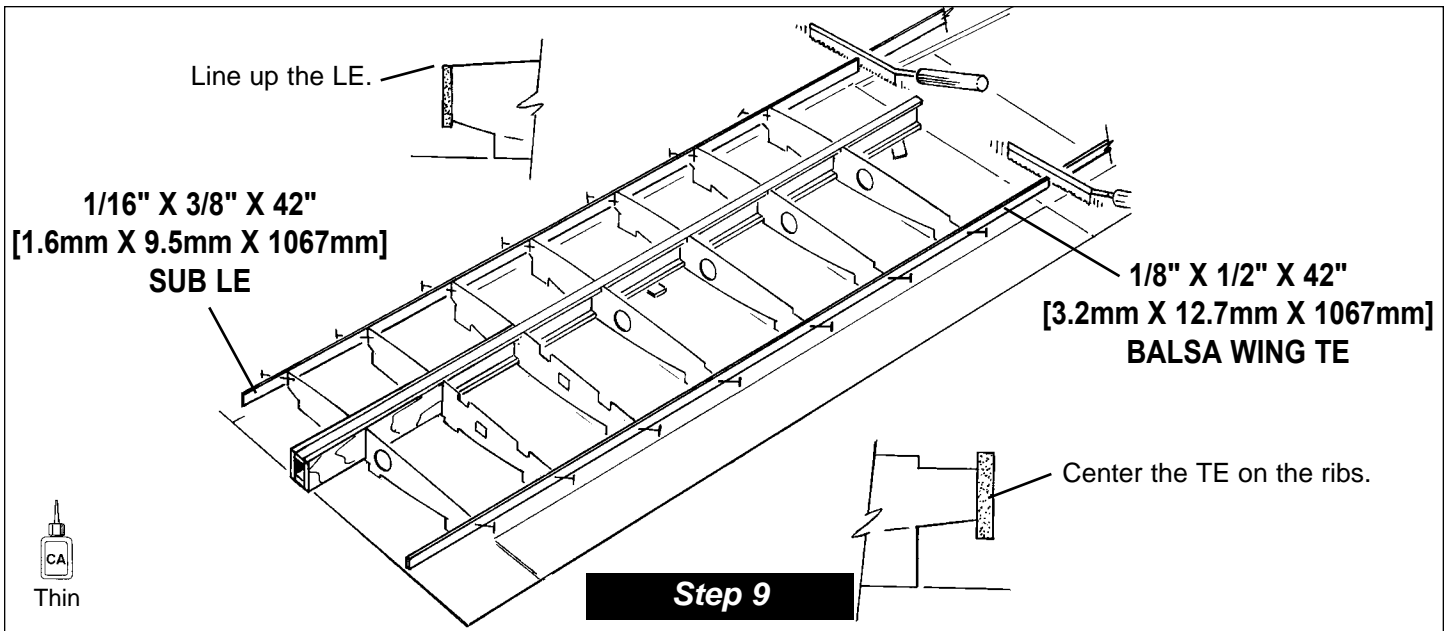

POLYHEDRAL WING

Use the polyhedral gauge only if you are building the polyhedral wing.

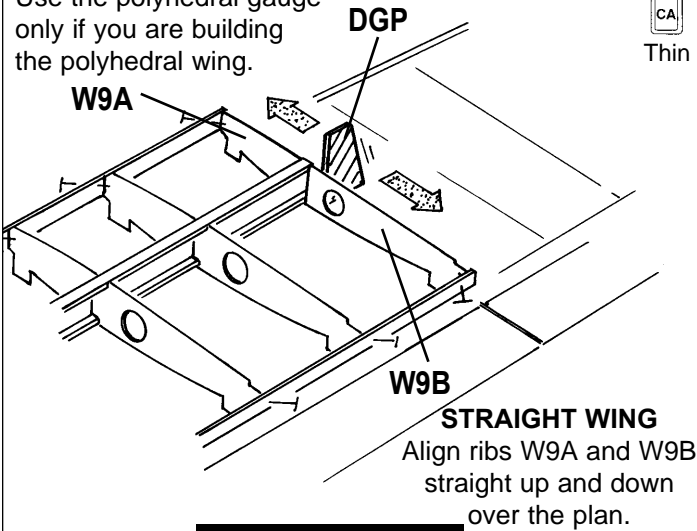

Step 13

Cut the fiberglass cloth into four 4" [100mm] pieces. Attach part of the fiberglass cloth to the spars using thin CA. You will finish this step after you remove the panel from the table.

FIBERGLASS CLOTH

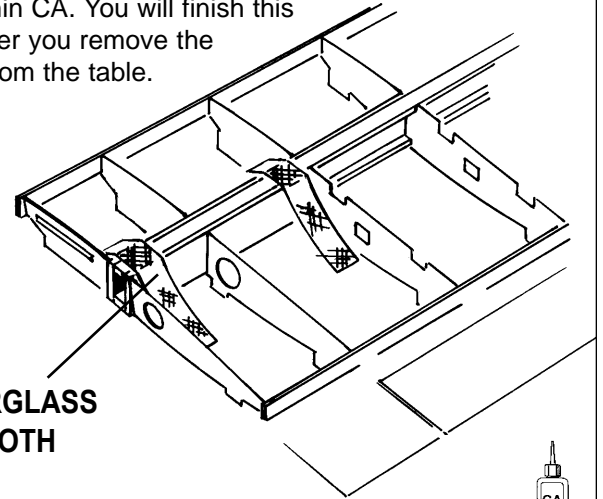

Step 14

1/16" X 3" X 24"
[1.6mm X 76mm X 610mm]
BALSA SHEET

Fill in any gaps with 1/16" [1.6mm] balsa.

Sand the sheeting so it doesn't bulge at the cloth.

1/16" X 3/8" X 42"
[1.6mm X 9.5mm X 1067mm]
BALSA TE SHEETING

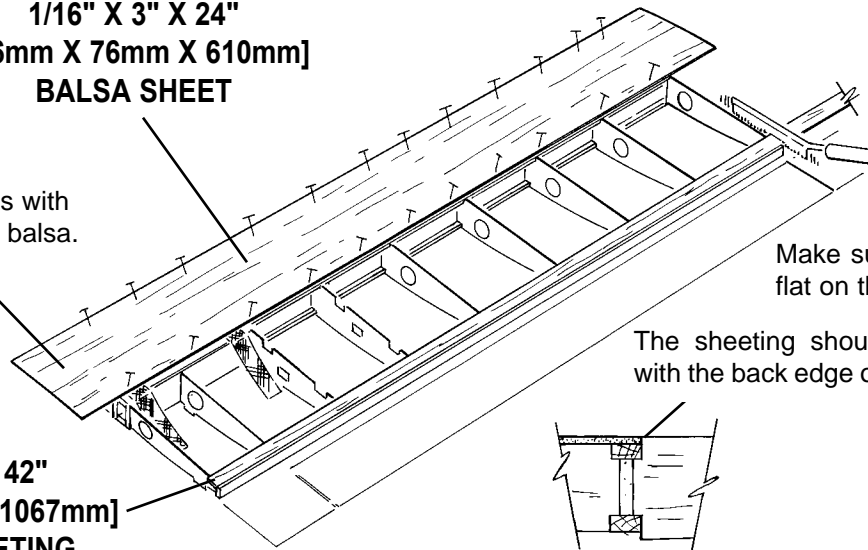

Step 15

Cut the rails in half.

3/16" X 3/8" X 5-1/2"
[4.8mm X 9.5mm X 140mm]
BASSWOOD RAILS

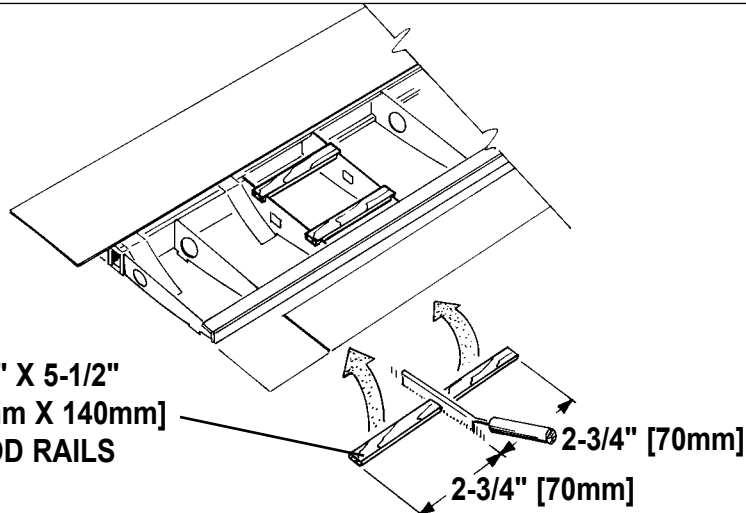

Step 16

1/16" X 3" X 24"
[1.6mm X 76mm X 610mm]
BALSA SHEET

Use the ply hatch as a template for cutting the hole for the flap servo.

W20 1/16" [1.6mm]
PLY HATCH

Step 17

CA
 Medium

Cut from 1/16" X 3" X 24"
[1.6mm X 76mm X 610mm]
BALSA SHEET

Step 18

CA
 Medium

Remove the wing from the table. Cut off the jig tabs and sand smooth.

Step 19

Wrap the fiberglass cloth tightly around the joiner box and glue it in place. Cut off any excess.

Step 20

CA
 Thin

CA
 Medium
 or
 aliphatic
 wood
 glue

1/16" X 3" X 24"
[1.6mm X 76mm X 610mm]
BALSA SHEET

Glue the top sheeting in place.

1/16" X 3/8" X 42"
[1.6mm X 9.5mm X 1067mm]
BALSA SHEETING

The cloth will cause the sheeting to bulge. sand the sheeting to compensate.

Step 21

1/16" X 3" X 24"
[1.6mm X 76mm X 610mm]
BALSA SHEET

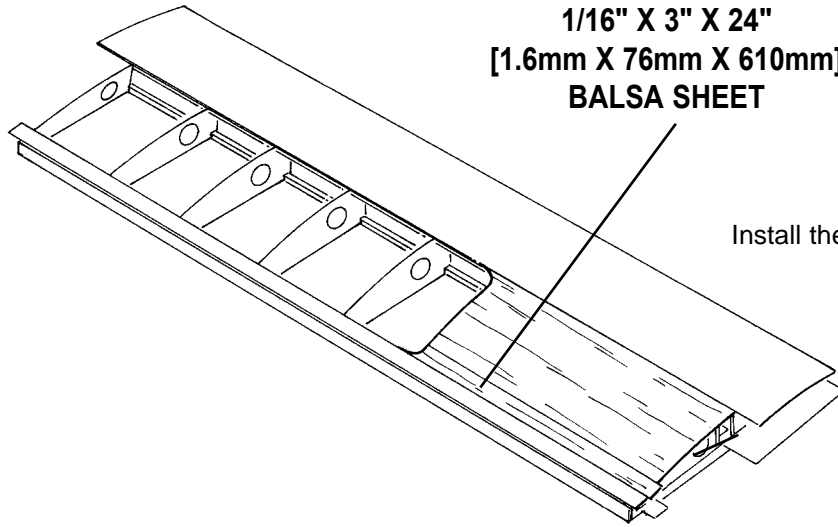

Install the top center sheeting.

Step 22



Trim off and sand the leading edge smooth.

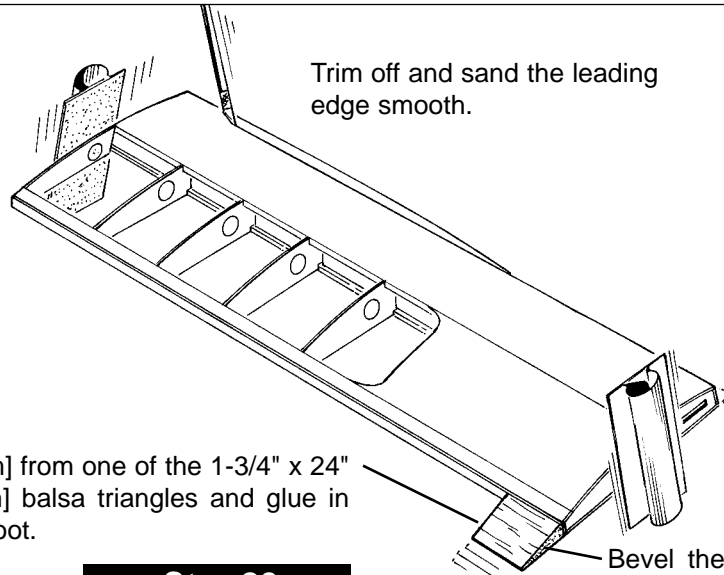

Cut 2-1/2" [63.5mm] from one of the 1-3/4" x 24" [44.4mm x 610mm] balsa triangles and glue in place at the wing root.

Sand the root and the outer ribs smooth.

Bevel the leading edge so the balsa will follow the shape of the rib.

Step 23

Finish the slot in W1A for the wing dowel.

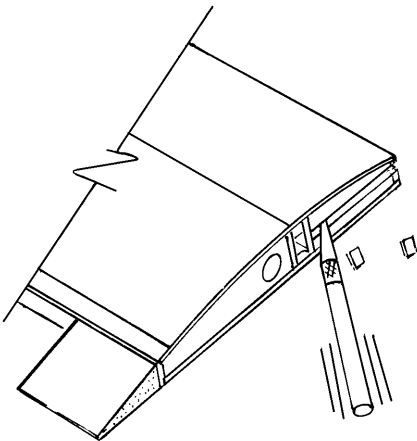

Step 24

Epoxy the wing dowel and W1C to the wing root.

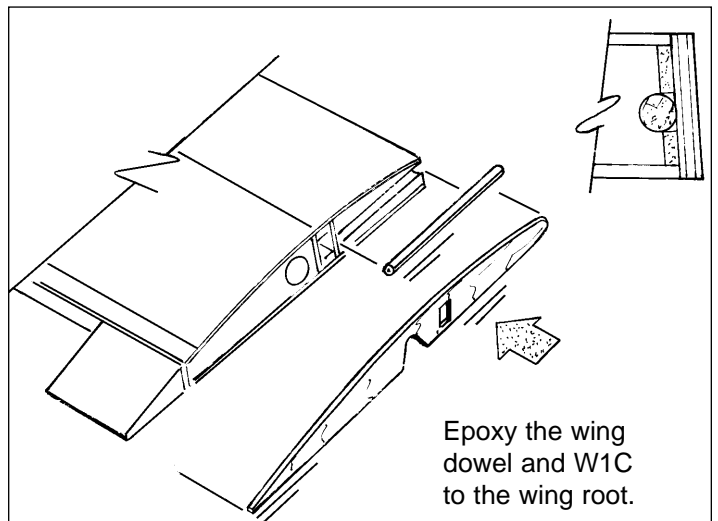

Step 25

BUILD THE OUTER PANEL

Position the 1/8" [3.2mm] spars over the plan.

1/8" [3.2mm]

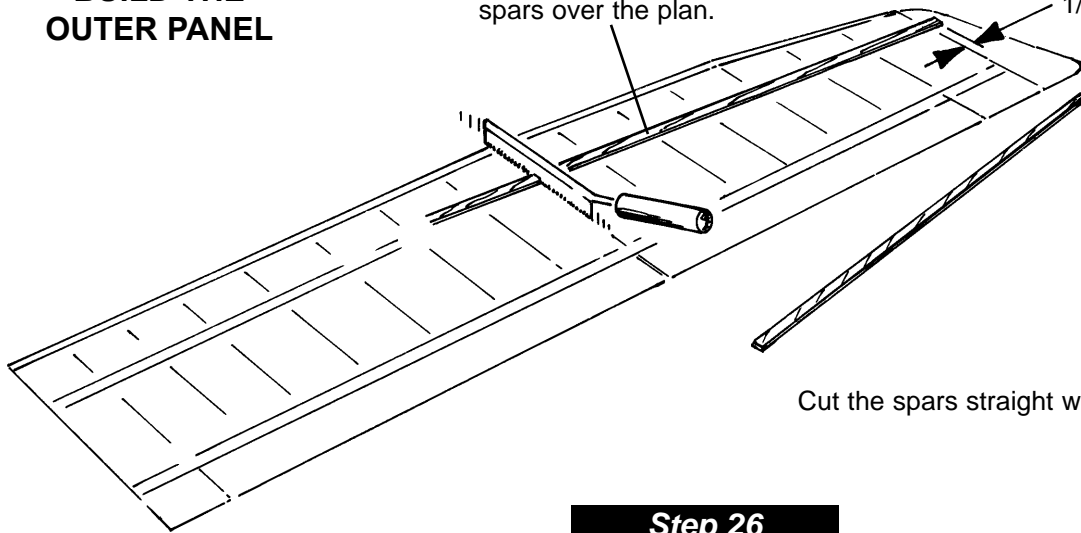

Cut the spars straight with rib 9.

Step 26

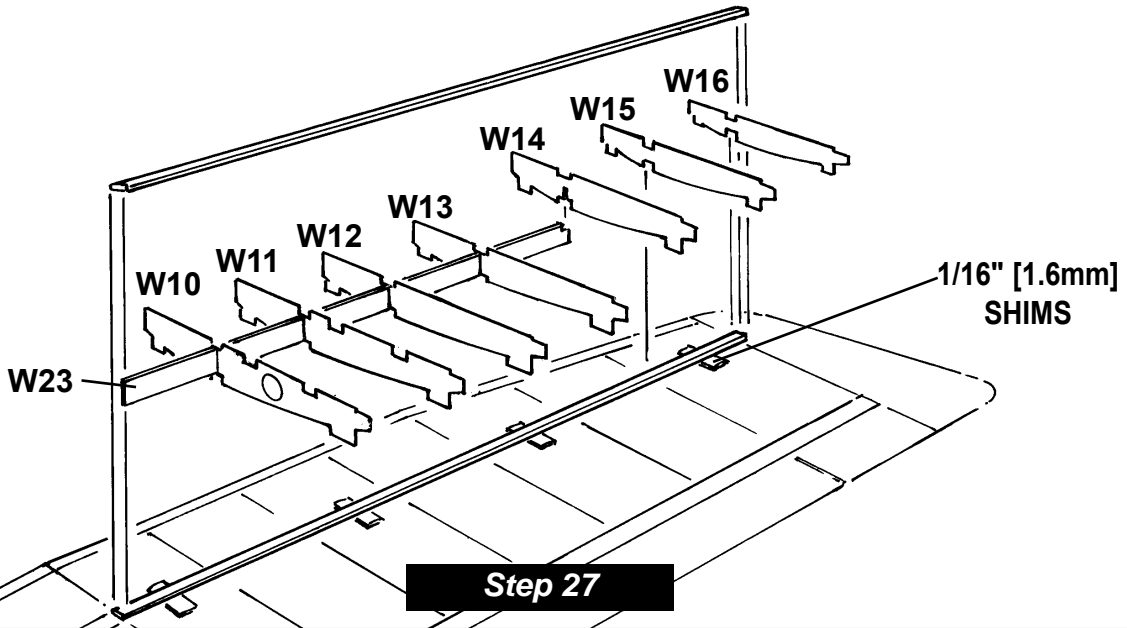

Step 27

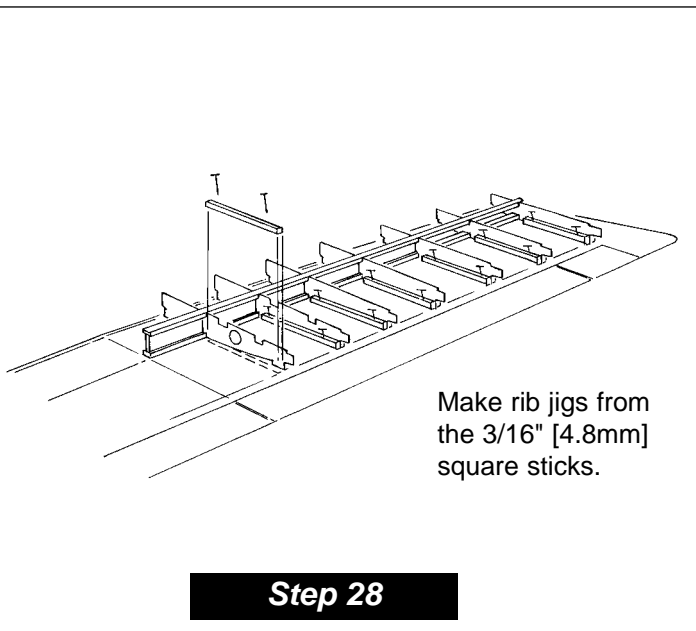

Make rib jigs from the 3/16" [4.8mm] square sticks.

Step 28

1/16" X 3/8" X 42" [1.6mm X 9.5mm X 1067mm] Balsa LE

(Left over from the inner panel.)

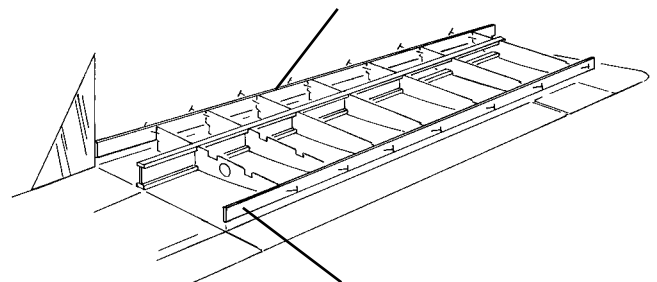

1/8" X 1/2" X 42" [1.6mm X 9.5mm X 1067mm] Balsa TE

(Left over from the inner panel.)



Step 29

1/16" X 3" X 24"
[1.6mm X 76mm X 610mm]
BALSA SHEETING

1/16" X 3/8" X 42"
[1.6mm X 9.5mm X 1067mm]
BALSA TE SHEETING

Medium
or
aliphatic
wood
glue

Step 30

Install the servo rails.
Cut from 3/16" x 3/8" x 5-1/2" basswood.

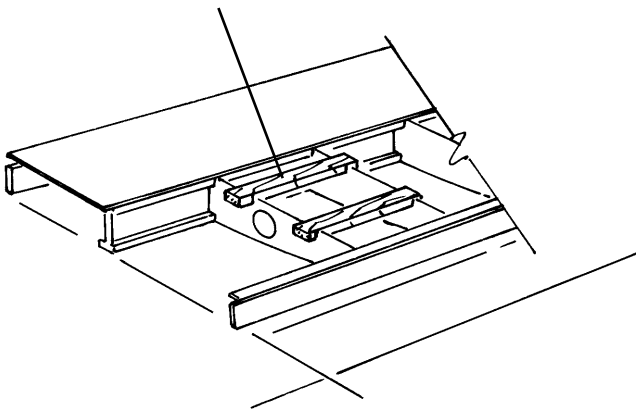

Medium

Step 31

Install 1/16" [1.6mm] balsa sheeting
around the servo hatch.

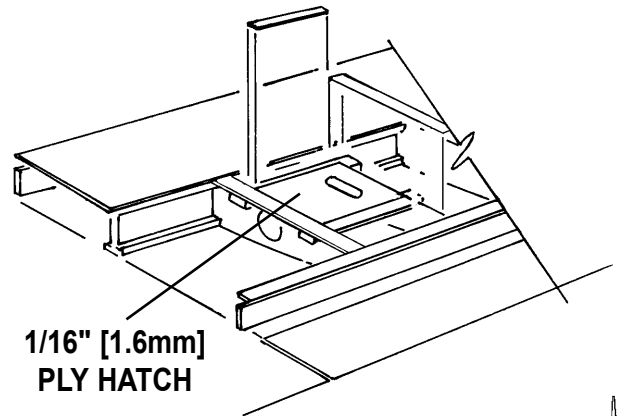

1/16" [1.6mm]
PLY HATCH

Thin

Step 32

Cut a small gusset from
3/8" [9.5mm] balsa.

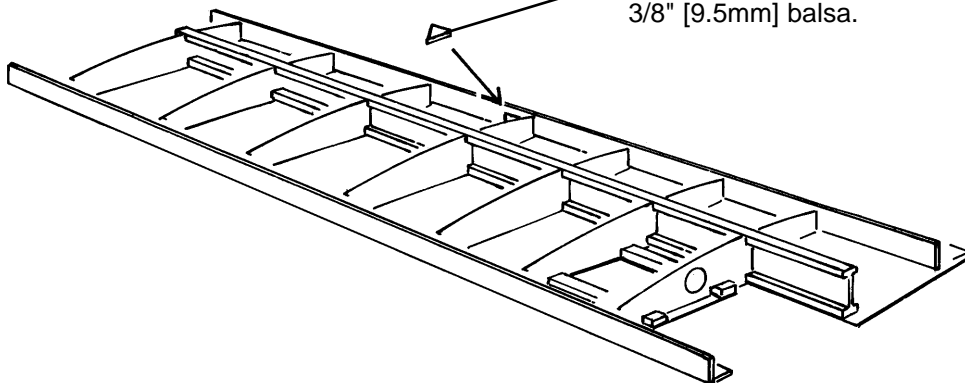

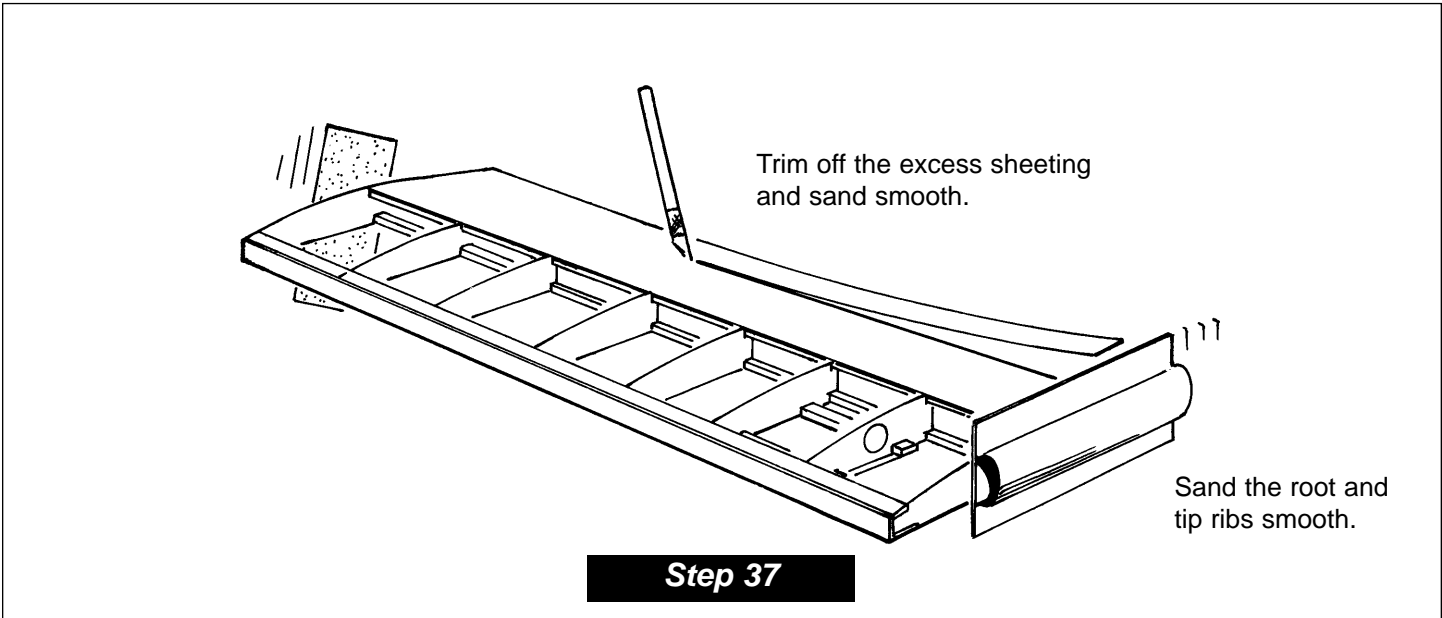
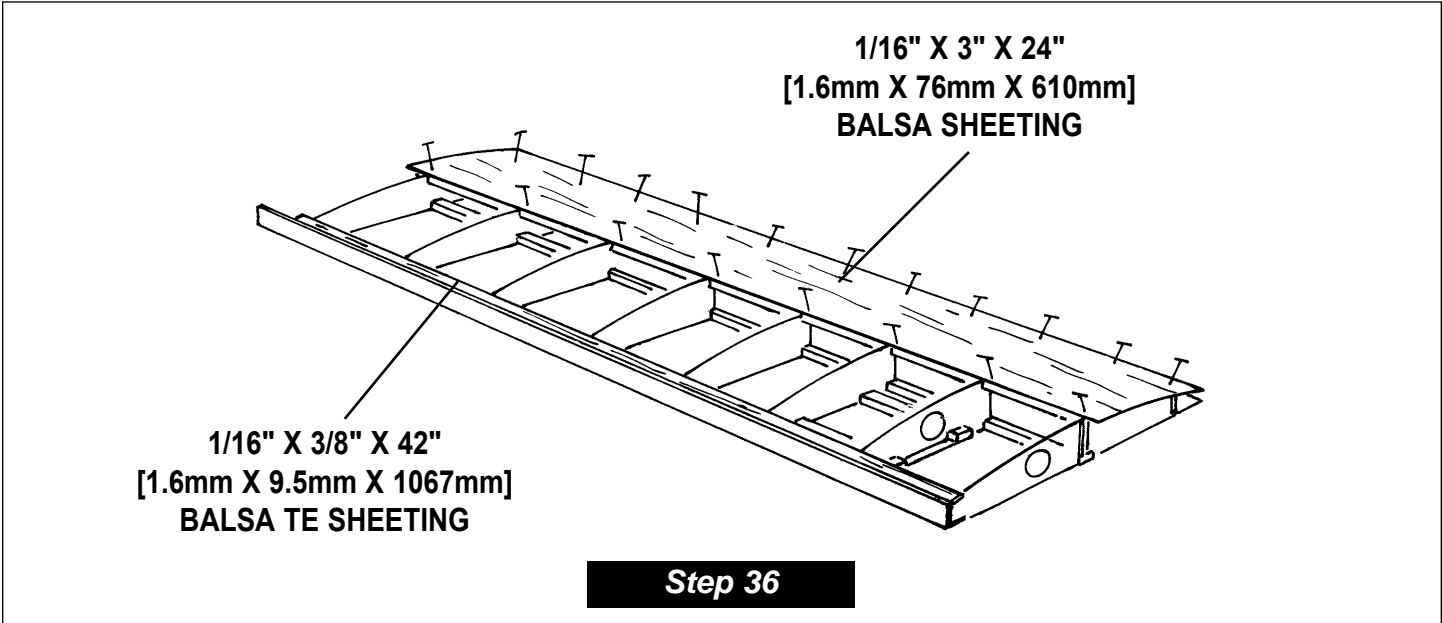
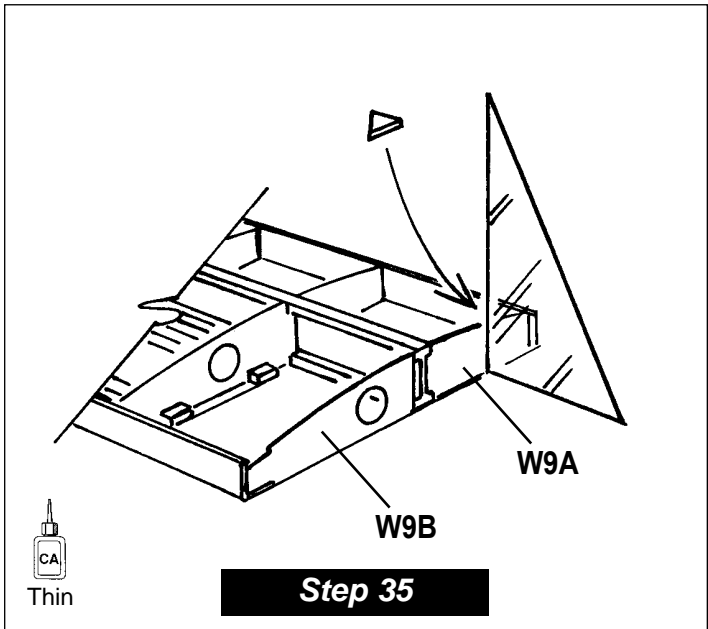
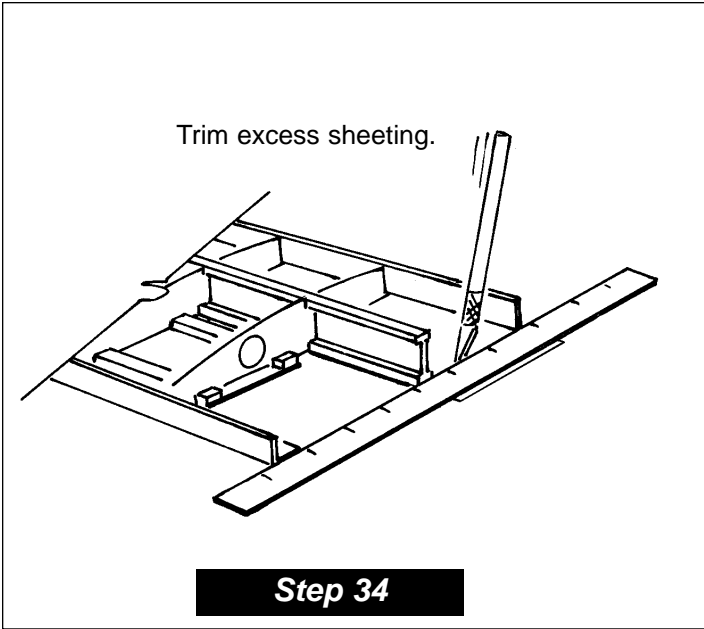

Thin

Step 33

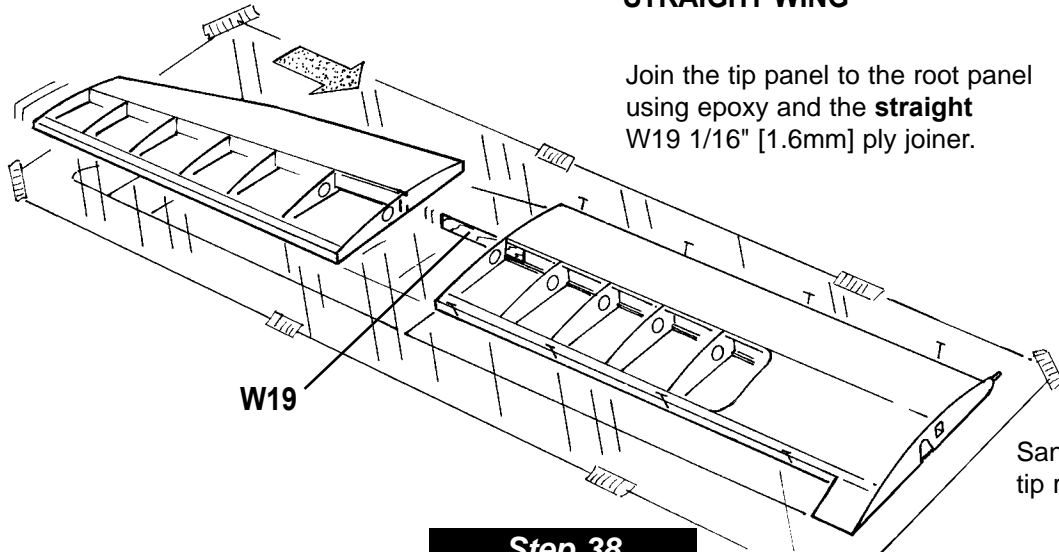

STRAIGHT WING

Join the tip panel to the root panel using epoxy and the **straight** W19 1/16" [1.6mm] ply joiner.



Sand the root and tip ribs smooth.

Step 38

POLYHEDRAL WING

Join the tip panel to the root panel using epoxy and the W18 1/16" [1.6mm] ply joiner.

Use the (DGP) gauge under the W16 rib to help set the height.

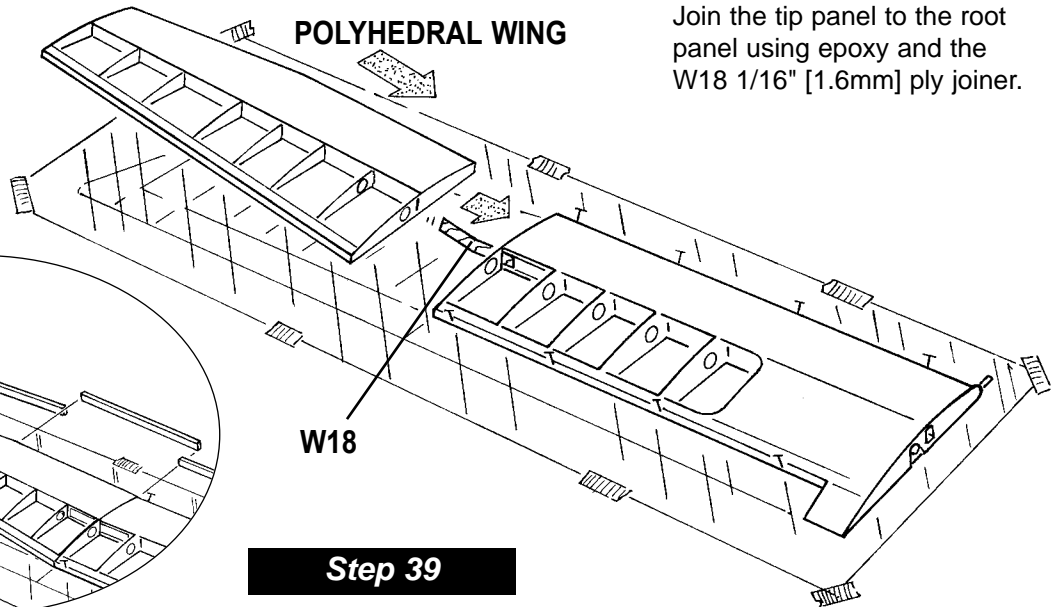
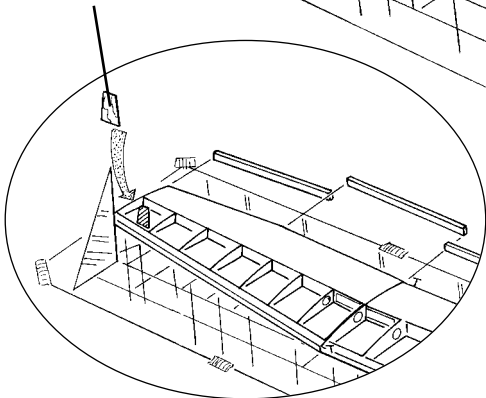

Step 39

Shape the LE as shown on the plan.

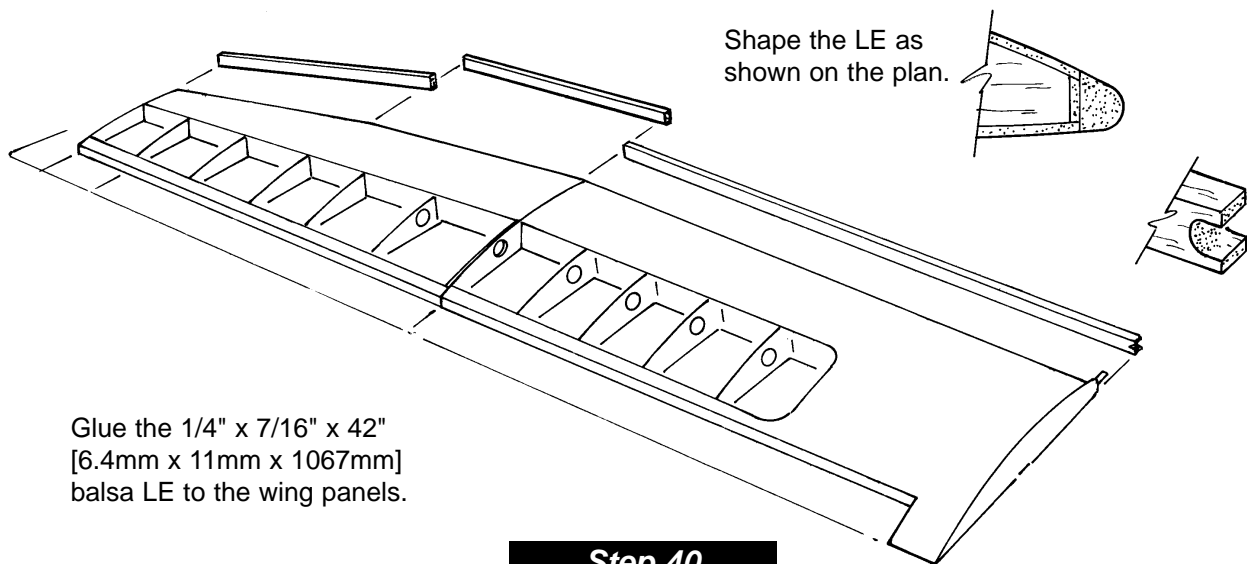

Glue the 1/4" x 7/16" x 42" [6.4mm x 11mm x 1067mm] balsa LE to the wing panels.

Step 40

Cut 2-1/2" [63.5mm] from a 1-3/4" x 24" [44.4mm x 610mm] balsa triangle.

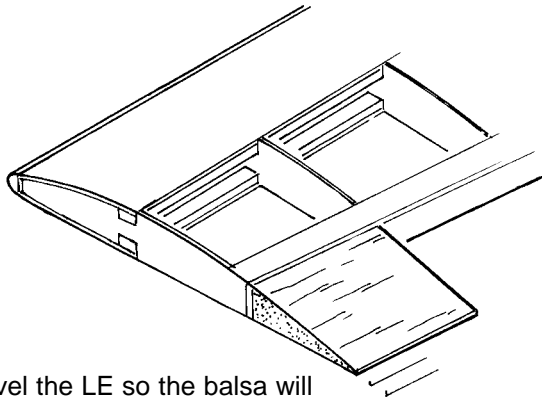

Bevel the LE so the balsa will follow the shape of the rib.

Step 41



Medium

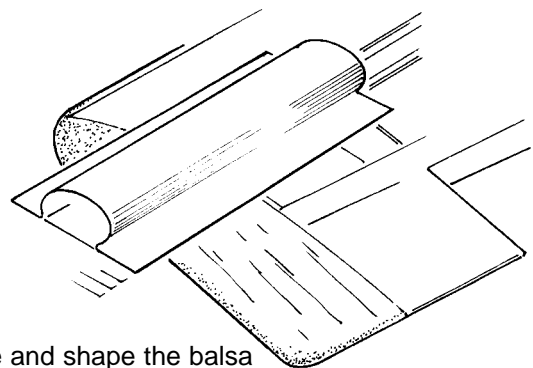

Glue and shape the balsa wing tip to the tip panel.

Step 42



Medium

Make an aileron and a flap from the leftover 1-3/4" [44.4mm] balsa triangles. Bevel their leading edges as shown on the plan.

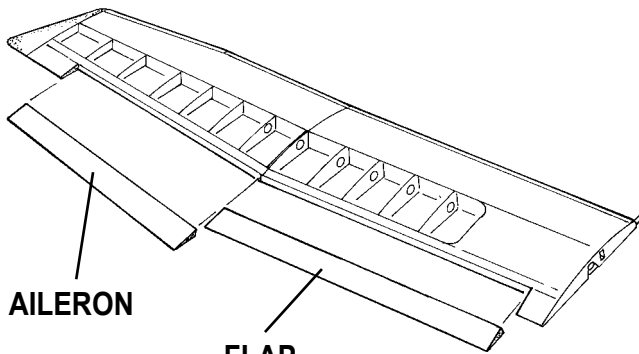

AILERON

FLAP

Step 43

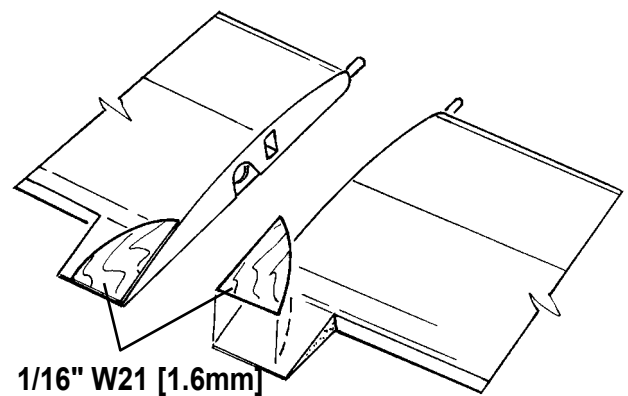

1/16" W21 [1.6mm]
PLY WING BOLT
PLATES

Step 44



Medium

Align the wing to the fuselage.

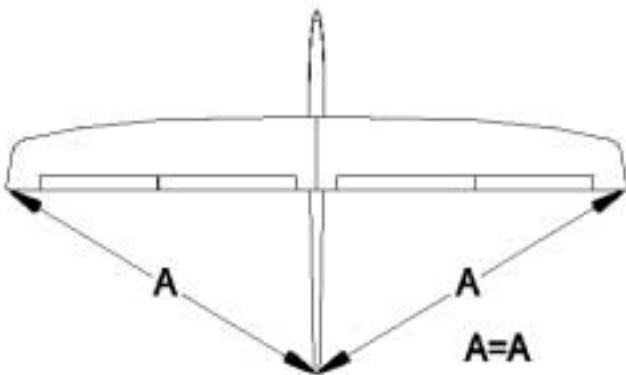

Step 45

Drill two 5/32" [4mm] holes through the wing and into the fuselage.

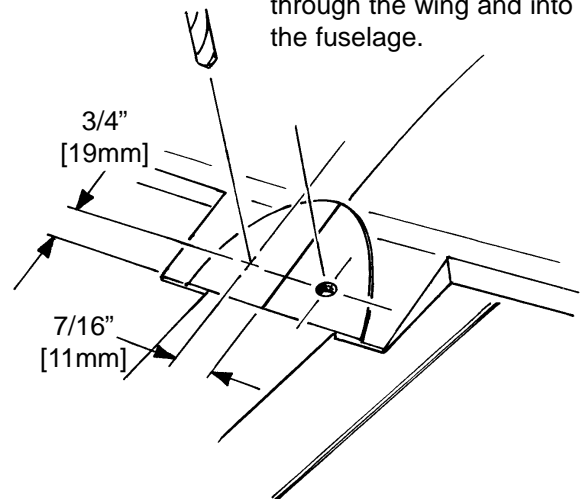

Step 46

Carefully tap the two holes. Reinforce the threads with thin CA and retap.

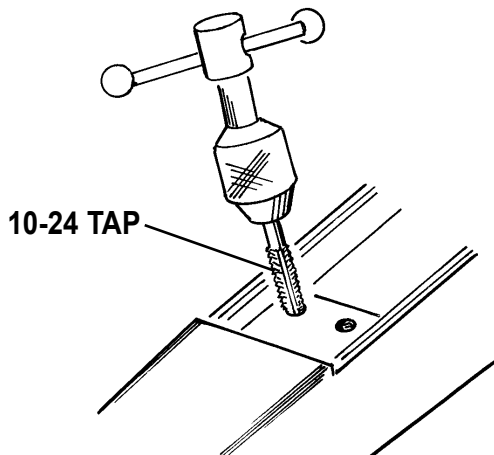

10-24 TAP

Step 47



Enlarge the holes in the wing.

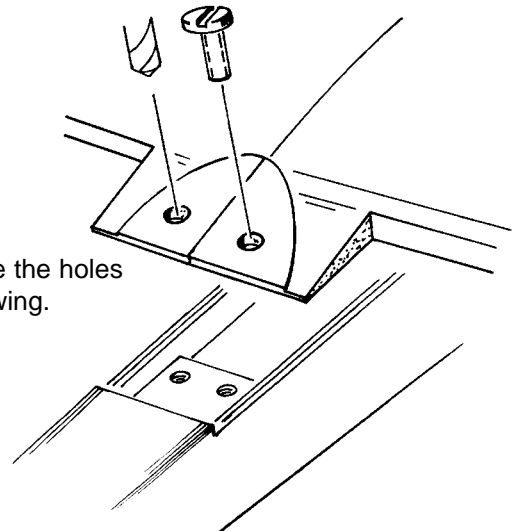

Step 48

FINISHING

Build the canopy.

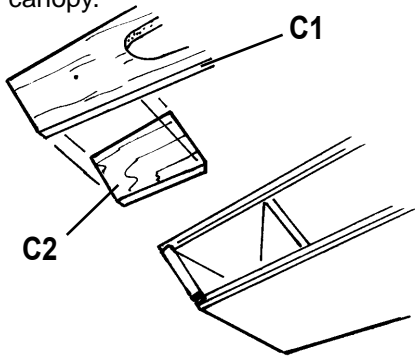

Glue the plywood C2 doubler to C1 balsa canopy base.

Step 1



Glue the canopy parts together. Be careful not to glue them to the fuselage.

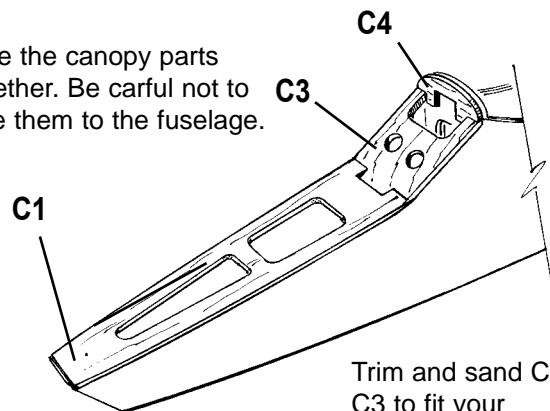

Trim and sand C1 and C3 to fit your

Step 2

BALSA NOSE BLOCK

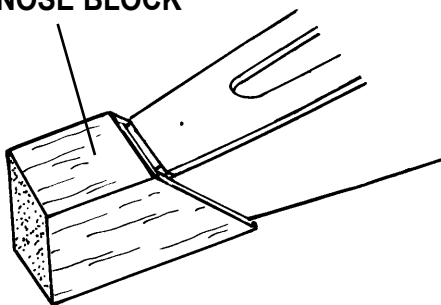

Step 3

1/8" [3mm]
DRILL BIT

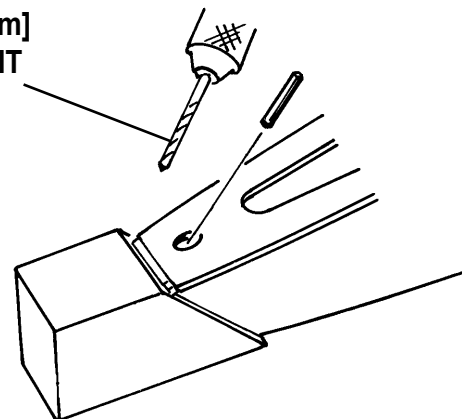

Drill a 1/8" [3mm] hole into the nose block. Glue in the 1/8" x 1" [3mm x 25.4mm] dowel into the canopy base. Do not glue the dowel to the fuselage.

Step 4



Trim the plastic canopy to fit the canopy frame and fuselage.

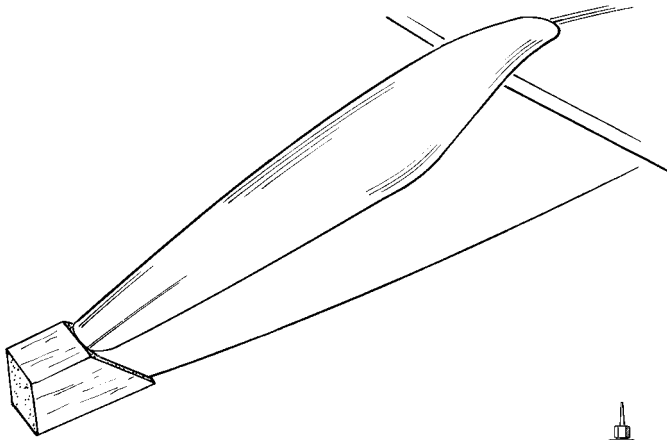

Step 5



Sand the nose block to shape.
(See plan)

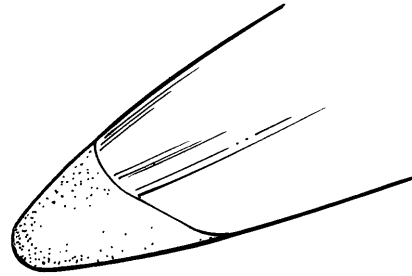

Step 6

2 X 3/8" [9.5mm] SCREW

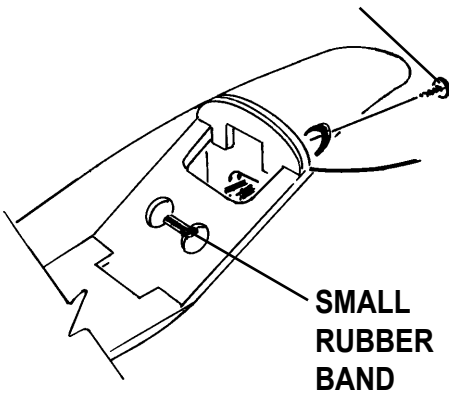

SMALL RUBBER BAND

Step 7

Drill 3 holes in F9 - 1/16" [1.6mm] ply tow hook mount.

1/8" [3mm] DRILL BIT

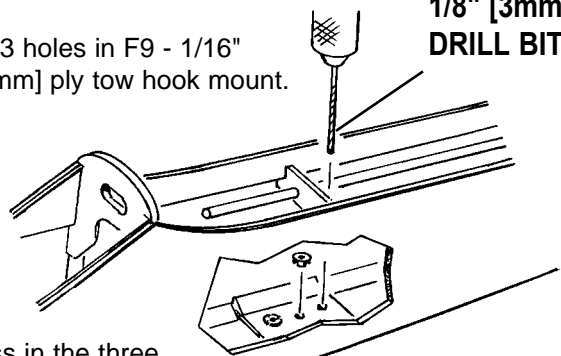

Press in the three blind nuts.

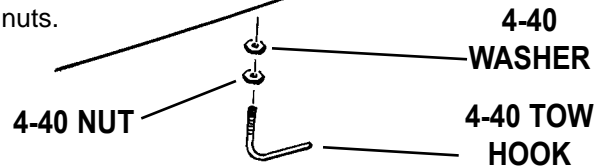

Step 8

HINGE THE RUDDER

Mark a center line on the fin and rudder.

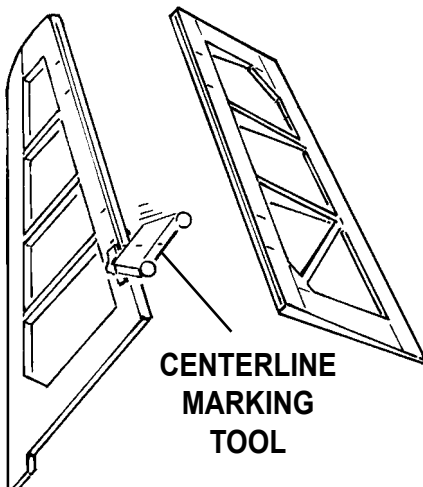

CENTERLINE MARKING TOOL

Step 9

Cut two 3/4" x 1" [19mm x 25.4mm] hinges from the 2" x 9" [50.5 x 228.5mm] hinge strip.

DO NOT GLUE YET.

Carefully cut hinge slots at the locations shown on the plan.

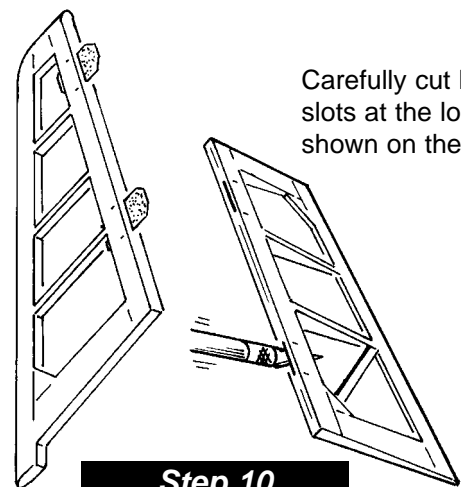

Step 10

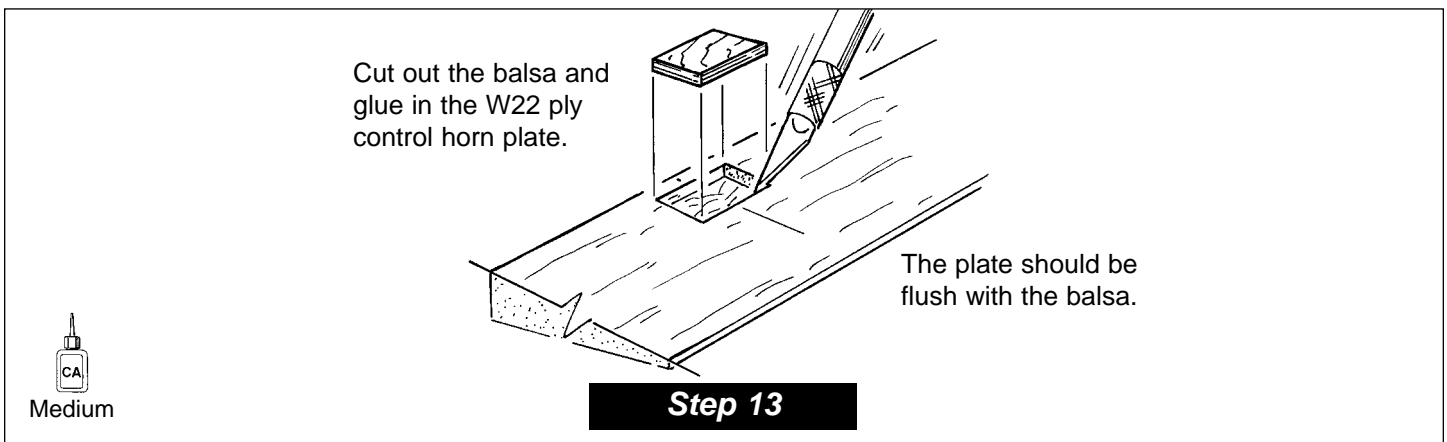
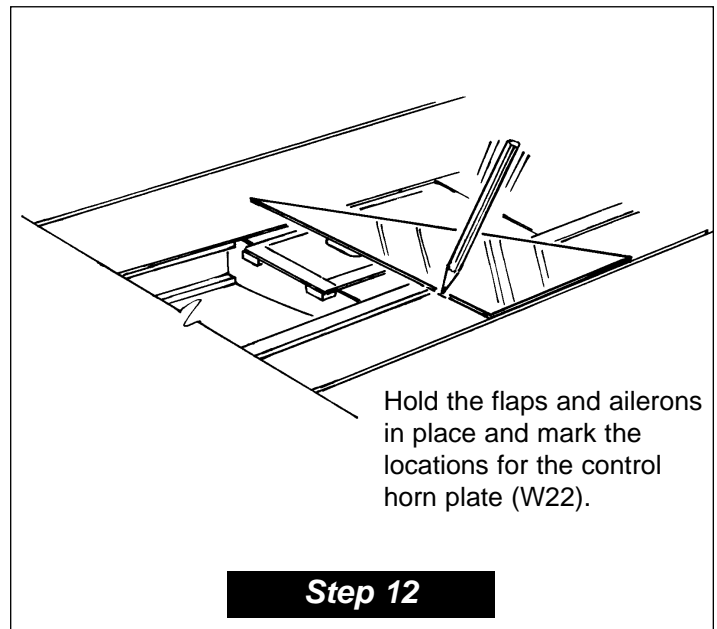
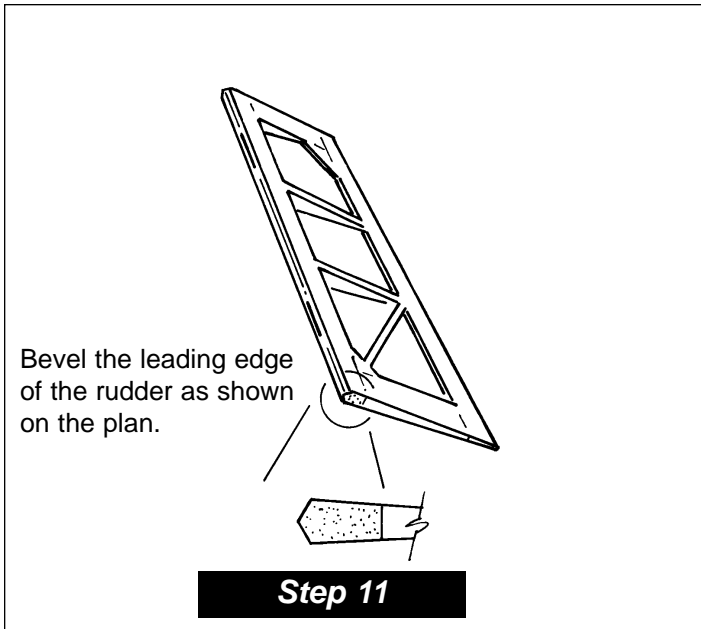

COVERING

Preparing The Surface

Most of the model should be rough-sanded by now, with all edges sanded and rounded following the cross-section views on the plans. If not, do so now. Fill all dents, seams, low spots and notches with HobbyLite™ balsa colored filler. After the filler has dried, use progressively finer grades of sandpaper to even and smooth all the edges, seams and surfaces. Remove all the balsa dust from the model with compressed air or a vacuum with a brush and a tack cloth.

Covering Technique

Cover the model with Top Flite MonoKote film, using the suggested covering sequence that follows.

Some modelers prefer to cover the top and bottom of the ailerons with one strip of MonoKote film. This is done by covering the bottom first, then wrapping the MonoKote film up over the leading edge.

Apply 1/4" wide strips of MonoKote film in the corners where the stab and fin meet the fuselage. Proceed to cover the stab with pre-cut pieces that meet in the corners and overlap the 1/4" strips. **Never cut the covering on the stab and fin** after it has been applied except around the leading and trailing edges and the tips. Modelers who do this may cut through the covering and into the wood. This will weaken the structure to a point where it may fail during flight.

SUGGESTED COVERING SEQUENCE

Fuselage and Tail:

1. 1/4" strips at stab as described above
2. Stab bottom
3. Stab Top
4. Fin Left and Right
5. Rudder Left and Right
6. Elevator bottom and top
7. Fuselage bottom
8. Fuselage left and right
9. Fuselage top

Wing:

1. Ailerons and Flaps bottoms and tops
2. Bottom right, followed by the bottom left wing panel. (If building the polyhedral wing, cover the inner and outer panels separately.
3. Top right, followed by the left wing panel.

Step 14

Installing CA Hinges for the Rudder

The Rudder in this kit is attached using two CA hinges where shown on the plans.

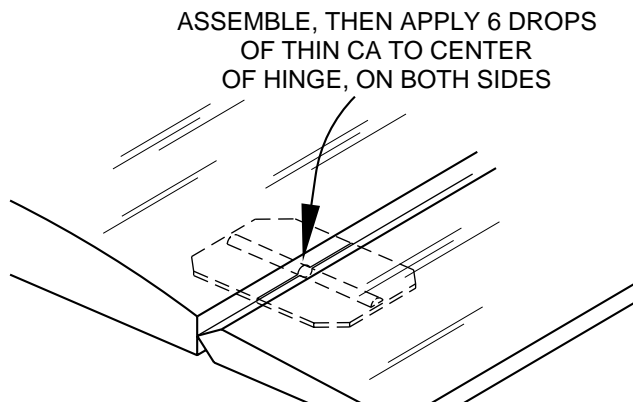
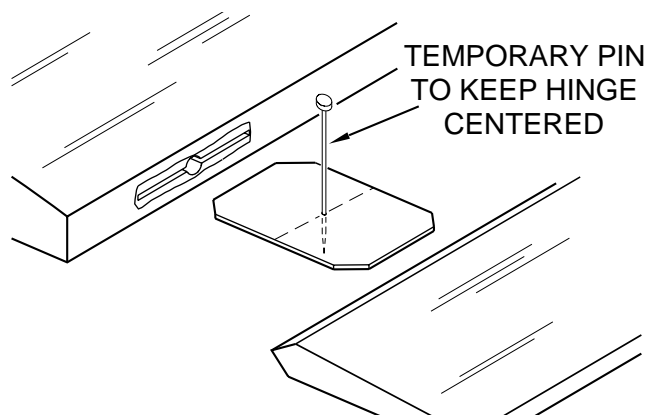
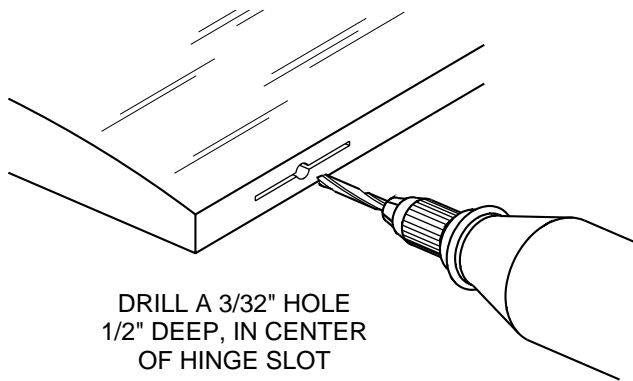

It is best to leave a very slight hinge gap, rather than closing it up tight. This will prevent the Glue from wicking along the hinge line. Insert a small pin through the center of each hinge to keep the hinge centered while you install the control surfaces.

Step 15

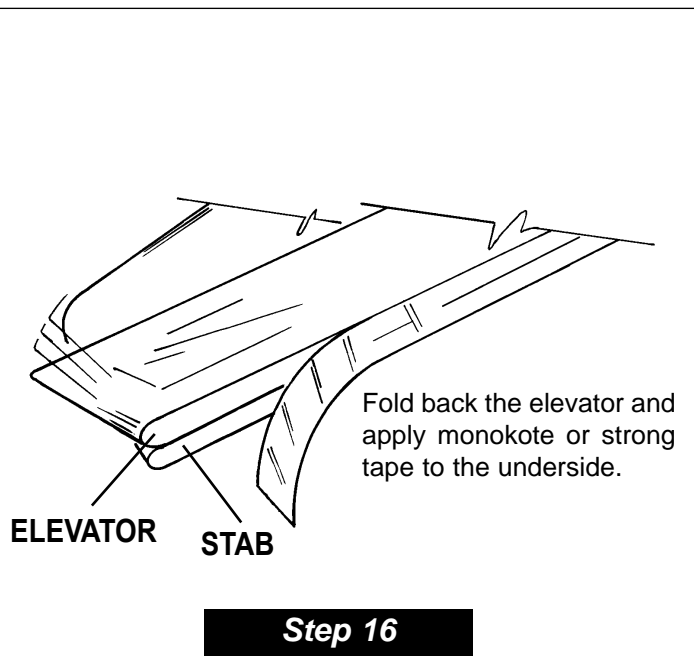

Align the stabilizer so that it is parallel with the wing.

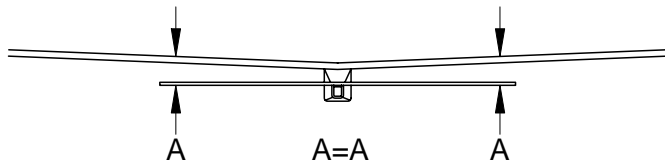

When satisfied with the fit, glue in place with epoxy.

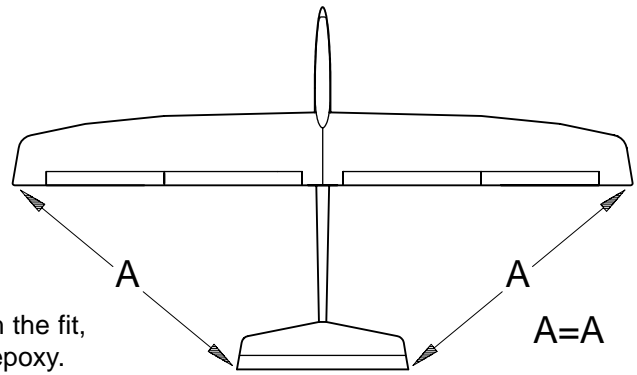

Step 18

Position the fin so it is straight with the fuselage. Remove the covering where the fin rests on the fuselage.

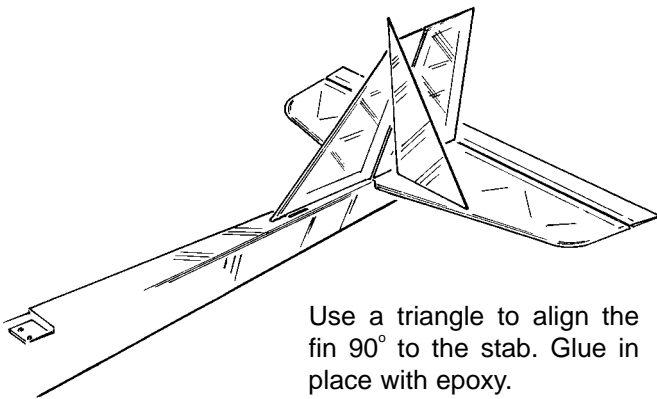

Use a triangle to align the fin 90° to the stab. Glue in place with epoxy.

Step 19

MONOKOTE OR STRONG TAPE HINGE

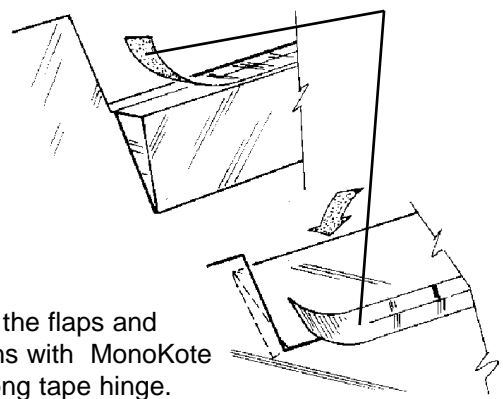

Install the flaps and ailerons with MonoKote or strong tape hinge.

Step 20

Cut servo blocks from the 3/16" x 3/8" x 2" [4.8mm x 9.5mm x 50.8mm] basswood.

Glue in place with Medium CA or epoxy.

Drill small pilot holes for the servo screws.

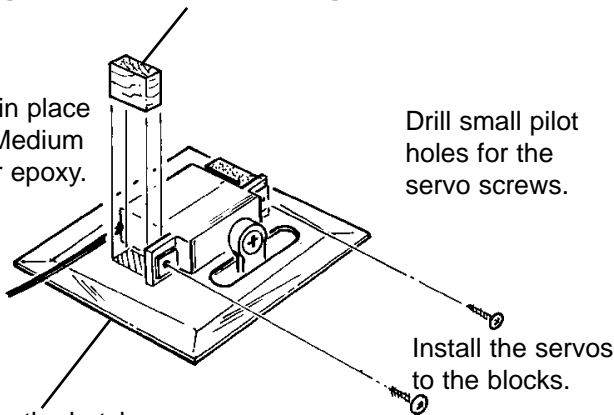

Install the servos to the blocks.

Cover the hatch with Monokote.

Step 21

2 X 3/8" [9.5mm] FLAT HEAD SCREWS

Drill pilot holes for the screws.

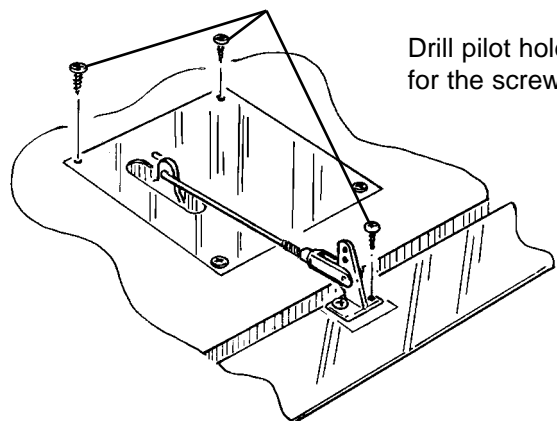

Step 22

Wrap the receiver and battery in foam.

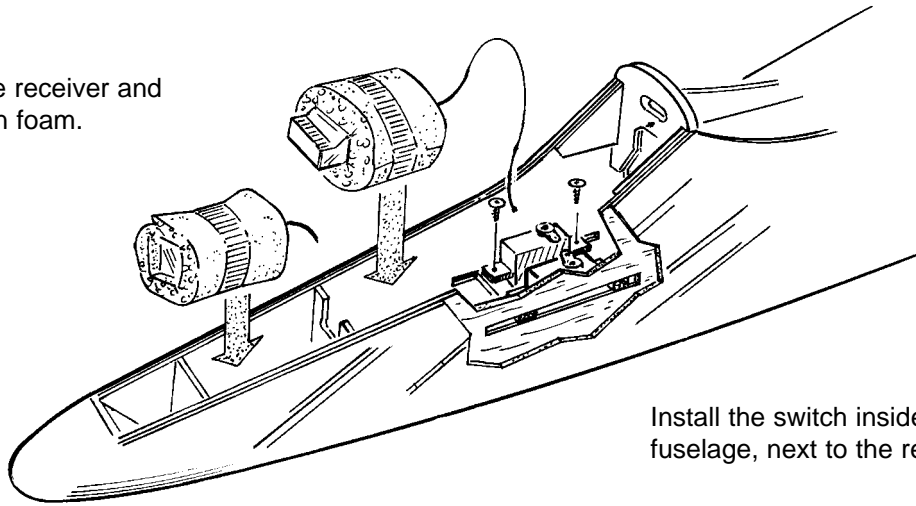

Install the switch inside the fuselage, next to the receiver.

Step 23

1" [25.4mm]
THREADED WIRE

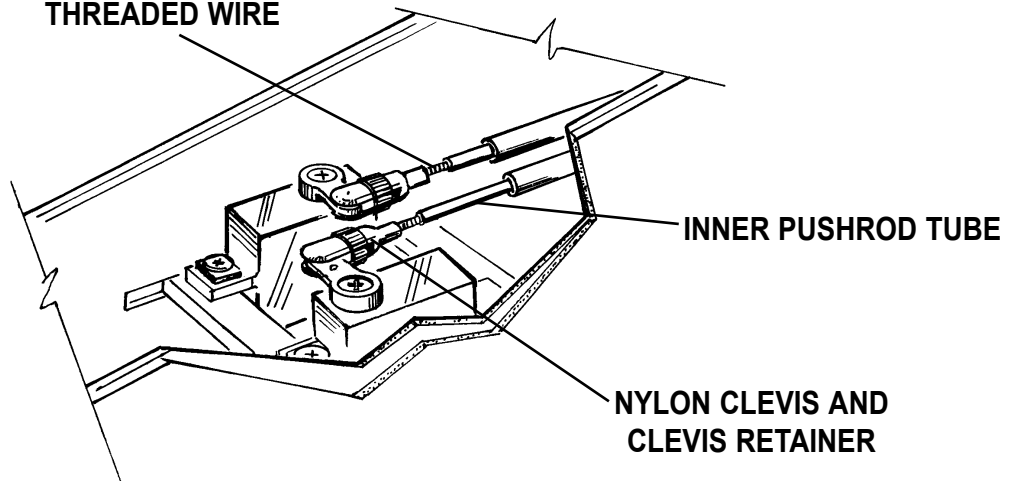

Step 24

METAL CLEVIS

1" [25.4mm]
THREADED WIRE

NYLON BACKPLATE

Line up the control horns with the pushrods. Attach the control horns to the elevator and rudder.

2-56 X 3/8" [9.5mm] BOLT

NYLON CONTROL HORN

2-56 X 3/8" [9.5mm] BOLT

Step 25

BALANCE THE MODEL

Balance at 3-1/4" (82mm)

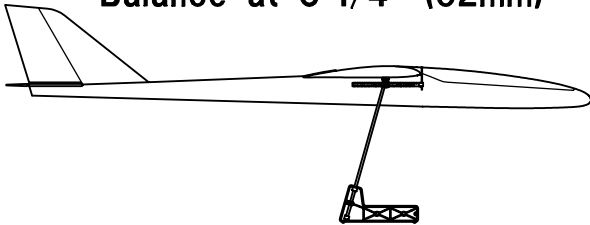

NOTE: This section is VERY important and must not be omitted! A model that is not properly balanced will be unstable and possibly unflyable.

1. The balance point (**Center of Gravity**) is **3-1/4" (82mm)** from the Leading edge. This is the balance point at which your model should balance for your first flights. Later, you may wish to shift the balance up to **1/2" (13mm) behind** this point to change the flying characteristics. Moving the CG forward will add stability but it will **decrease** the overall performance of the sailplane. Moving the balance back makes the model more agile with a lighter and snappier "feel" and **improves** the sailplane's response to air currents. However, it will also make the model **less stable** and can cause the sailplane to "tuck under" or dive when its flying speed increases.

2. With the wing attached to the fuse, and all parts of the model installed (ready to fly), lift the model by picking it up with your fingertips. If the tail drops when you lift, the model is "tail heavy" and you must add weight to the nose to balance. If the nose drops, it is "nose heavy" and you must add weight to the tail to balance. The model should hang with a slight nose down attitude. Add BB's or lead to the nose.

CONTROL SURFACE THROWS

Use these control throws for your first flights.

ELEVATOR: 1/2" (13mm)

RUDDER: 2" (50mm)

FLAPS: 1-3/8" (35mm) down

AILERONS: 3/4" (19mm) up, 3/8" (9.5mm) down

TOW HOOK LOCATION

1. The tow hook should be in the front hole for the first flights. After the first flights the tow hook can be moved back to the middle hole for most flying conditions. For contest flying you may want to try the rear hole as it can help achieve a higher launch. But be careful as the sailplane will be less stable and more apt to "Pop Off" the line.

FLYING

If you are not thoroughly familiar with the operation of R/C models, ask an experienced modeler to check to see you have the radio installed correctly and all the control surfaces do what they are supposed to.

TRIMMING FLIGHTS

It is a good idea to do a couple of trim flights before each flying session to make sure the plane is still in trim and the radio is working properly.



Hold the SPIRIT ELITE under the wing with the nose pointed slightly down and directly into the wind. Launch the model with the wings level and the nose pointing at a spot on the ground about 50 feet in front of you. If the sailplane is launched with the nose up or launched too hard it will climb a few feet, stall and fall nose first straight down. With the nose pointed down slightly the sailplane will accelerate down until it picks up enough flying speed, then level off and glide forward. Adjust the trims on your transmitter to get the plane to fly straight ahead in a smooth glide path.

HI-START LAUNCH

A hi-start is the most common way to launch your SPIRIT ELITE. Follow the directions that came with the hi-start and lay it out directly into the wind. Place the stake at the far upwind edge of the flying field so the parachute will blow back onto the flying field.

Hook the parachute up to the tow hook. Pull the plane back approximately twice as far as the rubber is long or whatever the hi-start instructions recommend.

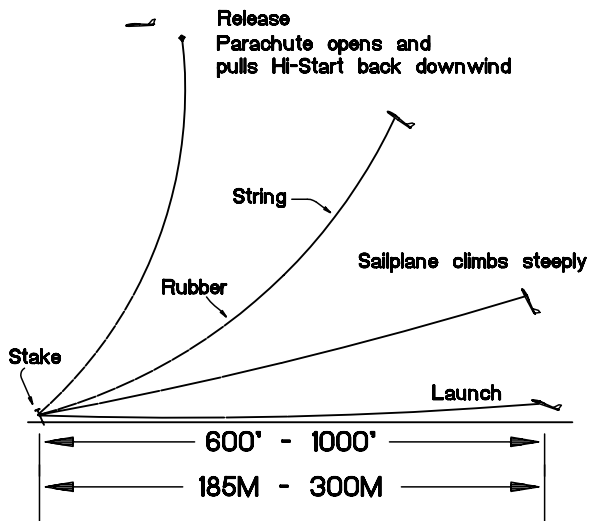

Hold the plane above your head with the wings level and the nose pointed slightly up and directly into the wind. Give the plane a push forward to get it flying and it will climb up like a kite. You should not have to touch the elevator during the launch. Use the **rudder stick** to keep it going straight up. You will find the ailerons are not very responsive during the first part of the launch. As the rubber relaxes the plane will fly off the hi-start.

FIRST FLIGHTS

Use these flights to get the "feel" of the controls and the SPIRIT ELITE'S flying characteristics. Adjust the trims on your transmitter (a little at a time) until the plane will fly straight and level with the transmitter sticks in their neutral positions. If you built the polyhedral wing, rudder alone is enough to perform smooth turns. If you built the straight wing, you will need to coordinate ailerons with rudder for smooth turns.

The SPIRIT ELITE is a very gentle plane that flies well in light to moderate winds. Practice coordinating ailerons and rudder until you can get a tight turn that is relatively flat. Bank the sailplane with rudder and ailerons first, then add elevator to pull it around. When setting up to land, point the nose into the wind just downwind of where you want to land. Line up with your landing spot and slowly feed in flaps (or Crow). Add more or less flaps to control your descent angle and speed so you end up hitting the spot.

ADVANCED FEATURES

There are several types of mixing the Spirit Elite can take advantage of if you have a "computer radio".

Launch Camber: Lowering the flaps and ailerons during the launch will produce a steeper climb giving you better altitude. A good place to start is about 15 degrees of flap and 5 degrees of aileron drop (The flaps will drop about three times more than the ailerons). This automatically puts some washout in the wing which adds stability for arrow straight launches. If you don't have a switch for launch camber, just use the flaps for launch.

Crow: This is used to lose altitude quickly and to control your glide for spot landings. This mixing is tied to the flap stick (throttle) and allows the ailerons to come up as the flaps drop. Be sure to use plenty of aileron differential when using CROW mixing because the ailerons become less effective at very high angles of deflection. Also use maximum rudder coupling at full CROW. If you don't have CROW capabilities just use flaps and make sure you have full rudder throw when the flaps start coming down. It is a good idea to **get lined up on the spot** before dropping the flaps very much because the rudder will become sluggish with the flaps down at slow speeds. Note: You will need to mix in a little down elevator with the flaps to keep the plane tracking straight.

Aileron/Rudder Coupling - This is used to allow the sailplane to make efficient, non-slipping, non-skidding turns. You will need to experiment to find the proper amount of throw required to do this but 1" (25mm) of rudder throw at full aileron is probably a good place to start.

Elevator/Camber Coupling - This is a neat type of mixing allows the TE (ailerons and flaps) to respond to the elevator. When properly set up, this can be very useful when floating around in light air or when trying to thermal very tightly. This mixing can change the flying characteristics of the plane so start off small and get used to it. A good place to start would be 1/8" (3mm) of TE drop at full up elevator.

Controlling the Wing Trailing Edge (Camber): The wing camber is usually controlled by a 3-position switch. The traditional way of setting this switch is to have: the middle position set to neutral camber, one direction for reflex (the entire TE raises about 1/16" (1.5mm)) and the other direction for positive camber (the entire TE drops about 3/32" (2.5mm)). This way of programming the switch is great for good thermal-days or days with a lot of wind where you might need the reflex capability for zooming up wind. The other way we set this switch is to have the "back" position for neutral camber, the middle position for a slight amount of positive camber (1/32" (1mm) - 1/16" (2mm)), and the forward position for more positive camber (3/32" (2.5mm) - 1/8" (3mm)). The middle position can be used once good air is located or when trying to gain a few extra seconds of air time. Normally the L/D will not be as great as neutral camber but the sailplane will float better. The forward position is when the sailplane is low and encounters lift, don't panic, just hit the switch. The SPIRIT ELITE will really slow up and will thermal "on a dime". This set-up is great for duration type flying without a lot of wind.

FACTS ABOUT THERMALS

Thermals are a natural phenomenon that happen outside, by the millions, every single day of the year. Thermals are responsible for many things including forming several types of clouds, creating breezes, and distributing plant seeds and pollen. If you have ever seen a dust devil (which is nothing more than a thermal that has picked up dust), you have seen a thermal in action. Their swirling action is very similar to that of a tornado but much gentler. Most thermals have updrafts rising 200-700 feet per minute but have been known to produce updrafts of over 5,000 feet per minute. These strong thermals can rip a plane apart or carry the plane out of sight before the pilot can get out of the updraft.

TYPICAL THERMAL

Wind causes thermal to drift downwind

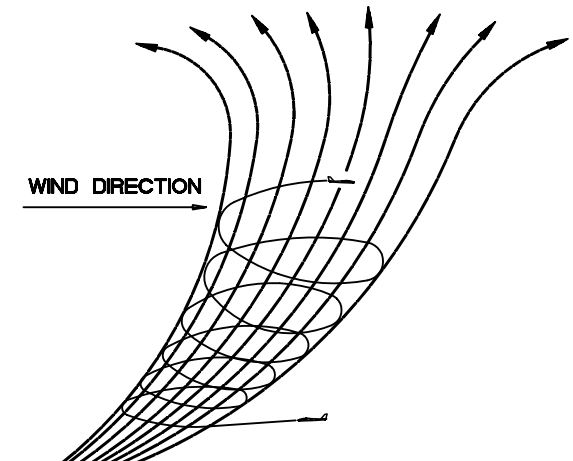

Thermals are formed by the uneven heating of the earth and buildings, etc. by the sun. The darker colored surfaces absorb heat faster than the lighter colors which reflect a great deal of the sun's energy back into space. These darker areas (plowed fields, asphalt parking lots, tar roofs, etc.) get warmer than the lighter areas (lakes, grassy fields, forests, etc.). This causes the air above the darker areas to be warmer than the air over the lighter areas and the more buoyant warm air rises as the cooler, denser air forces its way underneath the warmer air. As this warm air is forced upward it contacts the cooler air of the higher altitudes and this larger temperature difference makes the thermal rise quicker. The thermal is gradually cooled by the surrounding cooler air and its strength diminishes. Eventually the thermal stops rising and any moisture contained in the once warm air condenses and forms a puffy cumulus cloud. These clouds, which mark the tops of thermals, are usually between 2000 and 5000 feet high.

THERMAL SOARING

As the glider approaches a thermal, the wing tip that reaches the rising air first will be lifted before the opposite wing tip. This causes the plane to "bank" and turn away from where we would like the plane to go. The best way to get back in is to continue the bank and turn 270 degrees straight into the thermal.

When you are thermal soaring, try to fly as smoothly and straight as possible. Trim the plane to fly in a straight line and **only** touch the controls when you have to. Watch the sailplane carefully and it will tell you what it is encountering.

When the sailplane flies directly into a thermal it will either start rising or stop sinking. Either case is reason enough to start circling. Fly straight until you feel like you are in the strongest lift, then fly a **couple of seconds farther** so your circle will be centered in the strongest lift. Thermals travel with the wind, so be careful that you don't get too far downwind that you can't get back. If you find yourself getting too high, don't dive the plane to get out of the lift. Sailplanes are very efficient aircraft and they will build up a lot of speed and could "blow up" in the rough air of a thermal. The easiest way to lose altitude is to apply full rudder and full up elevator. This will put the plane into a tight spin that will not over stress the airframe but it will enable it to lose altitude very quickly. This is especially helpful if the sailplane gets sucked into a cloud or it gets too high to see.

As you might expect, with all this air rising, there is also air sinking. This air is the sailplane pilot's nightmare that can really make soaring challenging. "Sink" is **usually** not as strong as the thermals in the same area but sometimes can be. Because of this, it is important you do not let the sailplane get too far downwind.

Watch the birds! - Thermals suck up small insects many birds love to eat. A bunch of swallows flying around in one area may indicate a thermal. Soaring birds (hawks, vultures, eagles etc.) are the best thermal indicators. They not only show you where the thermal is but they also show you where the center is. These "Masters of the sky" will often fly right along with sailplanes.

Practice those landings! - Most thermal contests are won or lost during the landing. Establish a particular landing pattern and try to stick to it for all landings. Learn to shift your pattern to account for the wind and particular flying field characteristics. Flaps can be very useful during contest landings. They allow you to bring the sailplane in for a landing higher or faster than normal to guard against any last minute sink or gusts and dump the extra altitude and speed at the last second. They can also be used to help

control your skid. Flaps will stop the plane from sliding a little quicker. You can also “steer” the plane while it is sliding along the ground. Don’t expect to be able to “horse it around” but you can gain valuable inches by using the rudder to guide it towards the spot as it slides to a stop. Be very careful not to “ground loop” the plane since you will lose your landing points if the plane flips over.

have a **lot** of thermal activity. Center the weight directly on the center of gravity of the plane so you can add ballast without having to re-balance the plane. When learning to ballast your plane, start out small and work your way up.

Have fun and Good lift!!

SLOPE SOARING

To be able to slope soar, you need a slope with a smooth piece of land (or water) out in front of it and a breeze blowing pretty close to straight up the slope. The higher and steeper the hill or cliff the better. Also the larger and smoother the land out in front the better. The air flowing towards the hill, is forced up and can generate a very large area of lift. Behind the hill is a large area of turbulent air that can be very dangerous to try to fly in. The faster the wind is blowing the stronger the lift and turbulence will be.

To fly off a slope, stand near the edge and throw the sailplane (nose down) into the wind. As the sailplane flies out into the “band” of lift it will begin to gain altitude. Turn and fly parallel to the slope and make all of your turns into the wind (especially when you are close to the slope). You will be surprised at the altitude you can gain just from slope lift. Thermals will often be “popped loose” by these slopes. If you catch a thermal and follow it downwind, be very careful to stay high enough to make it back to the slope without flying through the turbulent air. Landings can be very tricky on some slopes. On gentle slopes you can often fly very close to the top of the slope and “slide” into the top of the slope without encountering any turbulent air. On steeper slopes you may have to be a little more aggressive to get the plane out of the lift. In any case it is a good idea to plan your landing before you launch your plane.

BALLAST

In strong wind conditions, you may want to add ballast (weight) to the sailplane to increase its wing loading which increases its normal flying speed. Increasing the weight of your sailplane does not change its “glide ratio” but it does make it **fly** faster which makes it sink a proportional amount faster. Because of this faster sink rate, you need to be very cautious when ballasting for a thermal contest. In duration type contests only use ballast on very windy days that also

Perfect choices for every sailplane pilot.



Their quiet flight keeps your airfield's neighbors happy. Getting into action is clean, quick and easy. And the best reason of all to fly a Great Planes sailplane? Their performance is awesome—right out of the box!

Extend your airtime indefinitely with a Great Planes sailplane...there's always more as close as the next thermal! Like the Spirit Elite, the Spirit 100 and Spectra both offer fast, easy assembly, made even more enjoyable by Great Planes' perfectly interlocking wood parts, photo-illustrated instruction manuals and premium quality hardware. Both include canopy and molded cockpit.



Spectra™ Electric Sailplane

Electric motor power and a 78.5" span, triple-taper wing with modified Selig 3010 airfoil give the Spectra outstanding climbing ability...while the model's clean, aerodynamic design helps you stretch your soaring times by moving easily from thermal to thermal. The kit's easy assembly (using the photo-illustrated manual), durability and forgiving flight make it great for beginners. Includes hardware, canopy, molded cockpit, Goldfire 550 motor system and 8x4 prop. Add Great Planes' scimitar style 8x4 Nylon Folding Propeller (GPMQ1690) to minimize drag.

- **A 2-meter electric that climbs from 0-500 feet in 60 seconds!**
- **Suitable for any skill level, with easy kit assembly, smooth flight characteristics and a durable airframe.**
- **Powered by an included Goldfire 550 motor system.**

GPMA0540

Wingspan: 78.5 in (1995mm)

Wing Area: 676 sq in (43.6 sq dm)

Weight: 48-52 oz (1360-1470g)

Wing Loading: 10 oz/sq ft (31 g/sq dm)

Fuselage Length: 38 in (965mm)

Requires: 2-3 channel radio, 6-7 cell battery & charger



Spirit™ 100.

Keep your costs in check and still enjoy high-performance features with the Great Planes Spirit 100. Interlocking construction makes it beginner-easy to build. Two wing options—the proven Spirit wing with S-3010 airfoil, or an advanced version with a highly efficient S-7037 airfoil, plus flaps and ailerons for greater control—enable fliers of all skill levels to enjoy its versatile performance. The advanced wing enables experienced sailplane pilots to use crow mixing and offers complete camber-changing capability for superior thermalling!

- **Huge 100" wingspan for extra-smooth flight!**
- **Two wing options in one easy-to-build kit.**
- **High performance without high cost.**

GPMA0550

Wingspan: 100 in (2530mm)

Wing Area: 946 sq in (61 sq dm)

Weight: 3-4 lb (1420-1840g)

Wing Loading: 8-10 oz/sq ft (23-31 g/sq dm)

Fuselage Length: 51.5 in (1310mm)

Requires: 2-4 channel radio with 2-5 servos (use 3-channel

