

Slow Poke™

INSTRUCTION MANUAL



WARRANTY

Great Planes Model Manufacturing Co. guarantees this kit to be free from defects in both material and workmanship at the date of purchase. This warranty does not cover any component parts damaged by use or modification. **In no case shall Great Planes' liability exceed the original cost of the purchased kit.** Further, Great Planes reserves the right to change or modify this warranty without notice.

In that Great Planes has no control over the final assembly or material used for final assembly, no liability shall be assumed nor accepted for any damage resulting from the use by the user of the final user-assembled product. By the act of using the user-assembled product, the user accepts all resulting liability.

If the buyers are not prepared to accept the liability associated with the use of this product, they are advised to return this kit immediately in new and unused condition to the place of purchase.

READ THROUGH THIS INSTRUCTION MANUAL FIRST. IT CONTAINS IMPORTANT INSTRUCTIONS AND WARNINGS CONCERNING THE ASSEMBLY AND USE OF THIS MODEL.



P.O. Box 788 Urbana, IL 61801 (217) 398-8970
productsupport@greatplanes.com

TABLE OF CONTENTS

SAFETY PRECAUTIONS	2
INTRODUCTION	3
DECISIONS YOU MUST MAKE	3
Engine selection	3
PREPARATIONS	3
Required accessories	3
Building supplies and tools	3
Optional supplies and tools	4
Building notes	4
Common abbreviations	5
Types of wood	5
Get ready to build	5
Metric conversion chart	5
DIE-CUT PATTERNS	6
BUILD THE TAIL SURFACES	7
Build the stab	7
Build the elevators	7
Build the fin	8
Build the rudder	8
Hinge the tail surfaces	9
Finish the tail surfaces	9
BUILD THE WING	9
Build the wing center section	9
Build the outer wing panels	13
Finish the wing	16
BUILD THE FUSELAGE	17
Assemble the fuselage formers and sides	17
Mount the wing	19
Mount the engine	20
Mount the tail	21
Build the front deck and turtle deck	23
Install the servos and make the pushrods	25
PREPARE FOR COVERING	26
COVER THE MODEL WITH MONOKOTE FILM	26
FUELPROOF THE MODEL	26
INSTALL THE WINDSHIELD	26
INSTALL THE TANK	27
INSTALL THE LANDING GEAR	27
FINAL HOOKUPS AND CHECKS	27
Attach the control surfaces	27
Install the hardware	28
Final servo and receiver installation	28
Set the control throws	28
BALANCE YOUR MODEL	28
Balance the model laterally	28
Balance the model fore & aft (CG)	29
PREFLIGHT	29
Charge the batteries	29
Balance the propeller	29
Find a safe place to fly	29
Ground check the model	30
Range check your radio	30
Engine safety precautions	30
AMA safety code	30

FLYING	31
Takeoff	31
Flight	31
Landing	31
TWO VIEW DRAWING	back cover

PROTECT YOUR MODEL, YOURSELF & OTHERS...FOLLOW THIS IMPORTANT SAFETY PRECAUTION

Your SlowPoke is not a toy, but rather a sophisticated, working model that functions very much like an actual airplane. Because of its realistic performance, the SlowPoke, if not assembled and operated correctly, could possibly cause injury to yourself or spectators and damage property.

If this is your first low wing model we recommend that you get help from an experienced, knowledgeable modeler with your first flights. You'll learn faster and avoid risking your model before you're truly ready to fly it solo. Your local hobby shop has information about flying clubs in your area whose membership includes qualified instructors. You may also contact the national Academy of Model Aeronautics (AMA), which has more than 2,500 chartered clubs across the country. Contact the AMA at the address or toll-free phone number below.



Academy of Model Aeronautics

5151 East Memorial Drive
Muncie, IN 47302-9252
Tele. (800) 435-9262
Fax (765) 741-0057

or via the Internet at <http://www.modelaircraft.org>

PRECAUTIONS

1. Build the plane according to the plans and instructions. Do not alter or modify the model, as doing so may result in an unsafe or unflyable model. In a few cases the plans and instructions may differ slightly from the photos. In those instances the plans and written instructions are correct.
2. Take time to build straight, true and strong.
3. Use an R/C radio system that is in first-class condition, and a correctly-sized engine and components (fuel tank, wheels, etc.) throughout your building process.
4. You must properly install all components so that the model operates properly on the ground and in the air.

5. You must check the operation of the model before **every** flight to ensure that all equipment is operating and that the model has remained structurally sound. Be sure to check nylon clevises or other connectors often and replace them if they show signs of wear or fatigue.

6. If you are not already an experienced R/C pilot you must fly the model only with the help of a competent, well experienced R/C pilot.

NOTE: We, as the kit manufacturer, provide you with a top quality kit and great instructions, but ultimately the quality of your finished model depends on how **you** build it; therefore, we cannot in any way guarantee the performance of your completed model, and no representations are expressed or implied as to the performance or safety of your completed model.

Remember: Take your time and follow directions to end up with a well-built model that is straight and true.

Please inspect all parts carefully before starting to build! If any parts are missing, broken or defective, or if you have any questions about building or flying this airplane, please call us at (217) 398-8970 or e-mail us at productsupport@greatplanes.com. If you are calling for replacement parts, please reference the part numbers and the kit identification number (stamped on the end of the carton) and have them ready when calling.

INTRODUCTION

Congratulations and thank you for purchasing the Great Planes SlowPoke. The SlowPoke is perfectly suited for small field flying and because of its size is easy to transport. Great Planes has taken a simplified approach to the SlowPoke's design by incorporating a CAD designed airframe with the "stick style" construction of yesteryear.

The SlowPoke was intentionally designed for easy 3-channel flying, a small displacement engine and a light wing loading. When finished, the SlowPoke is quite capable of slow, leisurely flight without the worry. Its styling is reminiscent of the Golden Age of aviation and very pleasing.

DECISIONS YOU MUST MAKE

Engine Selection

There are several engines that will work well in the SlowPoke, but for maximum performance we recommend an O.S.® .15 LA or .20 FP™ or if you prefer a 4-stroke, an O.S. .26 Surpass works well.

PREPARATIONS

Required Accessories

*Items in parentheses (OSMG2691) are suggested part numbers recognized by distributors and hobby shops and are listed for your ordering convenience. **GPM** is the Great Planes® brand, **TOP** is the Top Flite® brand, and **HCA** is the Hobbico® brand.*

- 4 Channel Radio with 3 Servos
- Engine; See **Engine Selection**
- Spare Glow Plugs
 - (O.S.® #8 for most 2-stroke engines, OSMG2691)
 - (O.S.® Type-F for most 4-stroke engines, OSMG2629)
- Propeller (Top Flite Power Point®) *Refer to your engine's instructions for proper size*
- Top Flite Super MonoKote® covering (Approximately 2 rolls); See **Covering** (page 26)
- Fuel-Proof paint; See **Fuelproofing** (page 26)
- 12" Medium Fuel Tubing (GPMQ4131, 3')
- 1/4" Latex Foam Rubber Padding (HCAQ1000)
- 4 oz. Fuel Tank (GPMQ4101)
- (2) 3" Lightweight Wheels (DAVQ5030)
- (4) 5/32" Wheel Collars (GPMQ4306)
- (1) 3/32" Wheel Collar (GPMQ4303)
- 1-1/2" Spinner (GPMQ4500 – white)
- Pilot (WBRQ2475) Scale Sportsman Pilot used in prototype.
- (1) 1-1/4" Tail Wheel (GPMQ4242)

Building Supplies and Tools

These are the building tools, glue, etc. that we recommend and mention in the manual.

- 1 oz. Thin Pro™ CA (GPMR6002)
- 1 oz. Medium Pro™ CA+ (GPMR6008)
- 1 oz. Thick Pro™ CA- (GPMR6014)
- Pro CA Accelerator (GPMR6035)
- 6-Minute Pro™ Epoxy (GPMR6045)
- 30-Minute Pro™ Epoxy (GPMR6047)
- Pacer Formula 560 Canopy Glue (PAAR3300)
- #1 Hobby Knife Handle (HCAR0105)
- #11 Blades (HCAR0311, 100 Qty.)
- X-Acto® Razor Saw (XACR2531)
- Hobbico Builder's Triangle Set (HCAR0480)
- Small T-pins (HCAR5100)
- Medium T-pins (HCAR5150)
- Great Planes Plan Protector™ (GPMR6167)
- Chalk
- Masking Tape
- 10-32 Tap and Drill set (GPMR8104, drill bit included)

- Electric Power Drill
- Drill Bits: 1/16", 1/8", 3/16", 5/32", 13/64", 9/64", 1/4"
- Monofilament line for aligning wing and stabilizer
- Screwdrivers (Phillips and Flat Blade)
- HobbyLite™ Balsa Filler (HCAR3401)
- Sealing Iron (TOPR2100)
- Bar Sander or Sanding Block and Sandpaper (coarse, medium, fine grit)



Made of durable, lightweight aluminum, Easy-Touch™ Sanders have a uniquely contoured handle that lets you work longer with less fatigue! The incredibly flat sanding surface removes high spots with ease. The 5.5" Hand Sander is ideal for small parts and tight spaces. Use the 11" - 44" Bar Sanders for larger areas. Take the guesswork out of sanding curved or angled shapes with the Easy-Touch Multi-Sander. Available in 11" and 22" lengths. Easy-Touch adhesive-backed sandpaper is already trimmed to these tools' width...just cut it to length and press in place. Available in 4 different grits.



- | | |
|---------------------------|-----------------------------|
| GPMR6169 Hand Sander-5.5" | GPMR6170 Bar Sander-11" |
| GPMR6172 Bar Sander-22" | GPMR6174 Bar Sander-33" |
| GPMR6176 Bar Sander-44" | |
| GPMR6190 Multi-Sander-11" | GPMR6191 Multi-Sander-22" |
| GPMR6180 | 80-Grit Sandpaper-12' roll |
| GPMR6183 | 150-Grit Sandpaper-12' roll |
| GPMR6184 | 180-Grit Sandpaper-12' roll |
| GPMR6185 | 220-Grit Sandpaper-12' roll |

Optional Supplies and Tools

- CG Machine™ (GPMR2400)
- AccuThrow® Deflection Meter (GPMR2405)
- Great Planes Dead Center™ Engine Mount Hole Locator (GPMP8130)
- CA Applicator Tips (HCAR3780)
- Epoxy Brushes (GPMR8060)
- Epoxy Mixing Sticks (GPMR8055, Qty. 50)
- CA Debonder (GPMR6039)
- Clevis Installation Tool (GPMR8030)
- Hot Sock™ (TOPR2175)
- Trim Seal Tool (TOPR2200)
- Heat Gun (TOPR2000)
- Single Edge Razor Blades (HCAR0312, 100 Qty.)

- Razor Plane (MASR1510)
- 36" Non-Slip Straightedge (HCAR0475)
- Denatured or Isopropyl Alcohol (for epoxy clean-up)
- Dremel® Moto-Tool™ or similar w/Sanding Drum, Cutting Burr, Cut-off Wheel
- Curved-Tip Canopy Scissors (HCAR0667)
- Servo Horn Drill (HCAR0698)
- Top Flite Precision Magnetic Prop Balancer™ (TOPQ5700)
- Great Planes Fingertip Balancer (GPMQ5000)

Building Notes

There are two types of screws used in this kit:

Sheet metal screws are designated by a number and a length.

For example #6 x 3/4"



Machine screws are designated by a number, threads per inch and a length.

For example 4-40 x 3/4"



When you see the term **“test fit”** in the instructions, it means you should first position the part on the assembly **without using any glue**, then slightly modify or “custom fit” the part as necessary for the best fit. Do **not** glue until told to do so.

When you see the term **“fit and glue”** in the instructions, it means you should first position the part on the assembly **without using any glue**, then modify or “custom fit” the part as necessary for the best fit. Glue when you are satisfied with the fit.

Whenever just **“epoxy”** is specified you may use **either** 30-minute epoxy **or** 6-minute epoxy. When 30-minute epoxy is **specified** it is **highly recommended** that you use only 30-minute epoxy because you will need the working time and/or the additional strength.

Where you see the term **“glue”**, it is at your option to select the thickness of CA with which you are most comfortable. If the step indicates a particular thickness of glue, be sure to use the thickness recommended for strength, penetration and/or working time.

Several times during construction we refer to the “top” or “bottom” of the model or a part of the model. For example, during construction we tell you to “glue the top main spar” or “trim the bottom of the former.” It is understood that the “top” or “bottom” of the model is as it would be when the airplane is right-side-up and will be referred to as the “top” even if the model is being worked on upside-down. I.E. the “top” is always the “top”, even when the fuse is being built upside-down.

Common Abbreviations

Elev = Elevator	Fuse = Fuselage
LE = Leading Edge (front)	LG = Landing Gear
Lt = Left	Ply = Plywood
Rt = Right	Stab = Stabilizer
TE = Trailing Edge (rear)	" = Inches

Types of Wood

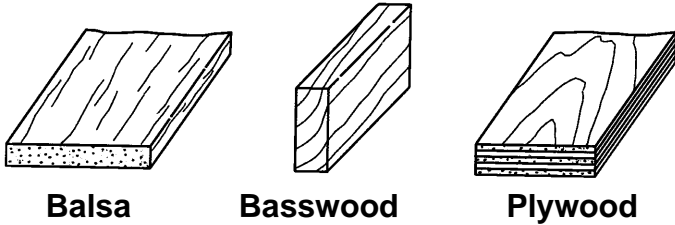

Balsa

Basswood

Plywood

Get Ready to Build

1. Unroll the plan sheets. Reroll the plan sheets inside out to make them lie flat.
2. Remove all parts from the box. As you do, determine the name of each part by comparing it with the plan and the parts list included with this kit. Using a felt-tip or ballpoint pen, lightly write the part **name** or **size** on each piece to avoid confusion later. Use the die-cut patterns shown on page 6 to identify the die-cut parts and mark them **before** removing them from the sheet. **Save all leftovers.** If any of the die-cut parts are difficult to punch out, do not force them! Instead, cut around the parts with a hobby knife. After punching out the die-cut parts, use your bar sander or sanding block to **lightly** sand the edges to remove any die-cutting irregularities or slivers.
3. As you identify and mark the parts, separate them into groups, such as **fuse** (fuselage), **wing**, **fin**, **stab** (stabilizer) and **hardware**.



Zipper-top food storage bags are handy to store the small parts as you sort, identify and separate them into sub-assemblies.

Metric Conversion Chart

1" = 25.4mm (conversion factor)

1/64" = .4mm	1" = 25.4mm
1/32" = .8mm	2" = 50.8mm
1/16" = 1.6mm	3" = 76.2mm
3/32" = 2.4mm	6" = 152.4mm
1/8" = 3.2mm	12" = 304.8mm
5/32" = 4mm	15" = 381mm
3/16" = 4.8mm	18" = 457.2mm
1/4" = 6.4mm	21" = 533.4mm
3/8" = 9.5mm	24" = 609.6mm
1/2" = 12.7mm	30" = 762mm
5/8" = 15.9mm	36" = 914.4mm
3/4" = 19mm	

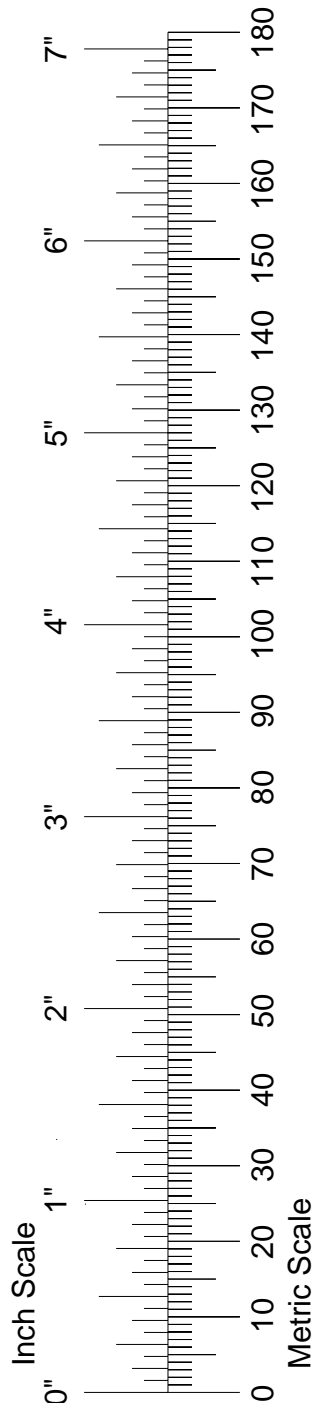

DIE-CUT PATTERNS

1/8" X 4-5/8" X 23-3/4" PLY

1 PER KIT

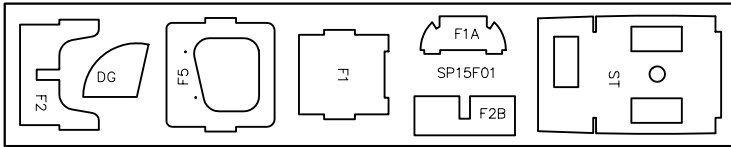

SP15F01

3/16" X 3" X 15" BALSA

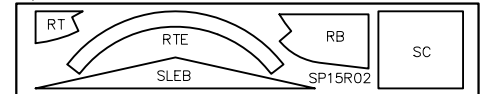

SP15R02

1 PER KIT

3/16" X 3" X 15" BALSA

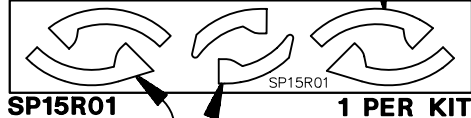

SP15R01

1 PER KIT

Elevator Tip (Inboard)

Stab Tip

Elevator Tip (Outboard)

1/16" x 4" x 24" BALSA

2 PER KIT

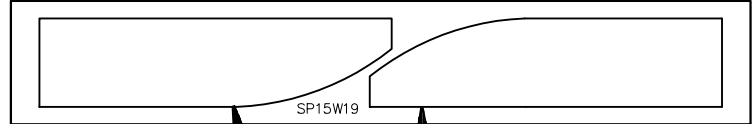

SP15W19

TE Tip Sheeting

Bottom Engine Mount

1/8" X 4" X 24" BALSA

2 PER KIT

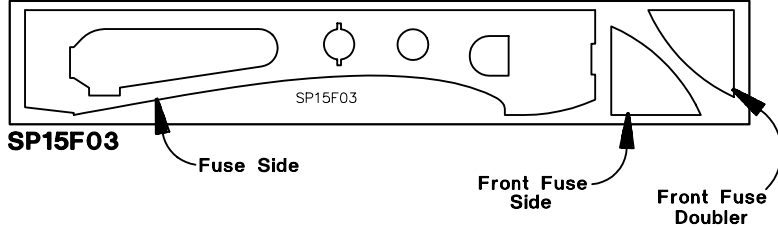

SP15F03

Fuse Side

Front Fuse Side

Front Fuse Doubler

1/8" X 3-1/4" X 15-3/4" PLY

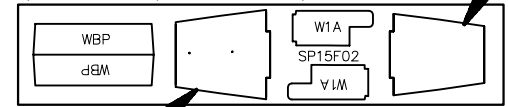

SP15F02

Top Engine Mount

1 PER KIT

1/16" x 3" x 24" BALSA

2 PER KIT

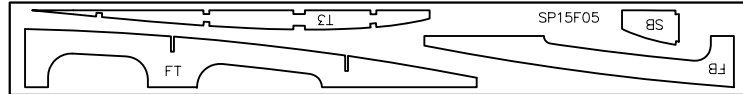

SP15F05

1/8" X 4" X 18" BALSA

2 PER KIT

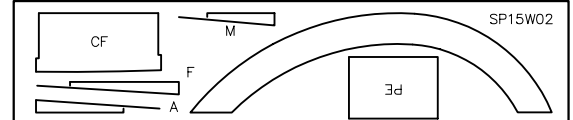

SP15W02

1/8" X 4" X 24" BALSA

1 PER KIT

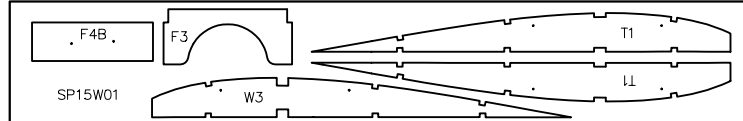

SP15W01

1/8" X 3" X 15" BALSA

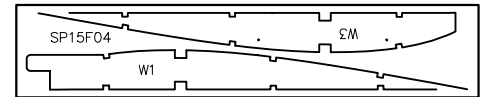

SP15F04

1 PER KIT

1/32" X 4-1/8" X 19" BIRCH PLY

Forward Fuse Doubler

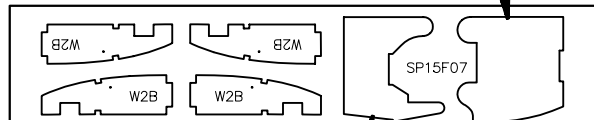

SP15F07

2 PER KIT

Aft Fuse Doubler

3/32" X 4" X 18 BALS

1 PER KIT

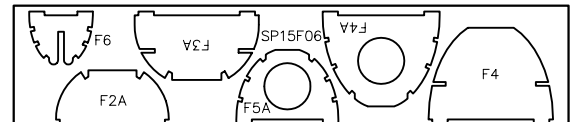

SP15F06

1/16" x 3" x 24" BALS

2 PER KIT

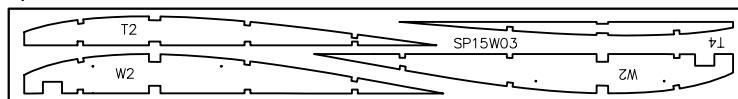

SP15W03

BUILD THE TAIL SURFACES

You may remove the stabilizer and elevator drawing from the plan by cutting along the dashed line. Don't forget to cover the plan with Great Planes Plan Protector™ so the glue won't stick to the plan.

Build the Stab

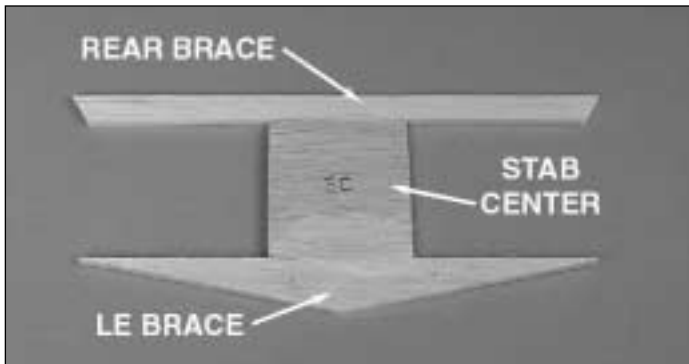

- 1. Pin the die-cut 3/16" balsa **stab LE brace** in position over the plan. Glue the die-cut 3/16" balsa **stab center** to the stab LE brace.

Note: Refrain from using excessive accelerator. Even hours after it's sprayed on, residual accelerator can prematurely and unexpectedly cure the CA you use later on nearby glue joints. Unless you must handle or remove the part from the building board right away, we recommend using no accelerator at all.

- 2. From a 3/16" x 1/2" x 24" balsa stick, fit and glue the **rear brace** in place. **Note:** Save all the remaining pieces of the sticks that you cut.

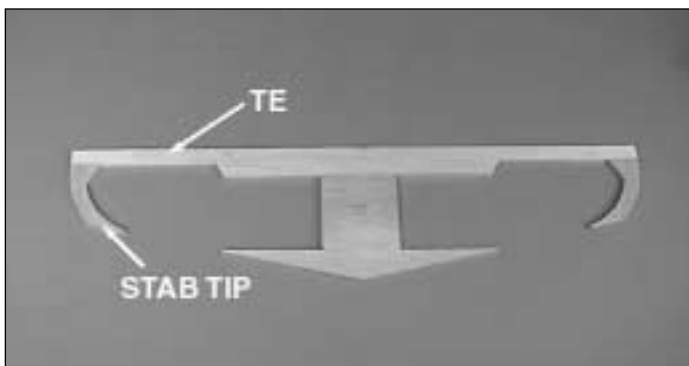

- 3. From a 3/16" x 1/2" x 24" balsa stick, fit and glue the **trailing edge** to the rear brace.
- 4. Glue the die-cut 3/16" balsa **stab tips** to the trailing edge.

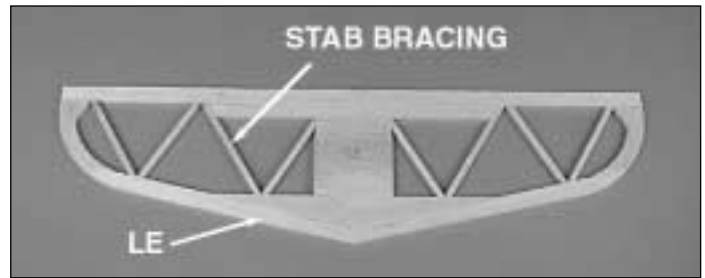

- 5. From a 3/16" x 1/2" x 24" balsa stick, fit and glue the two **leading edges** in place.
- 6. From two 3/16" x 3/16" x 24" balsa sticks, fit and glue the **stab bracing** in place.
- 7. Remove the pins and sand the top and bottom of the stab smooth. **Note:** Be careful not to sand any dips in the stab bracing.
- 8. Sand the leading edge and the tips to a rounded shape as shown on the plan.

Build the Elevator

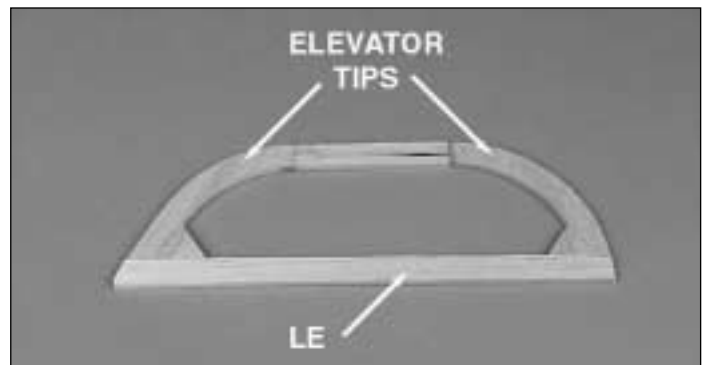

- □ 1. Pin the two die-cut 3/16" balsa **elevator tips** to the plan. **Note:** There is a difference in the shape of the inboard and outboard tips.
- □ 2. Using a 3/16" x 1/2" x 24" balsa stick, fit and glue the leading and trailing edge in place.



- □ 3. Using a 3/16" x 3/16" x 24" balsa stick, fit and glue the five **elevator ribs** in position.
- □ 4. Unpin the elevator half and set aside.

- 5. Repeat steps 1 through 4 to build the second elevator half.



- 6. Pin one elevator half in place on the plan, making sure the elevator is right side up. Position the second elevator half over the plan, making sure it is a mirror image of the pinned half. Use a straight edge, held against the LE of the pinned down half, to ensure the elevator halves are aligned. Pin the second half in place.

- 7. Trim the leading edges to accept the 3/16" x 3-1/2" dowel. Glue the dowel to both halves with medium CA. Remove the elevator from the building board.

- 8. Fill the area around the dowel with Hobbico HobbyLite balsa-colored filler. Set the elevator assembly aside and let the filler dry.

Build the Fin

- 1. Cover the fin and rudder section of the plan with Great Planes Plan Protector.

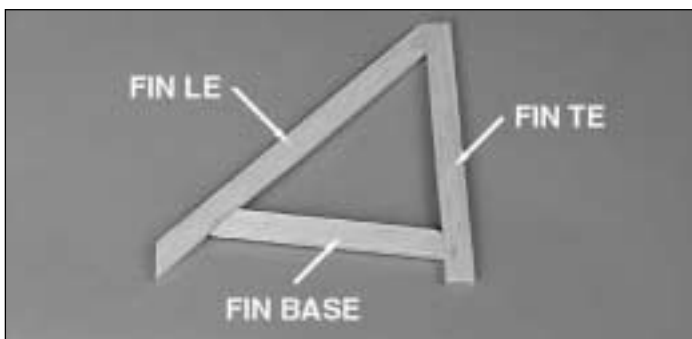

- 2. From a 3/16" x 1/2" x 24" balsa stick, fit and glue the **fin trailing edge, fin base** and the **fin leading edge**. **Note:** The fin trailing edge stops at the top of the stab. It does not go to the bottom of the fuse.

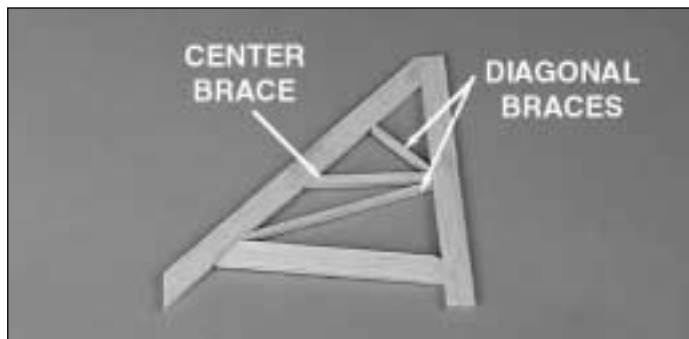

- 3. From a 3/16" x 3/16" x 24" balsa stick, fit and glue the **center fin brace** in position.

- 4. From a 1/8" x 3/16" x 24" balsa stick, fit and glue the two **diagonal fin braces** in place.

- 5. Remove the fin from the work surface and sand both sides smooth.

Build the Rudder

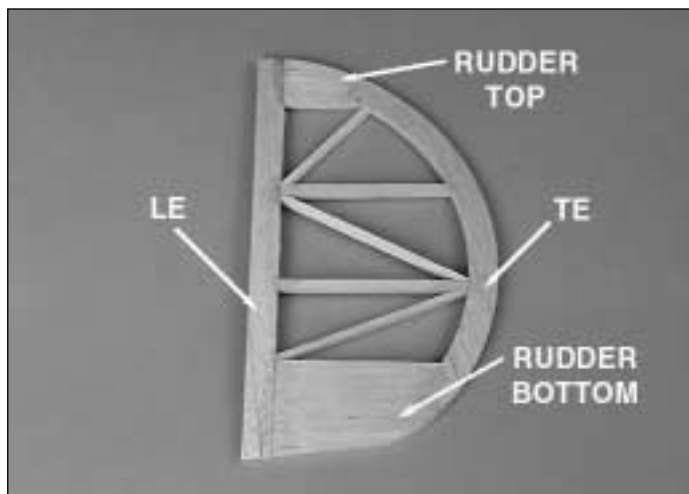

Refer to this photo for the following 6 steps.

- 1. From a 3/16" x 1/2" x 24" balsa stick, cut and pin the **rudder leading edge** in place on the plan.

- 2. Glue the die-cut 3/16" balsa **rudder bottom** and **rudder top** to the rudder leading edge.

- 3. Glue the die-cut 3/16" balsa **rudder trailing edge** to the rudder top and bottom.

- 4. From a 3/16" x 3/16" x 12" balsa stick, fit and glue the two horizontal **rudder braces** in place.

- 5. From a 1/8" x 3/16" x 24" balsa stick, fit and glue the three **diagonal rudder braces** in place.

- 6. Remove the rudder from the work surface and sand both sides smooth.

Hinge the Tail Surfaces

- □ 1. Place the stab over its location on the plan. *Lightly* mark the hinge locations on the trailing edge with a ball point pen. Mark the hinge locations on the elevator in the same manner.



We have simplified the task of cutting hinge slots with the introduction of the **Great Planes Slot Machine™**. This simple electric tool cuts a perfect width slot for use with CA hinges.



To cut the hinge slot, place the blades onto the wood where you want the slot. Lightly press the teeth into the wood. When you are satisfied with the location, press the button on the handle and the blades will cut easily into the balsa wood.

If you choose not to purchase a Slot Machine™ you can make the slots by following these instructions.

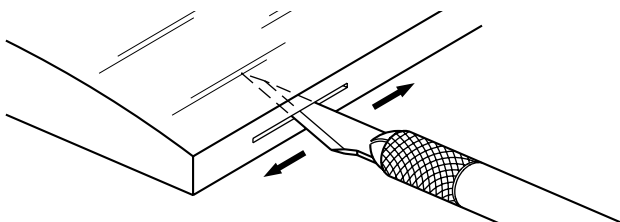

- □ 2. Cut the hinge slots in the elevator and stabilizer using a #11 blade. Begin by **carefully** cutting a very shallow slit at

the hinge location to accurately establish the hinge slot. Make three or four more cuts, going a little deeper each time. As you cut, slide the knife from side to side until the slot has reached the proper depth and width for the hinge.

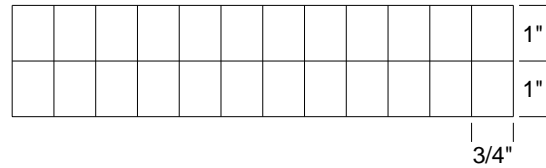

- □ 3. Cut 3/4" x 1" hinges for the elevator from the supplied 2" x 9" **hinge material**, then snip off the corners. Temporarily join the elevator to the stab with the hinges, adjusting any hinge slots if necessary so they all align. **Do not glue in the hinges until you are instructed to do so.**
- 4. Repeat steps 1 through 3 to hinge the rudder and fin.

Finish the Tail Surfaces

- 1. Shape the leading edge of the elevator and rudder to a "V" as shown on the plan.
- 2. Sand both sides of the elevator assembly smooth.
- 3. Use a bar sander and 150-grit sandpaper to round the tail surfaces, as shown on the plan.

BUILD THE WING

Build the Wing Center Section

Note: All of the wing ribs have been partially die-cut at the bottom of the trailing edge. Use a hobby knife to complete the die-cut.

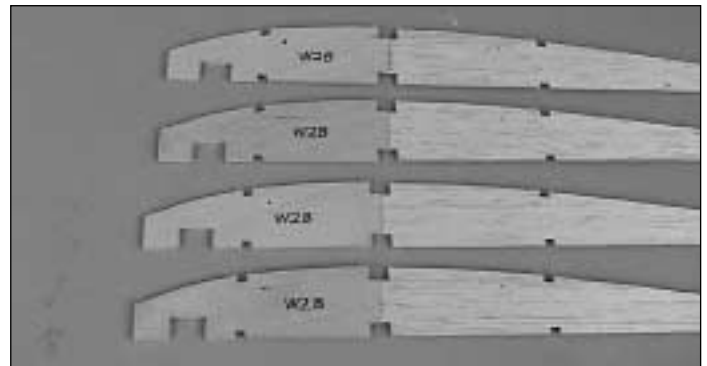

- 1. Glue four die-cut 1/32" ply **W2B**'s to the four die-cut 1/16" balsa **W2** ribs. Glue four more W2Bs to the other side of the four W2 ribs. **Note:** Each of these rib assemblies is now referred to as W2.
- 2. Drill two 1/8" holes at the punch marks in each of the four W2 ribs. Drill two 1/8" holes at the punch marks in each of the two die-cut 1/8" balsa **W3** ribs.

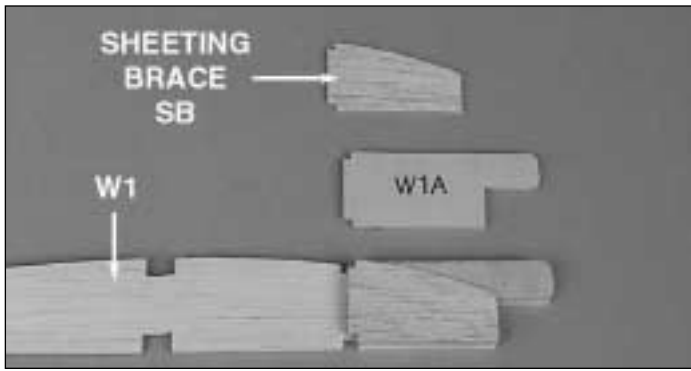

□ 3. Glue a die-cut 1/8" ply **W1A** to the die-cut 1/8" balsa **W1 rib**. Glue the die-cut 1/16" balsa **Sheeting Brace SB** to W1A. Glue the second W1A and the second sheeting support to the other side of the W1 rib. **Note:** This rib assembly is now referred to as W1.

□ 4. Lay the wing plan on the building board. **Hint:** You may cut the wing plan section from the plan. Don't forget to cover it with Great Planes Plan Protector.

□ 5. Cut the two 1/4" x 3/8" x 24" balsa sticks to 21-3/16" long, making two **main spars**. Pin the bottom main spar in place over the plan. **Note:** The T-pins need to go into the spar at an angle from the front so that they will not interfere with the top spar or the shear webs.

□ 6. Cut six 1/8" x 3/16" x 24" balsa sticks to 21-3/16" long, making the **auxiliary spars**.

□ 7. Position three auxiliary spars over the plan. **Note:** Do not pin them in place.

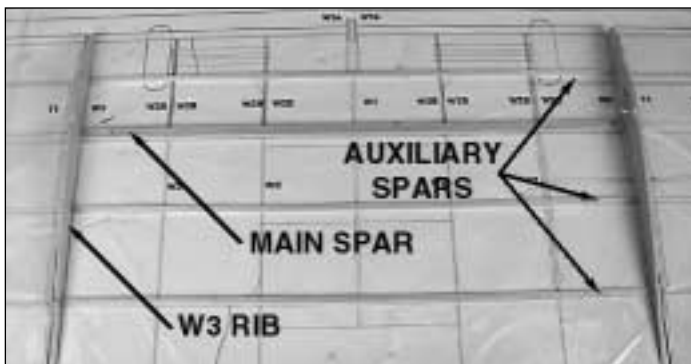

□ 8. Making sure to keep the W3 ribs perpendicular to the building board, position the ribs and glue them to the main spar and the auxiliary spars.

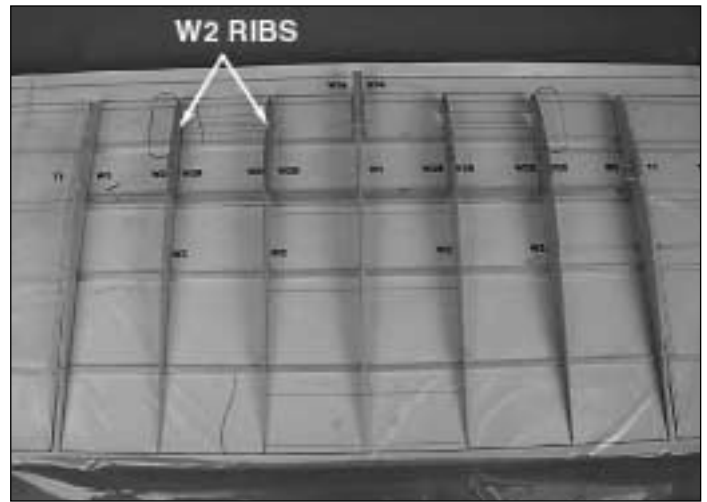

□ 9. Position and glue the W1 rib and the four W2 ribs in place.

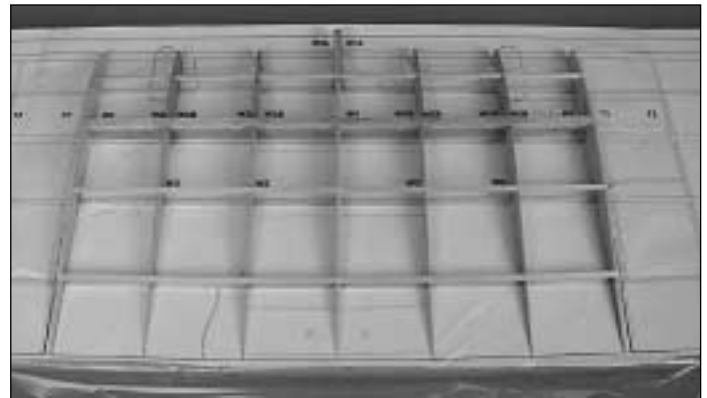

□ 10. Position and glue the 1/4" x 3/8" x 21-3/16" balsa **top main spar** in the ribs.

□ 11. Position and glue the 1/8" x 3/16" x 21-3/16" balsa **top auxiliary spars** to the ribs.

□ 12. From a 1/16" x 5/8" x 24" balsa sheet, cut two 10-7/16" long pieces, making two **sub leading edges**.

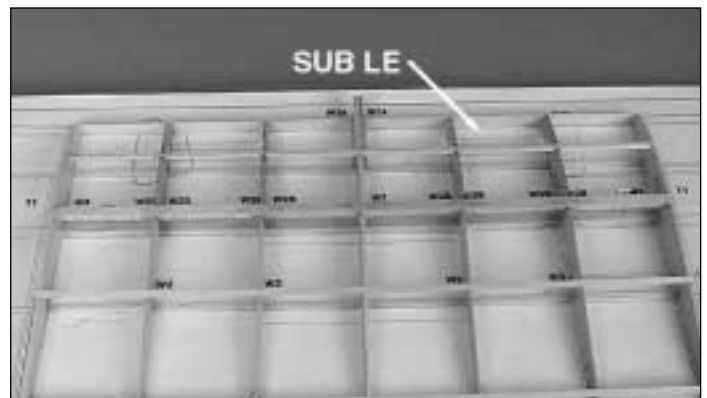

□ 13. Position and glue both 10-7/16" sub leading edges to the front edge of the ribs.

SAND HERE

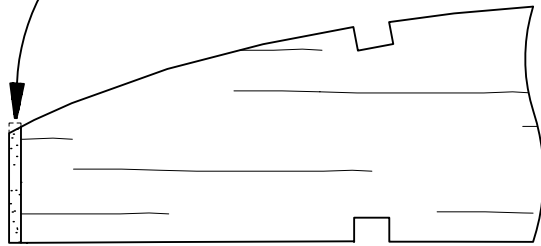

- 14. Sand the top of the sub leading edge to the shape of the ribs.

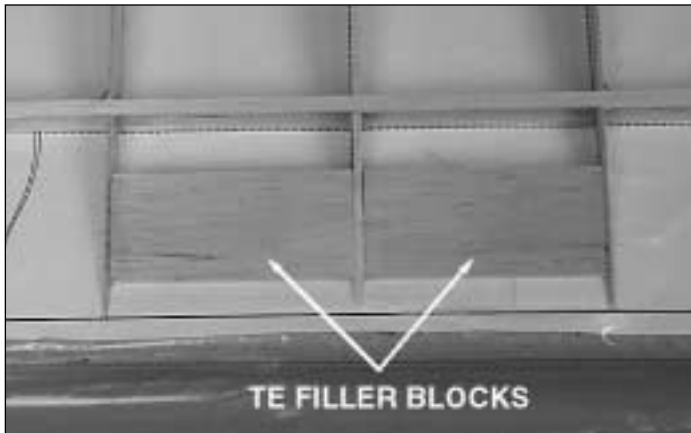

- 15. From the shaped 6-3/4" balsa TE filler block, cut, fit and glue the two **TE filler blocks** in place.

- 16. From the 1/16" x 3" x 12" balsa sheet, cut, fit and glue the six **shear webs** in place on the TE of the spars.

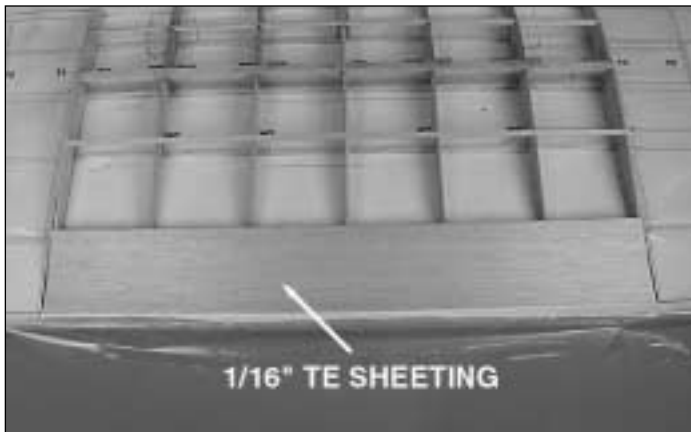

- 17. Position the 1/16" x 3" x 24" balsa **TE sheeting**, aligning the trailing edge of the sheeting with the TE of the wing shown on the plan. Glue it in place. Trim the excess sheeting which extends outboard past ribs W3. **Note:** Be sure to align it with the wing plan, **not** the aft end of the ribs.



- 18. From a 1/16" x 3" x 24" sheet, cut a 10-7/16" long **LE sheet**. Position the LE sheet, aligning the rear of the LE sheet with the center of the forward auxiliary spar and glue it in place.



- 19. Remove the T-pins from the spar. From a 1/16" x 3" x 30" balsa sheet, cut three 7-1/4" long **center sheets**. See the Expert Tip which follows, then edge glue the center sheets together. Fit, cut and glue this center sheet to the W1 and W2 ribs as shown on the plan.



HOW TO MAKE WING SHEETING

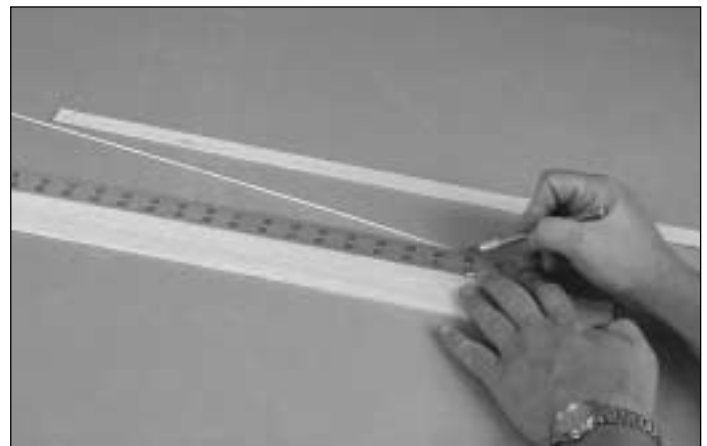

- A. Use a metal straightedge as a guide to trim one edge of both sheets.

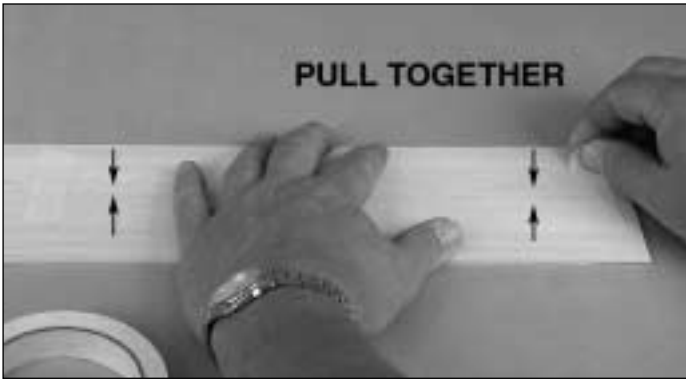

B. Use masking tape to tightly tape the two sheets together joining the trimmed edges.



C. Turn the sheet over and apply weights on top of the sheet to hold it flat. Apply thin CA sparingly to the seam between the two pieces, quickly wiping away excess CA with a paper towel as you proceed.

D. Turn the sheet over and remove the masking tape, then apply thin CA to the seam the same way you did for the other side.

E. Sand the sheet flat and smooth with your bar sander and fresh 150-grit sandpaper.



□ 20. Using two 1/16" x 1/4" x 24" balsa sticks, fit and glue cap strips to the top edge of the four exposed ribs.

□ 21. Trim the LE sheeting flush with the front of the sub leading edge.

□ 22. Remove the wing center section from the building board. Sand the sheeting and the cap strips flush with both W3s.



□ 23. Use a 1/4" x 1/2" x 24" balsa stick as your **trailing edge jig**. Pin it to the plan, over the aft auxiliary spar. Position the wing upside down over the plan, with the auxiliary spar aligned with the trailing edge jig as shown in the photo. Weight the middle of the wing to hold it in position. **Hint:** Ankle weights or bar sanders with sealed bags of shot work very well.

□ 24. Position a 1/16" x 3" x 24" balsa TE sheet aligned with the top TE sheet previously applied. Glue it to the ribs, the auxiliary spar and the filler block.



□ 25. Select the two 4-7/8" long basswood **landing gear rails**. Glue them into the W2 ribs with epoxy.

□ 26. Glue the **landing gear torque blocks** to the top side of the landing gear rails, flush with W2, as shown on the plan.

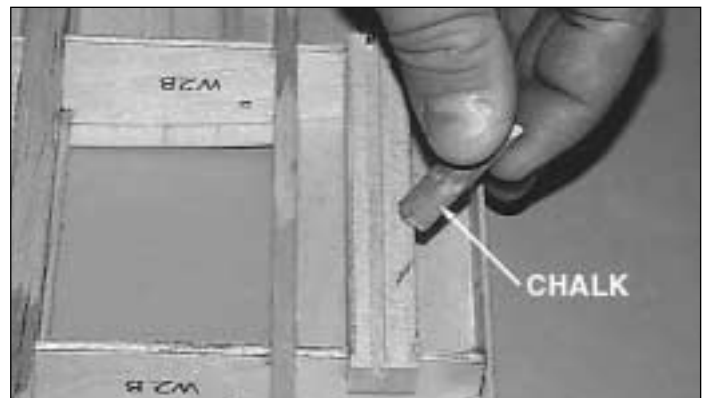

□ 27. Use a piece of chalk to mark the tops of the landing gear rails. Position a 1/16" x 3" x 24" balsa LE sheet aligned

with the center of the forward auxiliary spar as you did with the top sheeting. Press the sheet firmly against the landing gear rails so that the chalk will mark the location of the landing gear rails on the sheeting. **Note:** Be careful to hold the sheet in position as you do so.



□ 28. Remove the sheet from the wing. Cut out the areas marked with chalk. Test fit the sheet onto the wing. When satisfied with the fit, glue the sheet to the auxiliary spar, ribs, sub leading edge and landing gear blocks with medium CA.

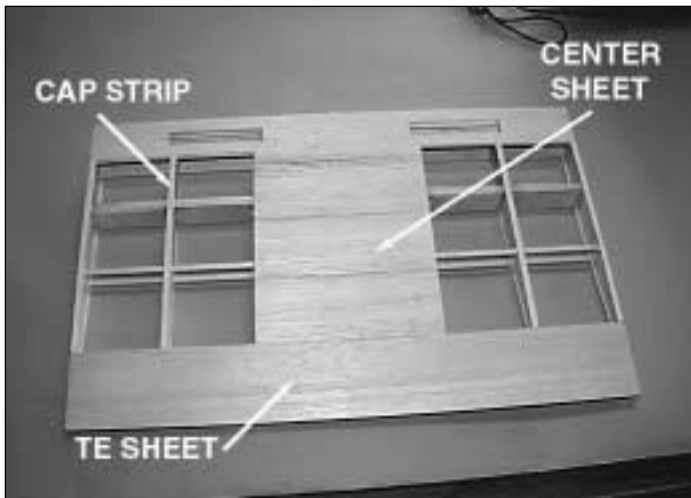

□ 29. Use a 1/16" x 3" x 30" balsa sheet to sheet the center of the panel. Use two 1/16" x 1/4" x 24" sticks to cap the ribs.

□ 30. Trim and sand the leading edge sheeting flush with the sub leading edge. Trim and sand the leading edge and trailing edge sheeting flush with both W3s. **Note:** The leading edge will be applied after the wings are joined.

□ 31. Measure 1/2" outboard from the inboard end of the gear rails. Drill a 5/32" hole through each rail, being careful not to drill through the top of the wing.

Build the Outer Wing Panels

□ □ 1. Cover the right outer wing panel plan with Plan Protector. Pin the die-cut 1/16" balsa **TE sheeting** in position.

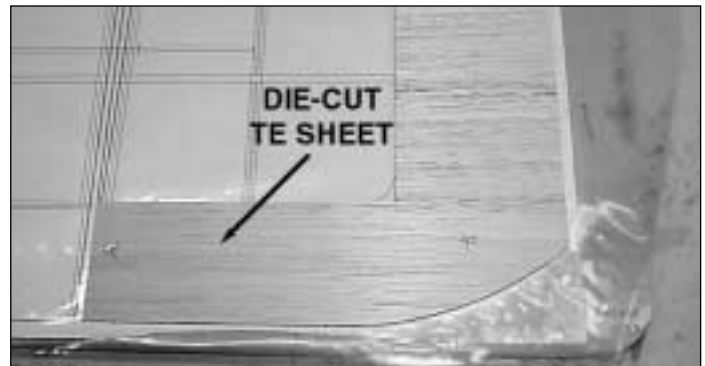

□ □ 2. From a 1/16" x 3" x 30" balsa sheet, cut three 4-1/8" long pieces.

□ □ 3. Edge glue one of the 4-1/8" sheets against the front of the TE sheet. Glue a second and third sheet in position as shown on the plan and the following photo. Trim the width of the third sheet so that it aligns with the center of the auxiliary spar.

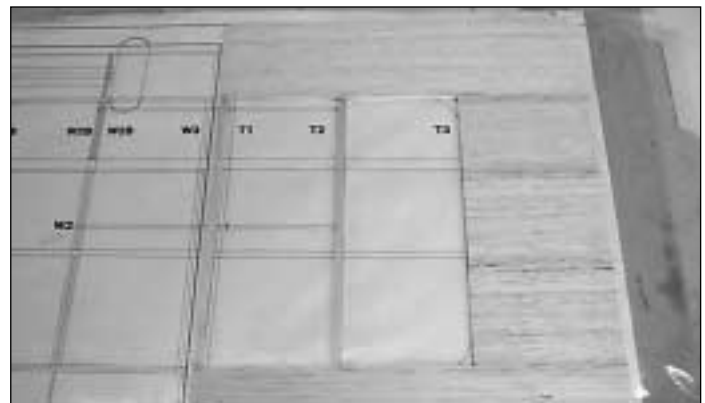

□ □ 4. From a 1/16" x 3" x 24" balsa sheet, cut a 11-7/16" long **LE sheeting**. Edge glue the sheet against the sheet you installed in step 3, aligned with the outboard end.

□ □ 5. From a 1/16" x 1/4" x 24" balsa stick, cut and glue cap strips in position over the plan. **Note:** The plan shows the top T1 cap strip, not the bottom. Position the T1 cap strip flush with the inboard edge of the LE and TE sheeting.

□ □ 6. From a 1/16" x 3/8" x 24" balsa stick, cut two 11-7/16" long **main spars**. From two 1/16" x 3/8" x 24" balsa sticks, cut two 8" long **main spar doublers**.

□ □ 7. From three 1/8" x 3/16" x 24" balsa sticks, cut six 11-3/8" long **auxiliary spars**.

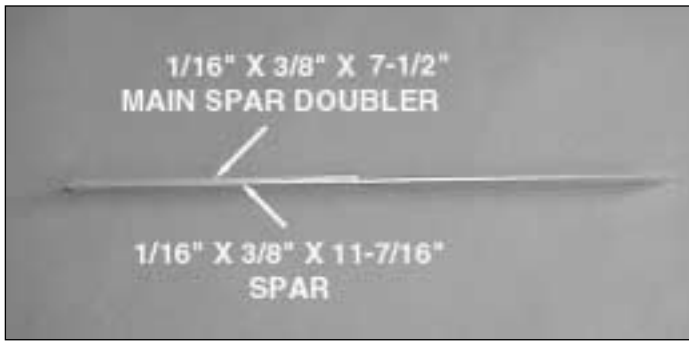

□ □ 8. Glue one main spar doubler onto each main spar, aligning one end of the doubler with the end of the main spar. **Note:** From here forward, this combination will be known as a spar. Set one spar aside for the top of this outer wing panel.

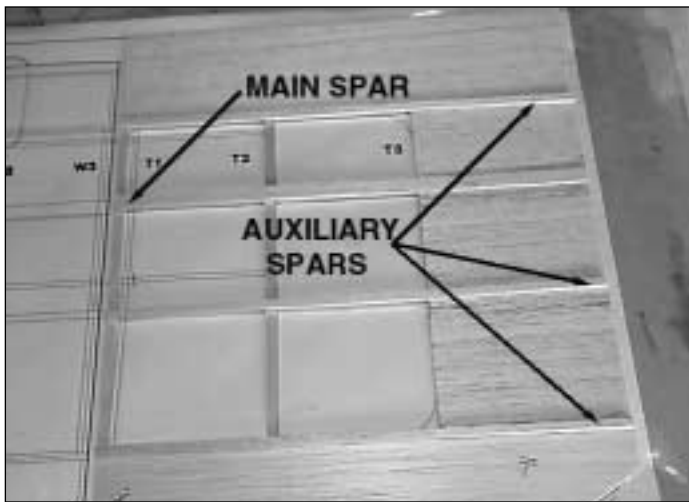

□ □ 9. Align one main spar over the plan with the doubler at the inboard end of this outer panel. Glue it to the cap strips and the sheeting.

□ □ 10. Align the three auxiliary spars (cut in step 7) over the plan with the 3/16" side against the plan. **DO NOT** glue them at this time.

□ □ 11. Select the 1/8" die-cut balsa **T1** rib and the 1/16" die-cut balsa **T2** rib. Drill 1/8" holes through the punchmarks in T1. Position T1 and T2 on the plan.



□ □ 12. Test fit the auxiliary spars and main spar into the ribs. When satisfied with the fit, use the die-cut 1/8" ply **DG gauge** to set the angle of T1 and glue T1 in place. Use a square to be sure T2 is vertical and glue it in place.

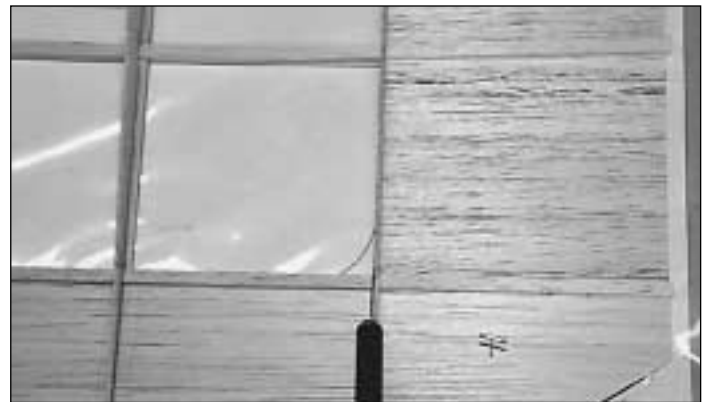

□ □ 13. Position the 1/16" die-cut balsa **T3** rib on the plan, aligned with the inboard edge of the center sheeting. Trim the rear auxiliary spar flush with the inboard edge of T3, being **EXTREMELY** careful not to cut the TE sheeting. Glue T3 in place, using a square to be sure it's vertical.



□ □ 14. Position the 1/16" die-cut balsa **T4** rib on the sheeting, aligned with the outboard edge of the sheeting. Trim the two auxiliary spars flush with the inboard edge of T4. Use a square to be sure T4 is vertical and glue it in place. Glue the auxiliary spars to the sheeting and ribs.



□ □ 15. Position the top main spar (you made in step 6) in all 4 ribs, with the doubler facing the plan and the bottom side of the inboard end of the main spar flush with T1. **Note:** A little of the top of the main spar will extend past the inboard end of T1. This will be sanded flush later.



□ □ 16. Insert the front and middle auxiliary spars into the tops of the ribs, aligning the outboard ends flush with the outboard edge of T4. Install the aft auxiliary spar in its notches in ribs T1, T2 and T3, aligning the outboard end halfway between T3 and T4 (we will trim the excess later). Glue the main spar and the auxiliary spars in place.

□ □ 17. From a 1/16" x 5/8" x 24" balsa stick, cut an 11-7/16" sub leading edge. Align the sub leading edge flush with the outboard edge of T4 and glue in place. **Note:** Save the leftover piece for the left outer panel.

□ □ 18. Sand the sub leading edge to the shape of the ribs as you did with the center wing panel.

□ □ 19. Unpin the bottom TE sheet and lift the wing off the plan.

□ □ 20. Trim and sand the LE sheeting flush with the front of the sub leading edge.

□ □ 21. Position the top (die-cut) TE sheet, aligning it with the edges of the bottom TE sheet. Glue it in place.

□ □ 22. From the leftover 1/16" x 3" balsa sheet, cut three 4-1/8" long sheets and edge glue them in position as you did with the bottom sheeting. **Hint:** Remember to trim the third piece along the center of the front auxiliary spar.

□ □ 23. From a 1/16" x 3" x 24" balsa sheet, cut an 11-7/16" long LE sheet. Edge glue it in position as you did with the bottom sheeting.

□ □ 24. From a 1/16" x 1/4" x 24" balsa stick, cut and glue cap strips in position on T1 and T2. **Hint:** Align the top cap strip on T1 flush with the inboard edge of T1.

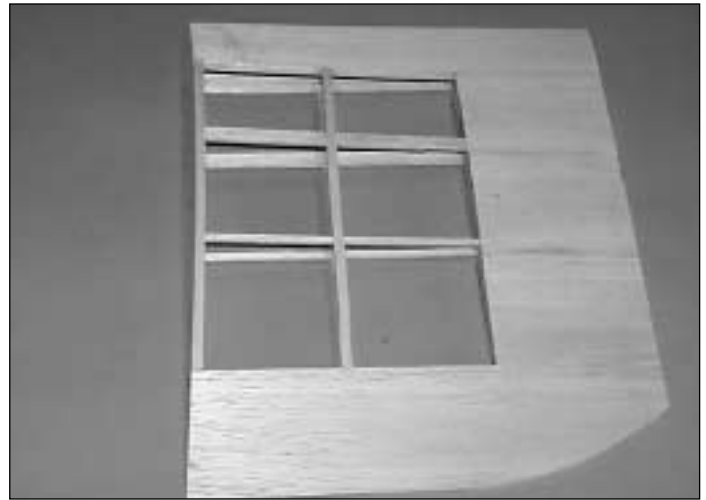

□ □ 25. Trim and sand the top LE sheeting flush with the sub leading edge. Trim and sand the spars and sheeting flush with T1 and T4. **Note:** Be careful not to change the angle of T1.

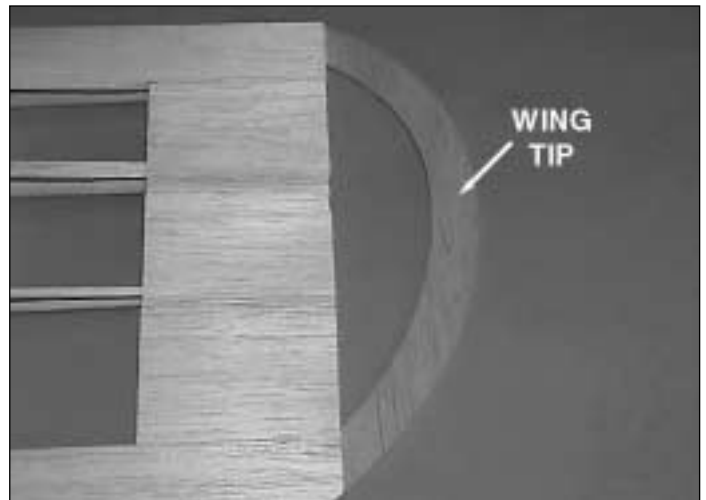

□ □ 26. Position and glue the die-cut 1/8" balsa **wing tip**, aligning it with the trailing edge and flat on the building surface. **Note:** The wing tip will not come all the way to the front of the sub leading edge.

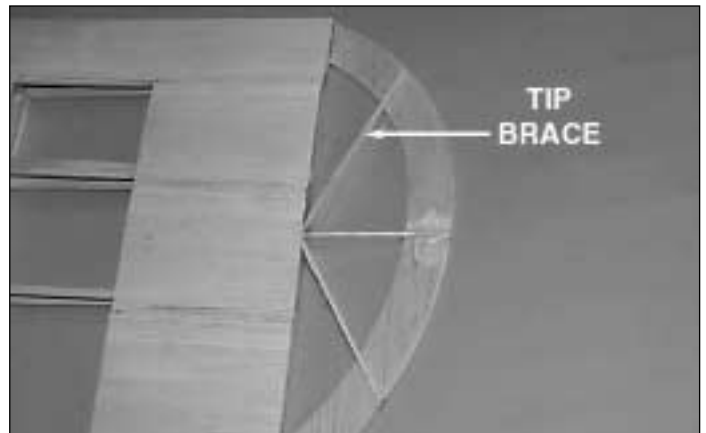

□ □ 27. Position and glue the three die-cut 3/32" balsa **tip braces** as shown on the plan.

Repeat steps 1-27 to build the left outer wing panel.

Finish the Wing

- □ 1. From a 1/8" x 18" dowel, cut four 4" long **wing joiners**.

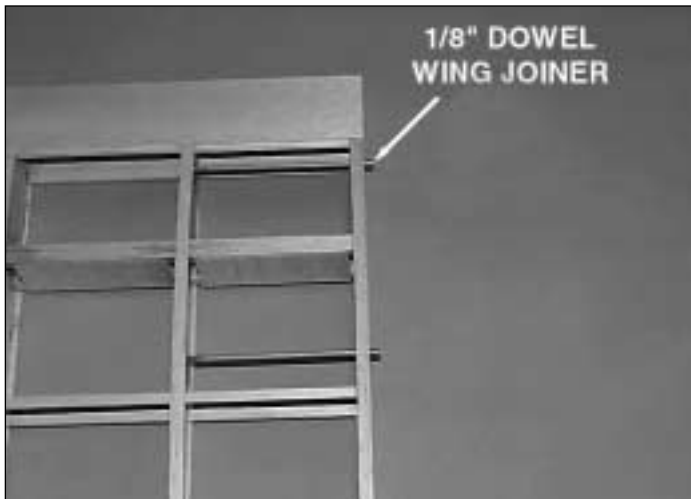

- □ 2. Slide the first wing joiner through the forward hole in rib W3 (the right side of the wing center section) and the forward hole in the first W2 until it is flush with the inboard edge of W2. Slide the second wing joiner into the aft holes in W2 and W3, aligned as you did the forward joiner. Glue both wing joiners into W2 and W3. Lay Plan Protector over the building surface and place the wing center section flat on the Plan Protector.



- □ 3. Carefully slide the outer wing panel onto the two wing joiners until flush with the center wing section. Support the outboard tip of the outer wing panel 3-1/4" above the building surface. Adjust the dowel holes slightly if required to properly position the outer wing panel and to properly align the outer wing panel to the wing center section. When satisfied with the fit, glue the outer panel to the center section with epoxy and glue the wing joiners to ribs T1 and T2. **Note:** Do not disturb the wing until the epoxy has fully cured.

- □ 4. Repeat steps 1 through 3 to join the left outer panel to the wing center section.

- □ 5. Sand all three sub leading edges flush with each other.

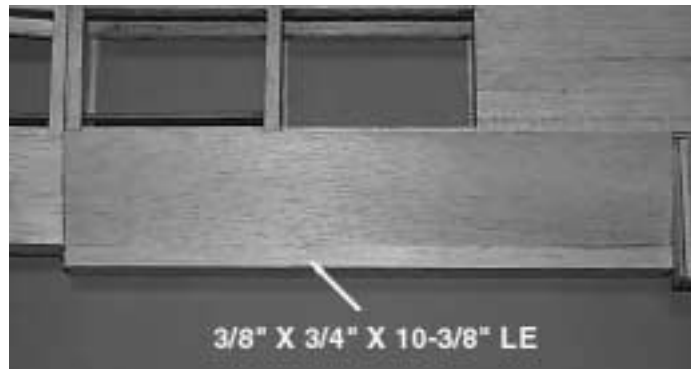

- □ 6. From a 3/8" x 3/4" x 24" balsa stick, cut a 10-3/8" long **leading edge** for the right half of the center section. Glue it to the sub leading edge and LE sheeting.

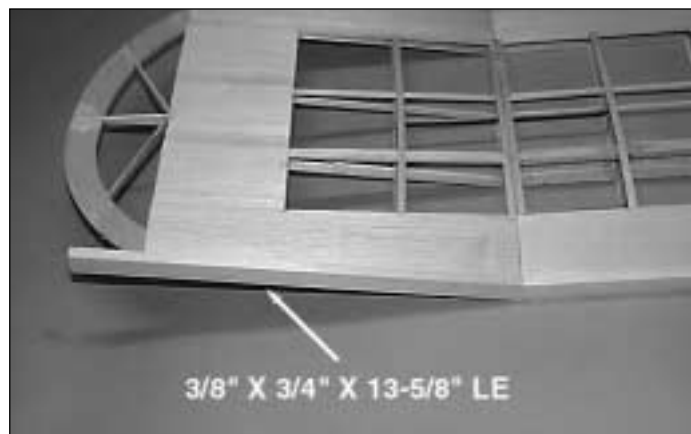

- □ 7. Sand a taper onto the leftover 3/8" x 3/4" x 13-5/8" balsa **leading edge** for the right outer wing panel so that it fits snugly against the center section leading edge. Glue it in place.

- □ 8. Trim the outer panel leading edge flush with the outboard edge of T4. Razor plane and sand the leading edge on the outer panel and center section to the shape shown on the plan.

- □ 9. Repeat steps 6 through 8, installing the leading edge on the left half of the wing.

BUILD THE FUSELAGE

Assemble the Fuse Formers & Sides

- 1. Cover the fuse side view with Great Planes Plan Protector.

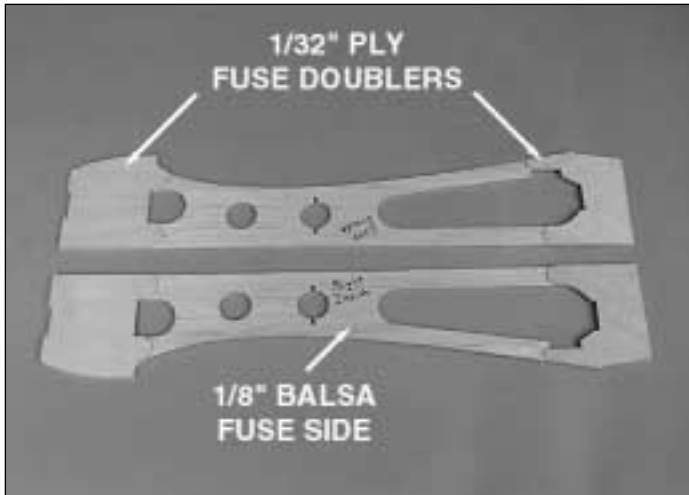

- 2. Glue two die-cut 1/32" ply **fuse doublers** to the inside of each die-cut 1/8" balsa **fuse side** as shown. Label them "right side" and "left side" on the insides of the fuse sides. It is important that you have the fuselage sides in a mirrored position to ensure that you build a left and a right side. **HINT:** To help you recognize left from right fuse sides, set the sides upright and pretend you are in the cockpit.

- 3. Pin the right fuse side in place over the plan.

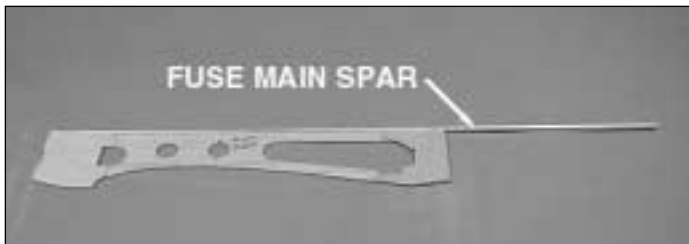

- □ 4. From a 1/8" x 3/16" x 36" balsa stick, cut a 28-1/2" long **fuse main stringer**. Glue it to the top of the right fuse side with the 1/8" side against the building board.

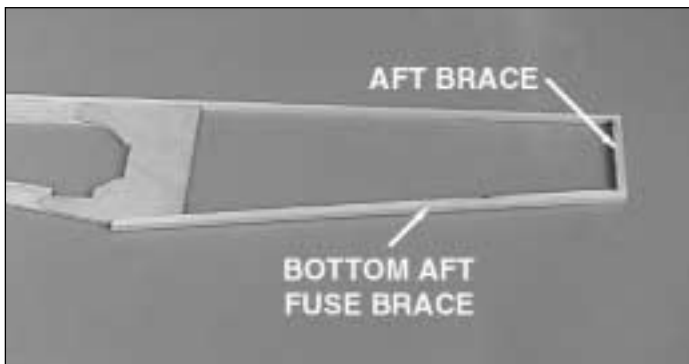

- □ 5. From a 3/16" x 3/16" x 30" balsa stick, fit and glue the **bottom aft fuse stringer** and the **aft fuse brace** in place.

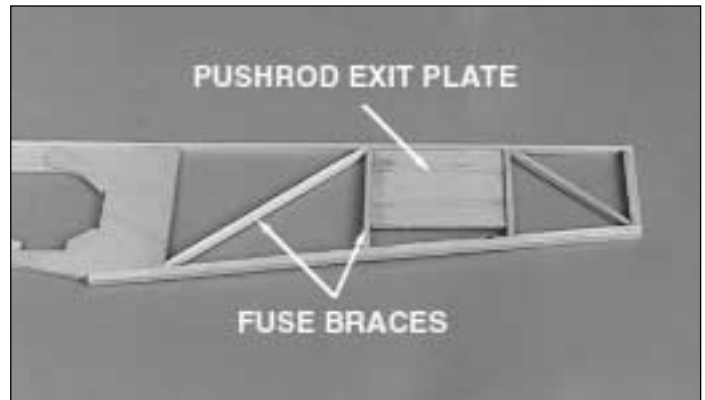

- □ 6. Glue the die-cut 1/8" balsa **pushrod exit plate** in place.

- □ 7. From a 1/8" x 3/16" x 24" balsa stick, fit and glue the four **fuse braces** in place.

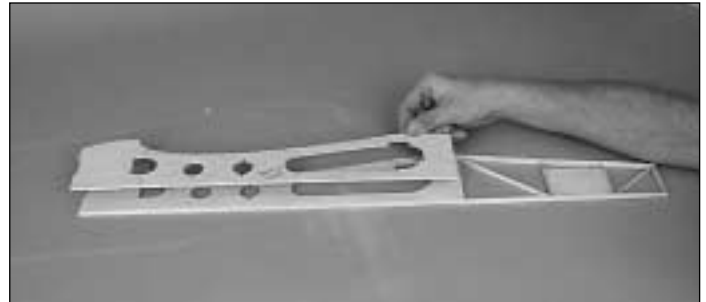

- 8. Unpin the right fuse side from the plan and turn it over. Cover the right fuse side with Plan Protector and pin the left fuse side **on top** of the right fuse side. **Note:** The left side is built the same as the right, except it is built over the right fuse side, not the plan.

- 9. Repeat steps 4 through 7 to build the left fuse side.

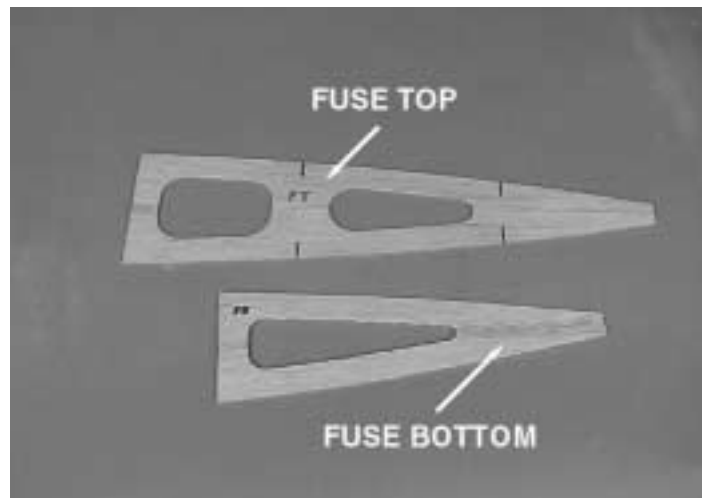

- 10. Glue the two die-cut 1/16" balsa **fuse top halves** together, making the fuse top. Glue the two die-cut 1/16" balsa **fuse bottom halves** together, making the fuse bottom.

- 11. Cover the fuse top view with Plan Protector.



□ 12. Position and pin the die-cut 1/8" ply **servo tray** on the plan.

□ 13. Glue the fuse top in place against the servo tray.

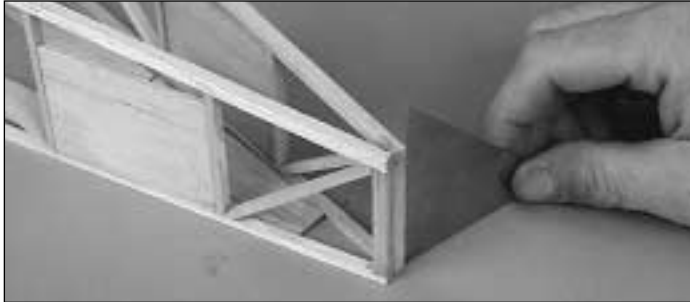

□ 14. Align the aft end of the two fuse sides over the plan, making sure to keep them perpendicular to the work surface. When satisfied with the fit, glue the trailing edges of the fuse sides together.



□ 15. Fit and glue the shaped 2-3/4" long balsa **tail post** in place.



□ 16. Drill a 3/16" hole through each of the two punchmarks in the die-cut 1/8" ply former **F5** and the die-cut 3/32" balsa former **F4B**.

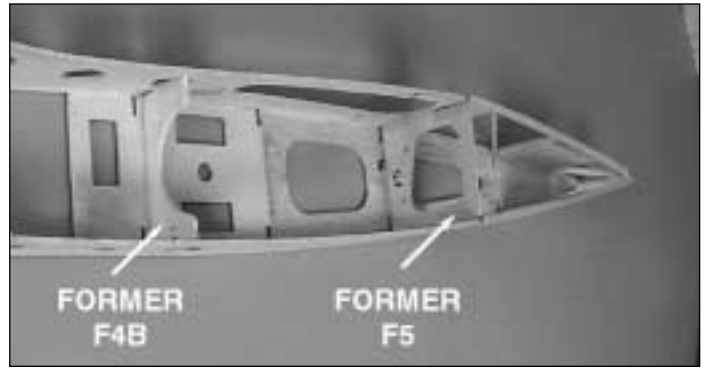

□ 17. Pull the fuse sides against the fuse top, fitting the die-cut 1/8" balsa formers **F3** and **F5** as you go. **Note:** The embossed labels on F3 and F5 face the front of the plane and are upside down on the work surface at this time.

□ 18. Confirm that the fuse sides are perpendicular to the work surface with a square, then glue the fuse sides to the formers and the fuse top.

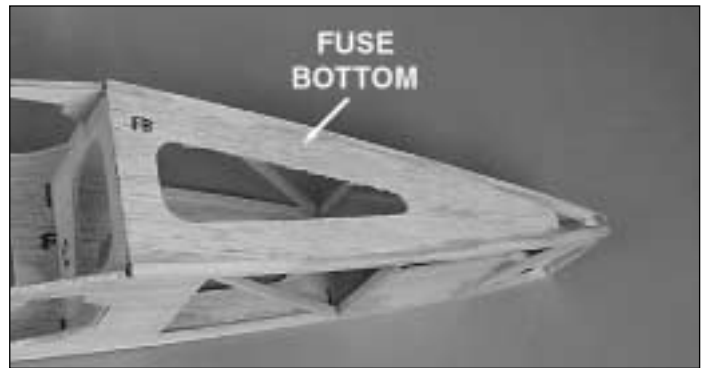

□ 19. Fit and glue the fuse bottom in place, aligning it with the front edge of F5.

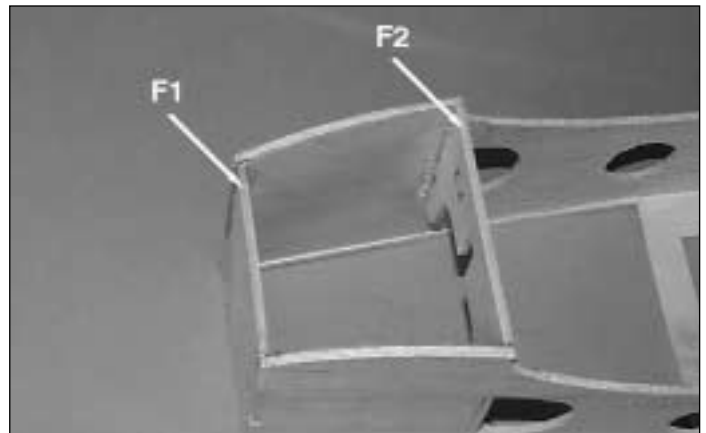

□ 20. Keeping the fuse sides aligned over the plan, position the die-cut 1/8" ply formers **F1** and **F2**. Using a square to be sure your fuse sides are vertical while still keeping them aligned over the plan, glue F1 and F2 to the fuse sides.

□ 21. Glue the die-cut 1/8" ply **F2B** former to the front of F2, aligning the slots and the bottoms of the formers.

□ 22. Laminate the two die-cut 1/8" ply **wing bolt plates (WBP)** together.

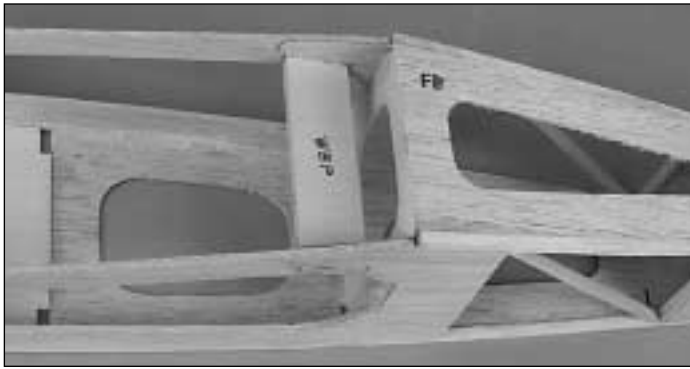

□ 23. Use 6-minute epoxy to glue WBP to the fuse sides.

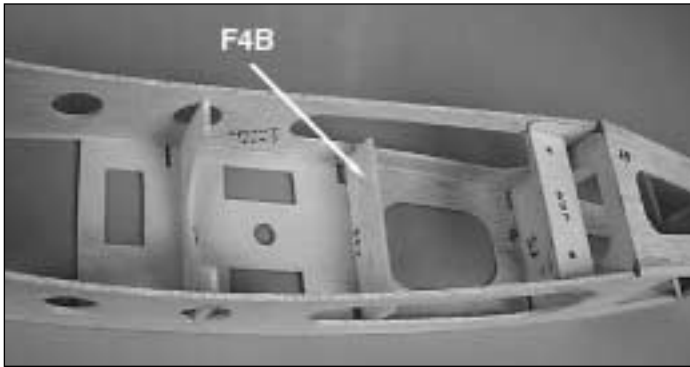

□ 24. Position the die-cut 1/8" ply **F4B** former vertically and flush with the front of the fuse top. Glue it in place.

Mount the Wing

- 1. Lightly sand the wing saddle area.
- 2. Fit the wing to the fuse. If the wing chord is too wide, sand the TE of the wing until the wing fits cleanly in the fuse.

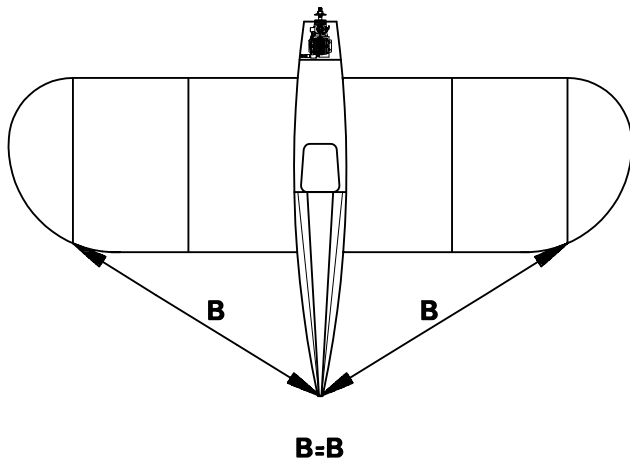

□ 3. Stick a T-pin through the center of the aft end of the fuselage bottom. Tie a string to the T-pin. Pull the string to

the TE of the wing tip and put a piece of masking tape on the string near the wing tip. Mark an arrow on the tape, then slide the tape on the string so the arrow aligns with the wing tip. Swing the string over to the other tip and see if it aligns with the same point. If it does not, shift the wing and mark the new location of the tip by adjusting the position of the tape on the string. Do this until the arrow on the string aligns with both tips.

□ 4. Measure 1" forward from the TE of the wing and draw a line parallel to the TE across the width of the fuse.

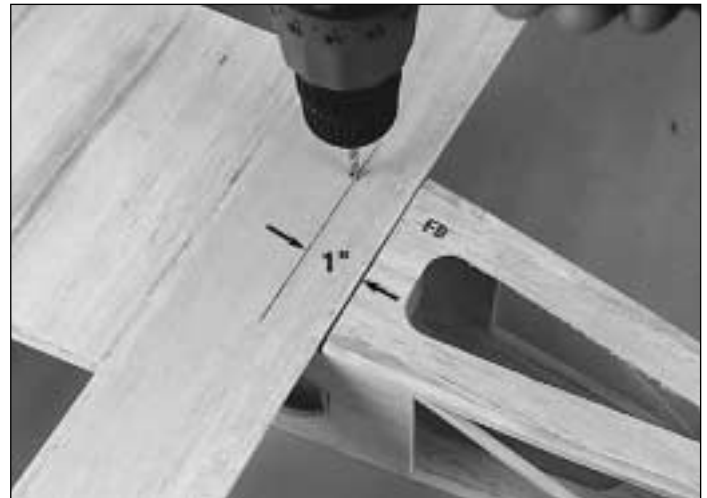

□ □ 5. Keeping the wing aligned with the fuse, drill a 5/32" hole through the wing and the WBP on the line, 1/2" inside the edge of the fuse side.

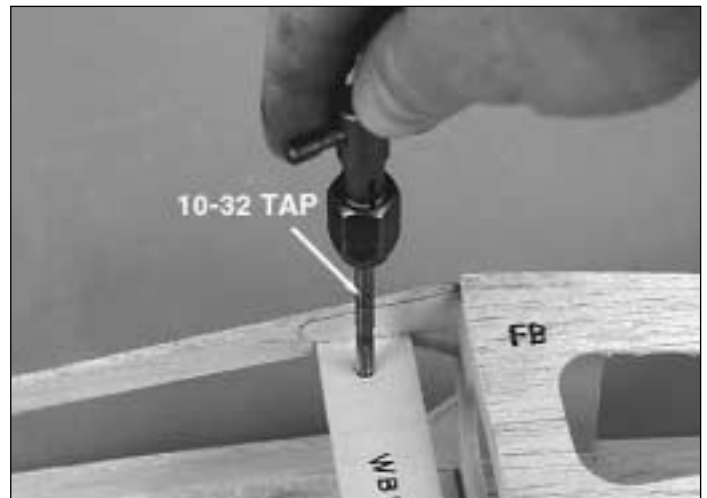

□ □ 6. Remove the wing. Tap the hole in WBP with a 10-32 tap. Enlarge only the hole in the wing to 13/64".

□ 7. Bolt the wing to the fuse with the one 10-32 x 2" nylon bolt. Repeat steps 5 and 6, drilling and taping the second bolt hole.

□ 8. Harden the threads in WBP with thin CA. After the CA has fully cured, retap the holes to clean up the threads.

Mount the Engine

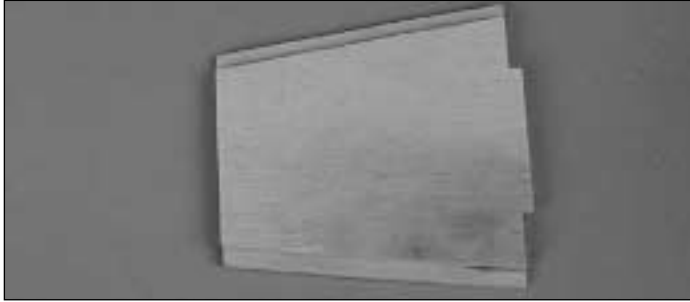

□ 1. Laminate the two die-cut 1/8" ply **engine mounts** together, with 6-minute epoxy, making sure to keep the punch marks on the larger mount visible.

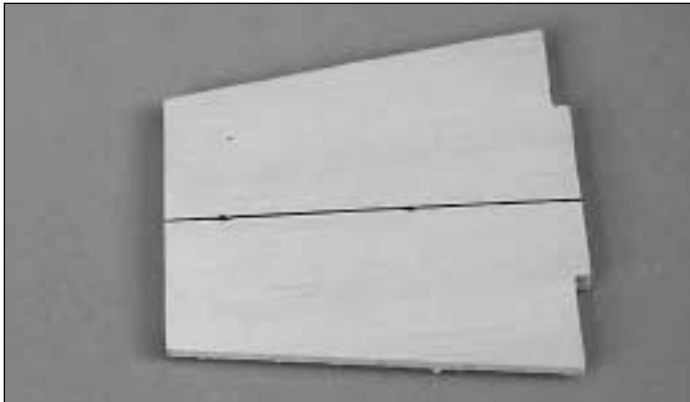

□ 2. Draw a line from front to back on the engine mount, using the punch marks as a guide.

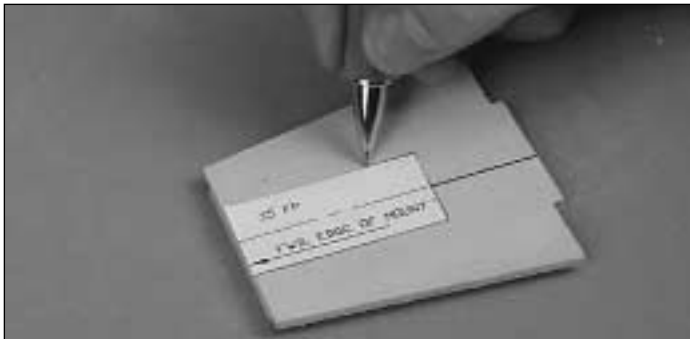

□ 3. Cut the template for your engine from the plan. Place the template on the line you drew, aligning it with the front of the engine mount. Trace around the edges of the template onto the engine mount.

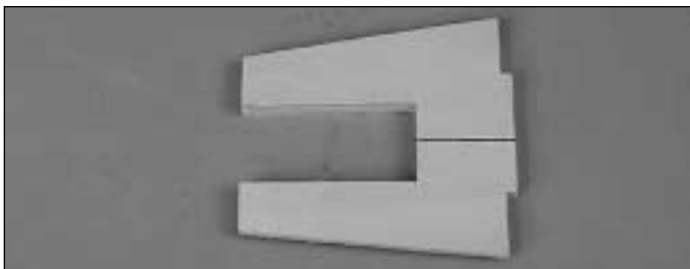

□ 4. Using your tracing as a guide, cut the engine mount to accept your engine.

□ 5. Position the engine on the mount so there is a 1/16" gap between the rear of the engine and the slot in the mount.

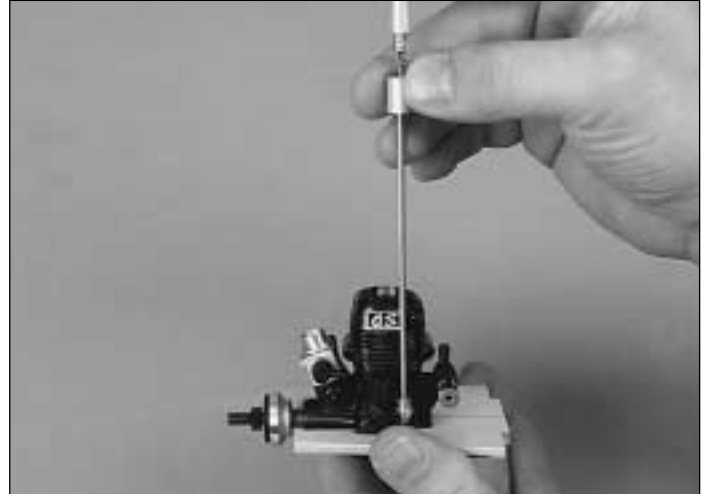

□ 6. Mark the engine mount holes with a pencil lead or a T-pin. Remove the engine from the mount and drill four 9/64" holes at your marks. **Hint:** For greater accuracy use the Great Planes Dead Center™ Engine Mount Hole Locator (GPMP8130) to mark the locations of the bolt holes.

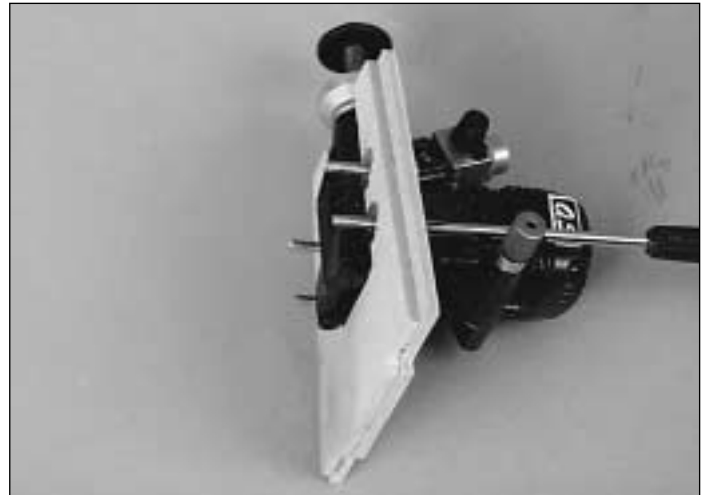

□ 7. Use the four 4-40 x 3/4" bolts to pull the four 4-40 blind nuts into the bottom of the engine mount or seat them with a hammer.



□ 8. Glue the blind nuts into the engine mount by wicking thin CA around the outside edges. **Note:** Be careful not to glue the bolts to the blind nuts.

- 9. Remove the engine from the engine mount.

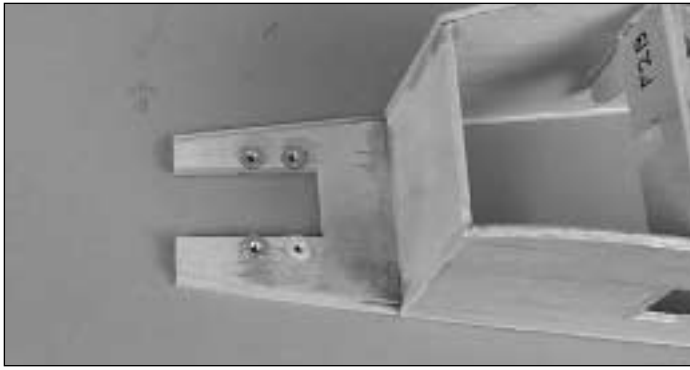

- 10. Place the fuselage, inverted, onto the building surface. Position and glue the engine mount flush with F1.

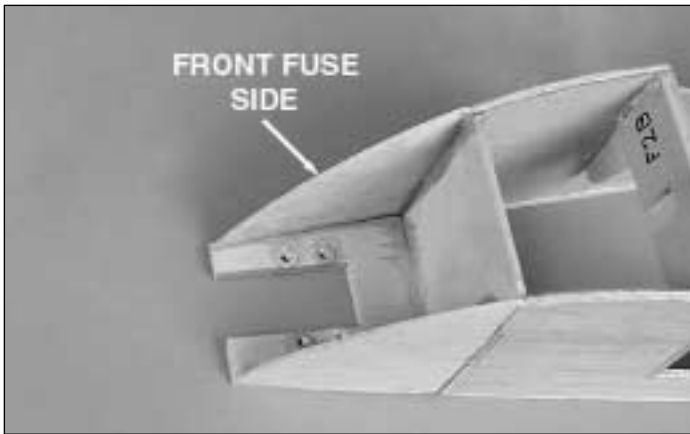

- 11. Locate the two die-cut 1/8" balsa **front fuse sides** and the two die-cut 1/8" balsa **front fuse doublers**. Paying special attention to keep the engine mount and the fuse flat on the work surface, glue the two front fuse **sides** in place to the sides of the engine mount. **Note:** The front fuse doublers are smaller than the front fuse sides.

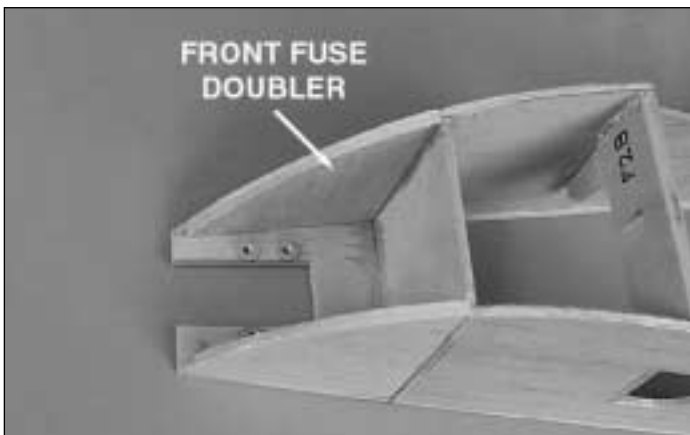

- 12. Glue the front fuse **doublers** in place to the **insides** of the front fuse sides.

- 13. Fuelproof the wood on the inside of the front fuse doublers, the front of F1 and the bottom of the engine mount. **Hint:** Fuel proof paint or epoxy thinned with alcohol works well.

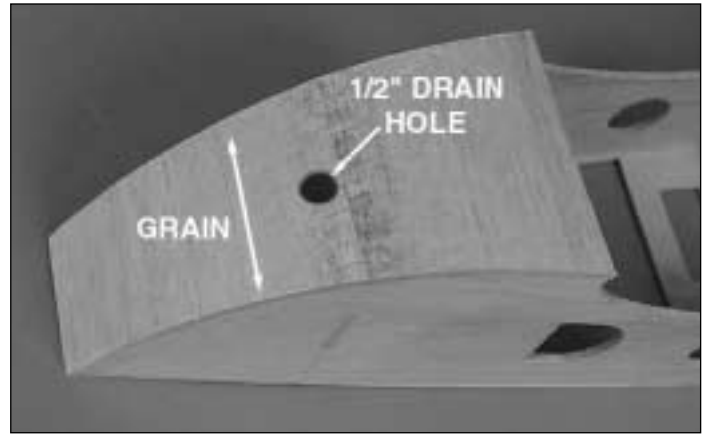

- 14. Using a piece of 1/8" x 3" x 12" balsa, sheet the front bottom from F2 up to and overlapping the engine mount. **Note:** Be sure the grain is running across the fuse bottom, not along it.

- 15. A 1/2" drain hole should be positioned as shown above.

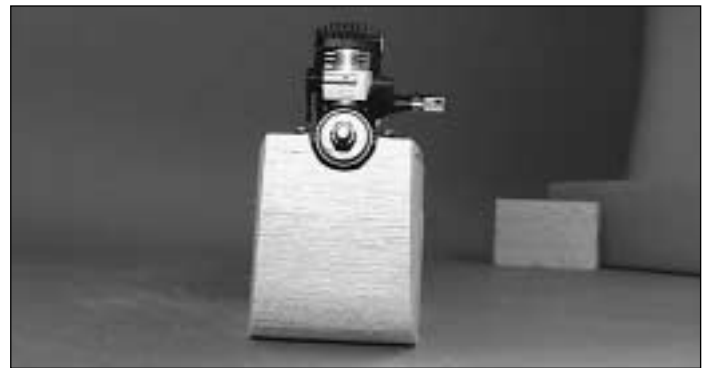

- 16. Position the engine on your mount and trim the front bottom sheeting as necessary so the engine will fit properly on the engine mount.

Mount the Tail



- 1. Sand the rear edge of the fuse flat as shown. Sand the rest of the fuse smooth.

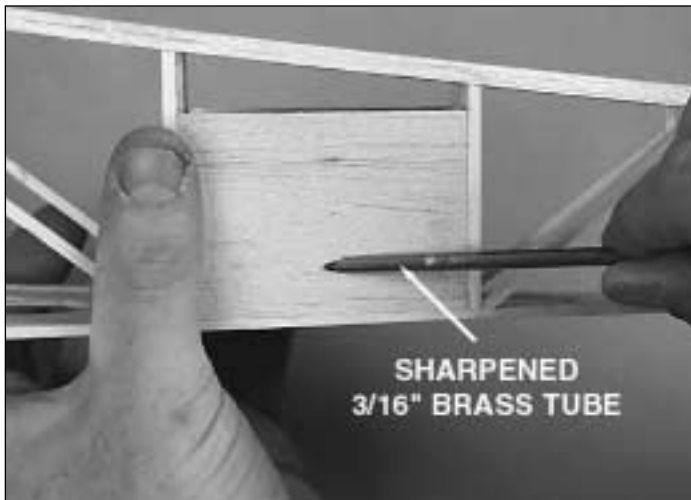

□ 2. Determine the location of the pushrod exit holes from the plan. Use a hobby knife to sharpen one end of a piece of 3/16" (outer diameter) brass tubing, then use this tubing to cut the **pushrod exit holes** (you may use a 3/16" drill bit, but the brass tube makes a much neater cut). **Hint:** You may chuck the brass tube into your drill to aid in cutting these holes.

□ 3. From the 36" long gray outer pushrod tube, cut two 13-1/2" long pieces. Insert the 13-1/2" tubes through the holes you just cut in the fuse side and through formers F5 and F4B so that 1/4" extends past F4B and out the fuse sides.

□ 4. Glue the tubes to the fuse sides, F5 and F4B with thin CA.

□ 5. Cut off the tubes at the exit points and sand them flush with the fuse sides.

□ 6. Mount the wing on the fuse. Trim the wing bolts off 1/8" above the WBP.

□ 7. Turn the plane right side up. Glue the die-cut 3/32 balsa former **F6** vertically in its slots.

□ 8. Accurately measure the trailing edge of the stabilizer and mark the center point.

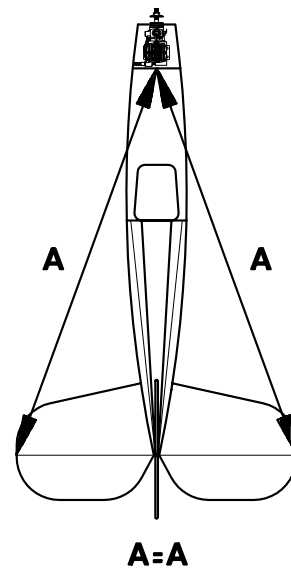
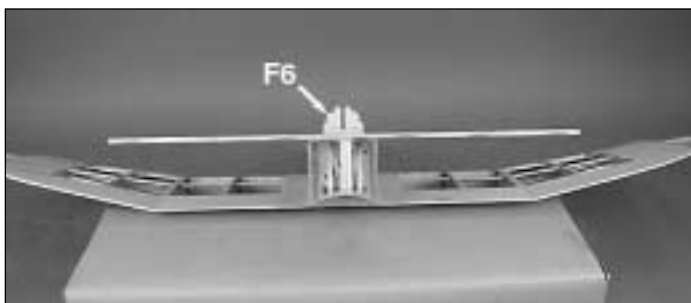

□ 9. Lay the stab in position (the TE should be flush with the TE of the fuse) with the center point lined up with the center of the fuse. Carefully check the stab alignment by standing directly behind the fuselage and "eyeballing" whether or not the stab is parallel to the wing. Sand the stab saddle (**a little at a time!**) until the stab aligns properly with the wing. Also, using your string, measure from the stab tips to a center point on the front of the fuse to make sure the stab is aligned.

□ 10. Using 6-minute epoxy, glue the stab to the fuse. Hold or pin it in proper alignment until the epoxy has fully cured. **Note:** Wipe off any excess epoxy, with a cloth moistened with alcohol, before it sets.



□ 11. Carefully align the fin on the stab. **The fin must be positioned perpendicular to the stab and must line up with the fuselage centerline EXACTLY!** Sand the slot in F6, if necessary to properly align the fin. Glue the fin in place. **Note:** The turtle deck stringers and the turtle deck top will also lock the fin into position.

□ 12. Remove the wing from the fuse.

Build the Front Deck & Turtle Deck

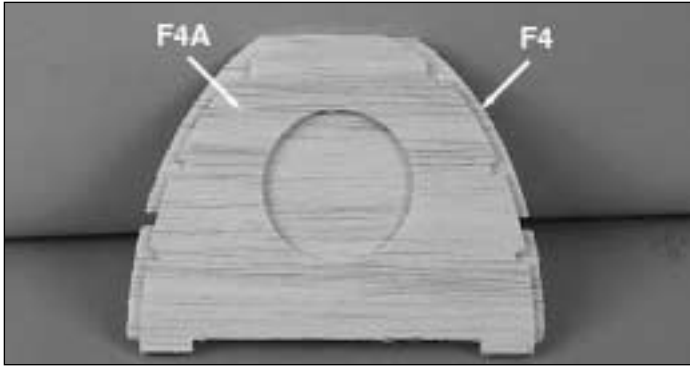

□ 1. Align the tabs on the bottom of the die-cut 3/32" balsa **F4** and **F4A** formers. Laminate the formers with medium CA.

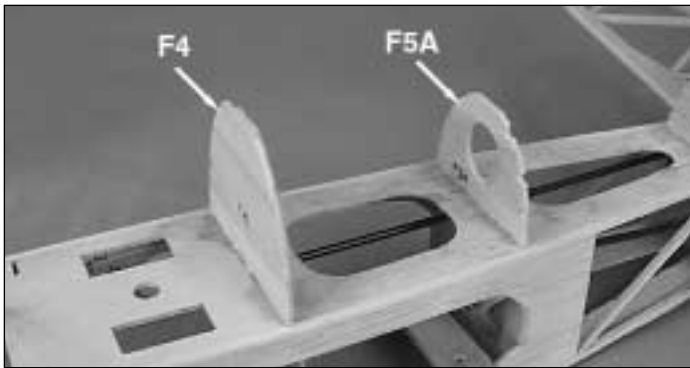

□ 2. With F4A facing the rear of the plane, glue the laminated F4 in place, keeping it perpendicular to the fuse top.

□ 3. Keeping F5A perpendicular to the fuse top, glue it in place.

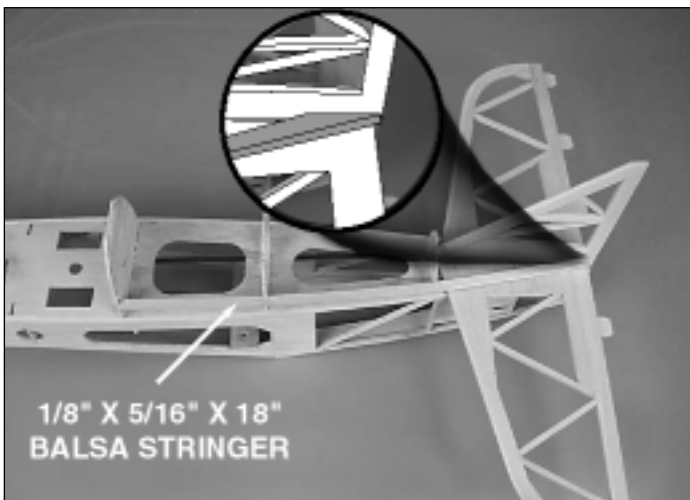

□ 4. Glue a 1/8" x 5/16" x 18" balsa **turtle deck stringer** into the bottom left notches in F4A and F5A. Trim the TE of the stringer so that it comes to a point at the TE of the fin. Glue to F6 and the fin. Repeat this step for the other five turtle deck stringers.

□ 5. Using the full-size template on the plan, make the **turtle deck top** from a 1/4" x 1-3/4" x 18" balsa sheet.

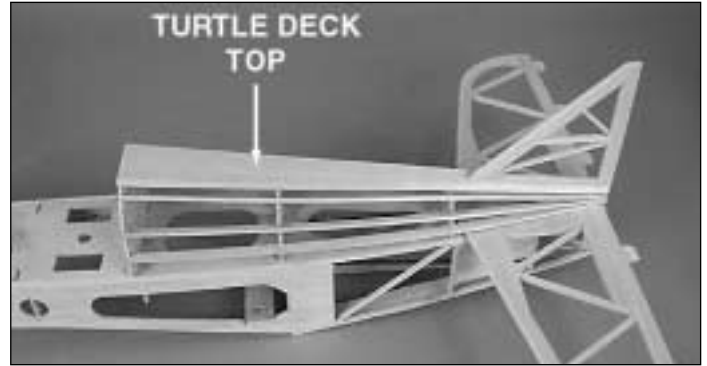

□ 6. Glue the turtle deck top to the turtle deck formers and the fin.

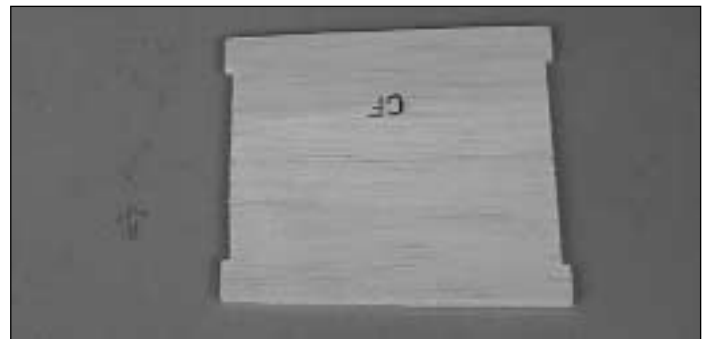

□ 7. Glue the two die-cut 1/8" balsa **cockpit floors** (CF) together, making sure the embossed label is up on one and down on the other.

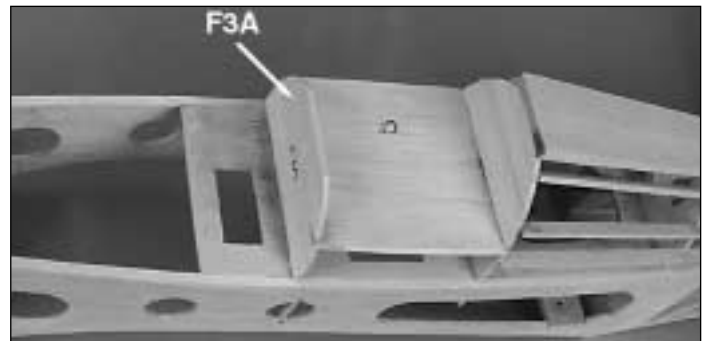

□ 8. Fit and glue the cockpit floor and the die-cut 3/32 balsa former **F3A** in place.

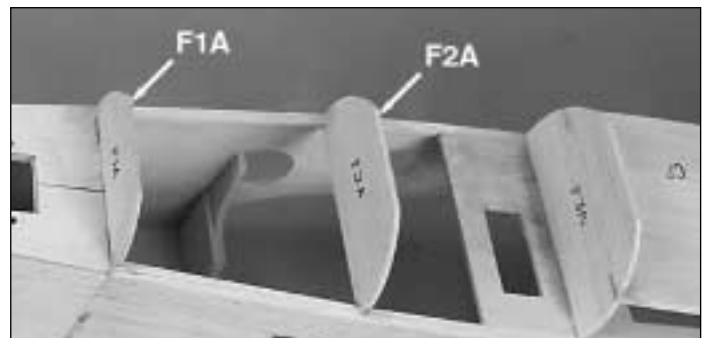

□ 9. Glue the die-cut 1/8" ply former **F1A** in place, keeping it vertical to the engine mount.

□ 10. Glue the die-cut 3/32" balsa former **F2A** in place 4" behind F1A.



□ 11. Cut the 1/8" x 1/4" x 24" balsa stick in half, making two **front deck stringers**. Position each stringer in the notches in F1A, F2A and F3A and flush with F3A. Cut the excess off flush with F1A.

□ 12. Cut a 1/16" x 4" x 30" balsa sheet in half, making two 15" long **front deck sheets**.

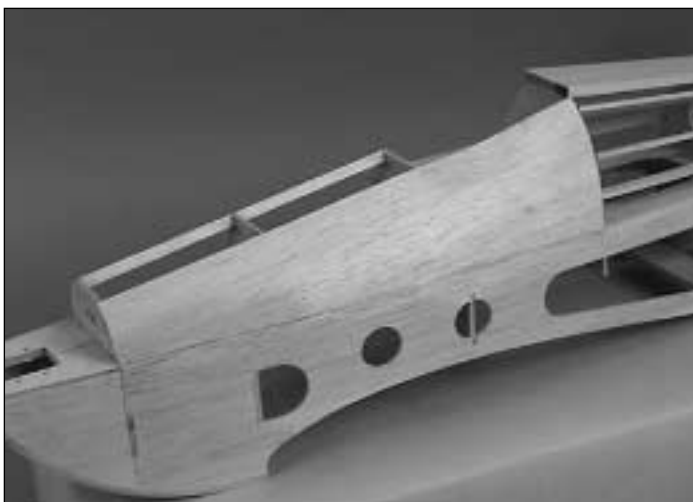

□ □ 13. Align the top of the sheet with the top of the front deck stringer but with 1/4" excess overhanging the top of the stringer. Carefully trim and shape the sheet until satisfied with the fit. **Note:** The grain runs **parallel to the stringer**, not the fuse top.

□ □ 14. Glue the bottom edge of the sheet to the fuse top. Liberally wet the outside of the sheeting by spraying it with an ammonia/water mix. Gently bend the sheet until you can position it in a smooth curve all the way to the stringer. Use medium CA to glue the sheet to the formers and stringer.

□ 15. Repeat steps 13 and 14 for the right side.

□ 16. Sand the front deck sheeting flush with the top of the front deck stringers.

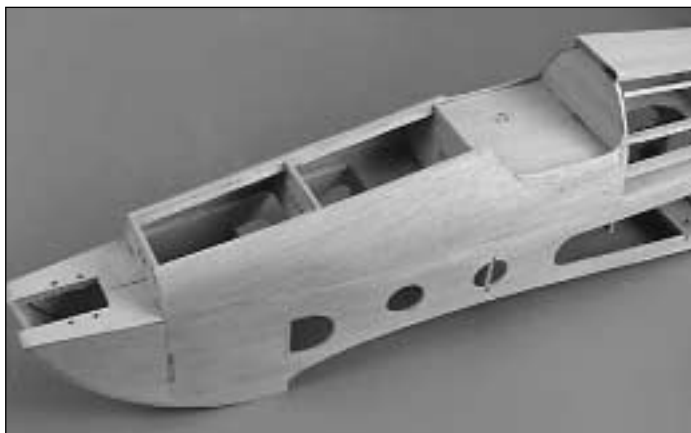

□ 17. Carefully trim the front deck sheet along the cockpit area to have a nice rounded shape as shown in the photo.

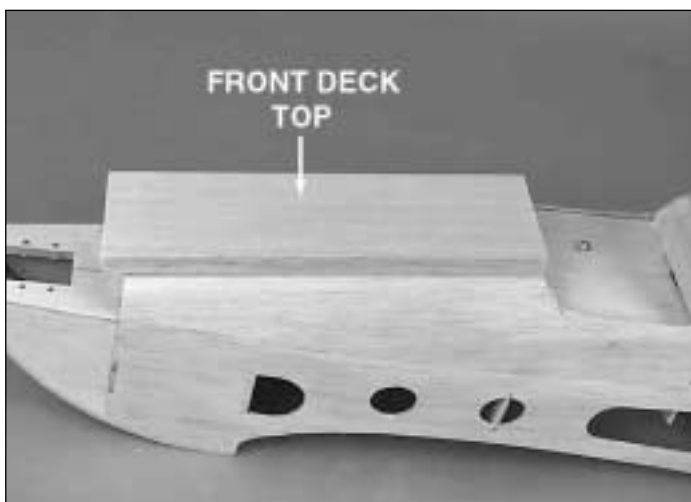

□ 18. Glue the 1/2" x 2-1/2" x 8-3/4" balsa **front deck top** to formers F1A, F2A and F3A and to the front deck stringers, leaving 1/4" overhanging F3A.



□ 19. Carve and sand the front deck top to blend with the rounded shape of the front deck sheet.

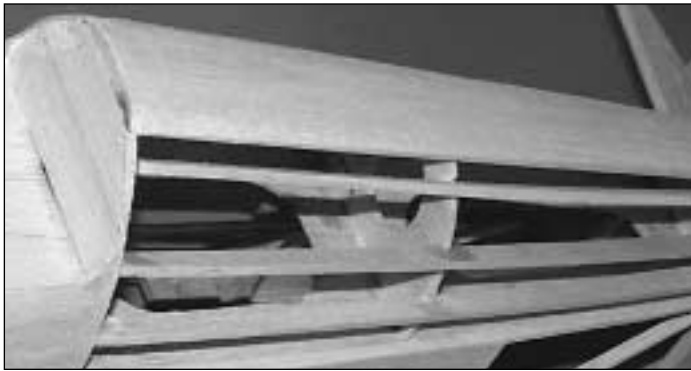

❑ 20. Carve and sand the turtle deck top to blend with the rounded shape of the turtle deck formers. **Note:** The turtle deck top requires less shaping toward the fin.

❑ 21. Using leftover balsa, make fillets around the front of the stab and lower turtle deck stringer.

Wow! Step back and take a good look. Pat yourself on the back! You are completely finished framing your SlowPoke! Nice work.

Install the Servos & Make the Pushrods

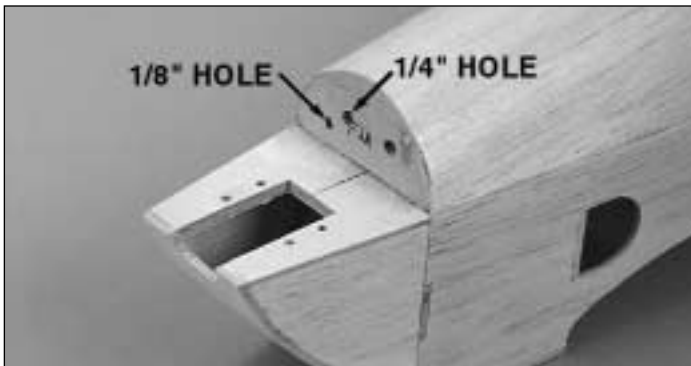

❑ 1. Place the engine on the mount. Mark former F1A for two fuel line holes and one throttle pushrod hole. Remove the engine and drill the two 1/4" fuel line and one 1/8" pushrod holes.

❑ 2. Select the 24" white flex cable outer guide tube for the throttle. Slide it through its hole in F1A until it extends halfway between F2A and F3A. Use medium CA to glue it into F1A. Cut it flush with the outside of F1A.

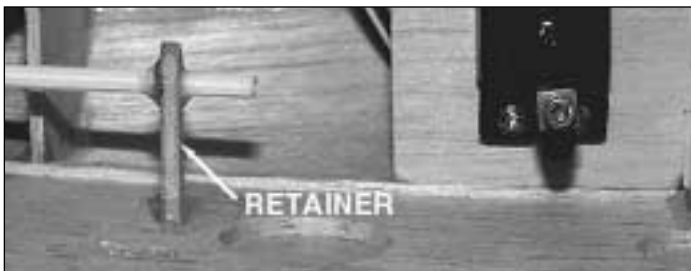

❑ 3. From leftover 1/8" ply, cut a **throttle pushrod retainer**. Glue it in place against the fuse side as shown on the plan.

❑ 4. Mount the throttle servo as shown on the plan. Install a Great Planes Screw-Lock Connector (provided) onto the second hole of the throttle servo arm.

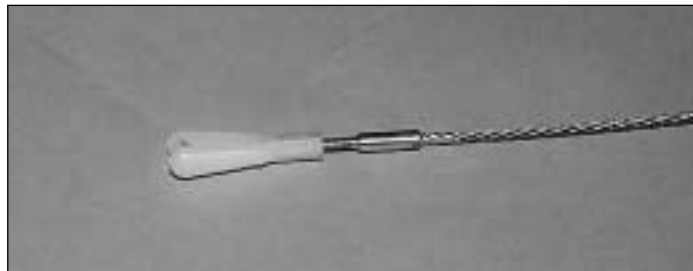

❑ 5. Solder the threaded coupler to the 24" long throttle cable with silver solder. Screw a nylon clevis onto the coupler.

❑ 6. Mount the engine. Slide the throttle cable through the guide tube you installed in step 2. Attach the clevis to the throttle arm on the carb.

❑ 7. Cut the excess cable off 1" behind the Screw-Lock Connector on the throttle servo. Insert the throttle cable through the Screw-Lock Connector.

❑ 8. Cut the 35" pushrod wire (threaded on both ends) into two 17-1/2" long pushrods. Screw a clevis at least 14 turns onto one rod, making the rudder pushrod. Slide the pushrod wire through the rudder pushrod guide tube, which is the guide tube on the left side of the fuselage. Remove the **backing plate** from a nylon **control horn** and connect the horn to the clevis in the outer hole. Fit the rudder to the fin, using the hinges to hold them in place. **DO NOT GLUE.**

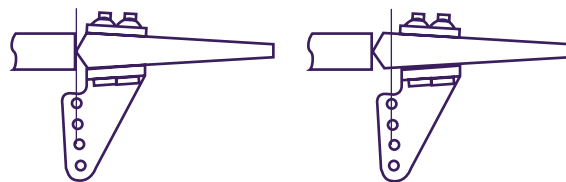

Correct

Incorrect

❑ 9. Position the control horn on the rudder as shown in the sketch and on the plan. Use a ballpoint pen to mark the location of the control horn mounting holes and drill 3/32" holes through the rudder at the marks. Temporarily mount the control horn to the rudder with the backing plate and 2-56 x 5/8" screws.

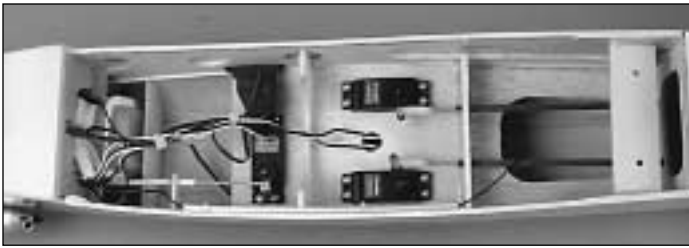

Reference this photo for the next 5 steps.

- 10. Position the rudder servo in the left side of the servo tray as shown on the plan. Mount the servo.

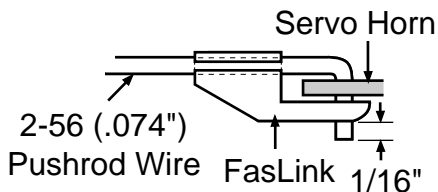

- 11. Center the rudder and position the servo arm perpendicular to the servo case. Mark the pushrod where it crosses the servo arm. Bend the pushrod and connect it to the servo arm with a Faslink™. Trim the excess wire that protrudes past the Faslink. Unhook the clevis and temporarily remove the rudder.

- 12. Fit the elevators to the stabilizer, using hinges to hold it in place. **DO NOT GLUE** the hinges in position at this time.

- 13. Screw a clevis onto the elevator pushrod wire at least 14 turns. Slide the pushrod through the elevator pushrod guide tube on the left side of the fuselage. Position and temporarily mount the elevator control horn to the right elevator as you did with the rudder control horn.

- 14. Install the elevator servo as shown on the plan. Position the servo arm square with the servo case and set the elevators to neutral. Mark the pushrod where it crosses the servo arm, bend it and connect it to the servo arm with a Faslink. Trim the excess wire above the Faslink.

- 15. Mark the location of the **tail gear wire** on the rudder and the nylon tail gear bearing on the fuselage.

- 16. Remove the rudder and elevators from the model. Using a pen, draw lines around the control horns and remove the control horns. Poke approximately a dozen holes in each surface's control horn location with the tip of a hobby knife, or T-pin. Remove the hinges from each surface, then use thin CA to harden the wood inside the lines you drew where the control horns attach.

- 17. Drill a 7/64" hole 5/8" deep in the leading edge of the rudder at the mark you made for the tail gear wire. Test fit the tail gear wire in the rudder. Cut a slot in the trailing edge of the fuse at the marks you made for the nylon tail gear bearing. Without using any glue, test fit the rudder to the fin with the tail gear wire. When satisfied with the fit, remove and set it aside.

PREPARE FOR COVERING

- 1. Remove all the pushrods and remove the hinges and control horns from the elevators and rudder. Remove the engine and any other hardware you may have installed.

- 2. Most of the model should be rough-sanded by now, with all the tabs and rough edges sanded even. Fill all dents, seams, low spots and notches with HobbyLite™ Balsa Colored Filler.

- 3. After the filler has dried, use progressively finer grades of sandpaper to even all the edges and seams and smooth all surfaces. Remove all balsa dust from the model with compressed air or a vacuum with a brush followed by a tack cloth.

COVER THE MODEL WITH MONOKOTE FILM

Before you cover the fuselage, first apply 1/4" wide strips of MonoKote film in the corners of the stab and fuse and the fin and the fuse, then proceed to cover the fin and stab with pre-cut pieces that meet in the corners and overlap the 1/4" strips. **Never cut the covering on the stab and fin after it has been applied except around the leading and trailing edges and at the tips.** Modelers who cut covering on top of the wood structure may cut through the covering and into the stab or fin. This will weaken the structure to a point where it may fail during flight.

FUELPROOF THE MODEL

After the model is covered, you must fuelproof the inside of the front bottom sheeting and cockpit. You may do so with fuelproof model paint, 30-minute epoxy thinned with alcohol, or finishing resin.

INSTALL THE WINDSHIELD

- 1. Using the template on the plan as a guide, cut a windshield from the supplied butyrate sheet.

- 2. Use canopy glue to adhere the windshield to the covering in the position shown on the plan. **Hint:** A piece of pinstripe tape along the contact area makes an attractive seam.

INSTALL THE TANK

1. Assemble your Great Planes 4 oz. fuel tank (not included). Attach a 6" piece of fuel tubing to the top nipple, which will attach to the muffler pressure tap. Assemble and install the tank cap. Attach a second piece of 6" fuel tubing to the main nipple in the center of the tank cap, which will attach to the carburetor.

2. Feed the fuel lines through F1A. **Hint:** Mark on F1A which line came from the top nipple and goes to the muffler and which line came from the main nipple and goes to your carb.

3. Install the fuel tank. Cushion it from vibration and prevent it from moving by surrounding the tank on all sides (and front) with foam rubber. Leave a few inches of extra fuel tubing in front of F1A. Use leftover ply to support the tank.

INSTALL THE LANDING GEAR

1. Cut a slot in the covering down the center of each landing gear rail.



2. Fit one prebent wire landing gear wire into each gear rail.

3. Using two nylon gear retainers and four #2x3/8" sheet metal screws, secure each gear wire as shown in the photo.

4. Using four 5/32" wheel collars (not supplied), install your 3" wheels.

FINAL HOOKUPS & CHECKS

Attach the Control Surfaces

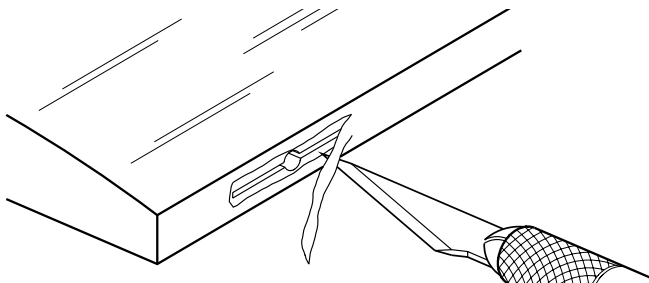

1. Start with the elevators and stab. Cut the covering from the hinge slots—don't just *slit* the covering but remove a small strip the size of the hinge slot.

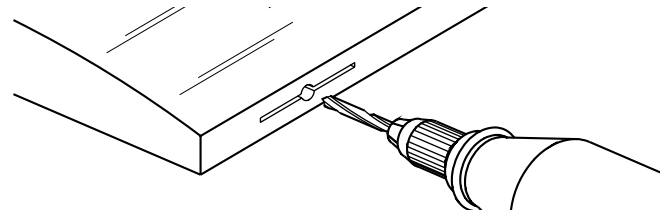

2. Drill a 3/32" hole 1/2" deep in the center of each hinge slot. A high speed Dremel Tool works best for this. If you use a regular drill, clean out the hinge slots with a #11 blade.

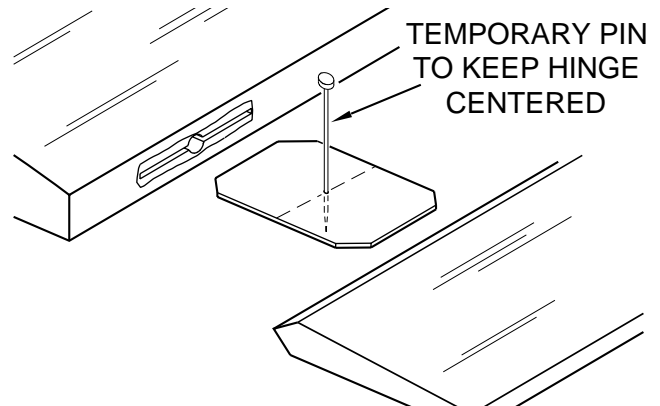

3. Without using any glue, fit the hinges in the elevators or stab. **Do not glue the hinges yet.** As you join the elevators to the stab, confirm that the hinges are equally inserted in the elevators and the stab. Insert a small pin in the center of the hinges to keep them centered.

ASSEMBLE, THEN APPLY 6 DROPS OF THIN CA TO CENTER OF HINGE, ON BOTH SIDES

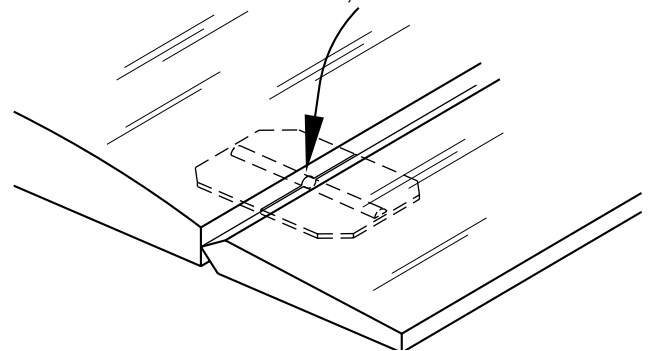

THE CA WICKS ALONG THE "TUNNELS" TO THE ENTIRE HINGE SURFACE

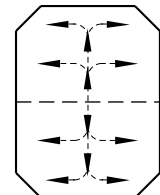

4. Remove the pin and add 6 drops of thin CA to the center of all the hinges on both the top and the bottom.

Do not use accelerator on any of the hinges. Do not glue the hinges with anything but thin CA and do not attempt to glue one half of the hinge at a time with medium or thick CA. They will not be properly secured and the controls could separate while the model is in flight.

□ 5. Prepare the hinge slots for the rudder as you did the elevators. Join the rudder to the fin with the hinges and use 30-minute epoxy to simultaneously glue the tail gear wire in the rudder and the tail gear bearing in the fuse. **Do not glue the nylon bearing to the rudder.** Glue the hinges in position with thin CA. **NOTE:** Petroleum jelly on the areas where the tail gear bearing contacts the wire will ensure that it does not glue to the tail gear wire or rudder.

Install the Hardware

- 1. Install the engine and hook up the fuel lines and throttle pushrod.
- 2. Install a 1-1/4" tail wheel with a 3/32" wheel collar.

Final Servo & Receiver Installation

- 1. Reattach all control horns.
- 2. With the model inverted in the stand and using the plan as a reference, locate the pushrod tube exits on the model. Trim the covering from these openings. Reinstall the pushrods and hook up the control surfaces.
- 3. Wrap the receiver in 1/4" (or thicker) foam. Wrap the battery in 1/4" foam. Temporarily position them as shown on the plan. **Note:** You will use these components to help set your C.G.

Set the Control Throws

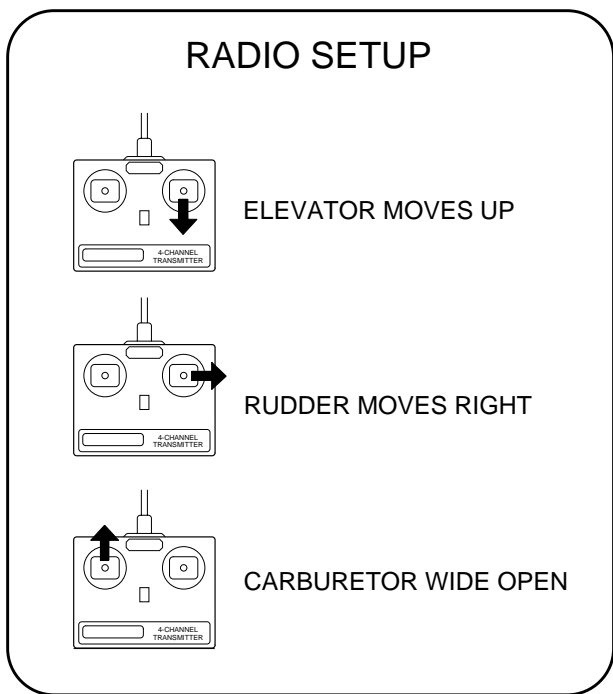

We recommend the following control surface throws:
NOTE: The throws are measured at the **widest part** of the elevators and rudder. Adjust the position of the pushrods at the control/servo horns to control the amount of throw. You may also use the ATV's if the transmitter has them but the mechanical linkages should still be set so the ATV's are near 100% for maximum servo power and the best servo resolution (smoothest, most proportional movement). Be sure to confirm your surfaces move the correct direction.

	High Rate	Low Rate
ELEVATOR:	5/8" up 5/8" down	1/2" up 1/2" down
RUDDER:	2" left and right	

NOTE: If the radio does not have dual rates, then set the control surfaces to move **between** the high rate and low rate throws.

NOTE: The balance and control throws for the SlowPoke have been extensively tested. We are confident that they represent the settings at which the SlowPoke flies best. Please set up your model to the specifications listed above. If, after you become comfortable with your SlowPoke, you would like to adjust the throws to suit your tastes, that's fine. Too much throw can force the plane into a stall, so remember, "more is not better."

BALANCE YOUR MODEL

Balance the Model Laterally

Do not confuse this procedure with "checking the C.G.", which will be the next step in balancing your model.

A model which is not laterally balanced properly may exhibit a variety of unpleasant tendencies, such as uncharacteristic tip stalls. This aircraft, when balanced properly, has NO such bad tendencies. Be sure to check the lateral balance carefully as described to help ensure that the model exhibits the same handling qualities of our prototypes.

- 1. With the wing level and attached to the model (and the engine and muffler installed), lift the model by the propeller shaft and the fin several times. Notice which wing tip drops. **Hint:** You may need assistance to perform this step.
- 2. The wing which consistently drops is the heavy side. Balance the model by adding weight to the other tip.

Balance the Model Fore & Aft (CG)

NOTE: This section is VERY important and must NOT be omitted! A model that is not properly balanced will be unstable and possibly unflyable.

- 1. Mount the receiver switch in a convenient location that will not interfere with the servos and pushrods inside the fuselage.

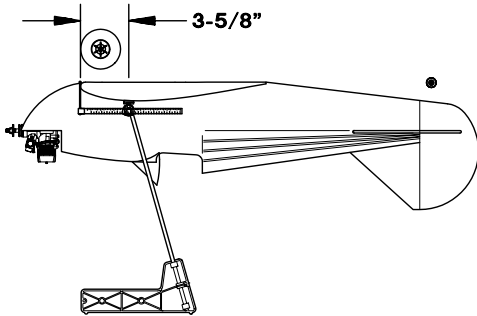

- 2. Accurately mark the balance point on the **top** of the wing on both sides of the fuselage. Use thin strips of tape or a felt tip pen to make the marks. The balance point (**CG**) is located **3-5/8" back from the leading edge where the wing meets the fuse** as shown in the sketch and on the wing plan. **Hint:** Reference the full size wing plan to help you locate the proper balance point. This is the balance point at which the model should balance for your first flights. After initial trim flights and when you become more acquainted with your SlowPoke, you may wish to experiment by shifting the balance up to **5/16" forward or back** to change the flying characteristics. Moving the balance **forward** may improve the smoothness and stability but the model may then require more speed for takeoff and make it more difficult to slow for landing. Moving the balance **aft** makes the model **more agile**. In any case, **please start at the location we recommend and do not at any time balance your model outside the recommended range.**

- 3. With the wing attached to the fuselage, all parts of the model installed (ready to fly) and an **empty** fuel tank, hold the model upside-down with the stabilizer level. Lift the model at the balance point. If the **tail** drops when you lift, the model is "tail heavy" and you must add weight* to the nose to balance the model. If the **nose** drops, it is "nose heavy" and you must add weight* to the tail to balance the model. **NOTE:** Nose weight may be easily installed by using a "spinner weight" or gluing lead weights to the firewall. Tail weight may be added by using Great Planes (GPMQ4485) "stick-on" lead weights.

- 4. Permanently mount your receiver and battery.

** If possible, first attempt to balance the model by changing the position of the receiver battery and receiver. If you are unable to obtain good balance by doing so, then it will be necessary to add weight to the nose or tail to achieve the proper balance point.*

PREFLIGHT

At this time check all connections including servo arm screws, Faslinks, clevises and servo wires. Make sure you have installed the **silicone retainers** on all the clevises.

Charge the Batteries

Follow the battery charging procedures in your radio instruction manual. You should **always** charge the transmitter and receiver batteries the night before you go flying and at other times as recommended by the radio manufacturer.

Balance the Propeller

Balance the propellers carefully before flying. An unbalanced prop is the single most significant cause of vibration. Not only may engine mounting screws vibrate out, possibly with disastrous effect, but vibration may also damage the radio receiver and battery. Vibration may cause the fuel to foam, which will, in turn, cause your engine to run lean or quit.



We use a Top Flite Precision Magnetic Prop Balancer in the workshop and keep a Great Planes Fingertip Balancer in our flight box.

Find a Safe Place to Fly

Since you have chosen the SlowPoke we assume that you are an experienced modeler. Therefore, you should already know about AMA chartered flying fields and other safe places to fly. If for some reason you are a relatively inexperienced modeler and have not been informed, we strongly suggest that the best place to fly is an AMA chartered club field. Ask the AMA or your local hobby shop dealer if there is a club in your area and join. Club fields are set up for R/C flying and that makes your outing safer and more enjoyable. The AMA address and telephone number is in the front of this manual.

If a club and flying site are not available, find a large, grassy area at least 6 miles away from houses, buildings and streets and any other R/C radio operation like R/C boats and R/C cars. A schoolyard may look inviting but is too close to people, power lines and possible radio interference.

Ground Check the Model

If you are not thoroughly familiar with the operation of R/C models, ask an experienced modeler to inspect your radio installation and confirm that all the control surfaces respond correctly to transmitter inputs. The engine operation must also be checked by confirming that the engine idles reliably and transitions smoothly and rapidly to full power and maintains full power indefinitely. The engine must be “broken-in” on the ground by running it for at least two tanks of fuel. **Follow the engine manufacturer’s recommendations for break-in.** Make sure all screws remain tight, that the hinges are secure and that the prop is on tight.

Range Check Your Radio

Whenever you go to the flying field, check the operational range of the radio before the first flight of the day. First, make sure no one else is on your frequency (channel). With your transmitter antenna collapsed and the receiver and transmitter on, you should be able to walk at least 100 feet away from the model and still have control. While you work the controls have a helper stand by your model and tell you what the control surfaces are doing.

Repeat this test **with the engine running** at various speeds with a helper holding the model. If the control surfaces are not always responding correctly, **do not fly!** Find and correct the problem first. Look for loose servo connections or corrosion, loose bolts that may cause vibration, a defective on/off switch, low battery voltage or a defective cell, a damaged receiver antenna, or a receiver crystal that may have been damaged from a previous crash.

Engine Safety Precautions

NOTE: Failure to follow these safety precautions may result in severe injury to yourself and others.

Keep all engine fuel in a safe place, away from high heat, sparks or flames, as fuel is very flammable. Do not smoke near the engine or fuel. Remember that the engine exhaust gives off a great deal of deadly carbon monoxide. **Do not run the engine in a closed room or garage.** Get help from an experienced pilot when learning to operate engines.

Use safety glasses when starting or running engines.

Do not run the engine in an area of loose gravel or sand; the propeller may throw such material in your face or eyes.

Keep your face and body as well as all spectators away from the plane of rotation of the propeller as you start and run the engine.

Keep ALL items away from the prop, including: radio neck straps, loose clothing, shirt sleeves, ties, scarves, long hair or loose objects such as pencils, screw drivers that may fall out of shirt or jacket pockets into the prop.

When using a “chicken stick” or electric starter, follow instructions supplied with the starter or stick. Make certain the glow plug clip or connector is secure so that it will not pop off or otherwise get into the running propeller.

Make all engine adjustments from **behind** the rotating propeller.

The engine gets hot! Do not touch it during or after operation. Make sure fuel lines are in good condition so fuel will not leak onto a hot engine causing a fire.

To stop the engine, cut off the fuel supply by closing off the fuel line or follow the engine manufacturer’s recommendations. Do not use hands, fingers or any body part to try to stop the engine. Do not throw anything into the prop of a running engine.

AMA Safety Code (excerpts)

Read and abide by the following Academy of Model Aeronautics Official Safety Code:

General

1. I will not fly my model aircraft in sanctioned events, air shows, or model flying demonstrations until it has been proven to be airworthy by having been previously successfully flight tested.
2. I will not fly my model aircraft higher than approximately 400 feet within 3 miles of an airport without notifying the airport operator. I will give right of way to and avoid flying in the proximity of full scale aircraft. Where necessary an observer shall be used to supervise flying to avoid having models fly in the proximity of full scale aircraft.
3. Where established, I will abide by the safety rules for the flying site I use and I will not willfully and deliberately fly my models in a careless, reckless and/or dangerous manner.
7. I will not fly my model unless it is identified with my name and address or AMA number, on or in the model.
9. I will not operate models with pyrotechnics (any device that explodes, burns, or propels a projectile of any kind)

Radio control

1. I will have completed a successful radio equipment ground check before the first flight of a new or repaired model.
2. I will not fly my model aircraft in the presence of spectators until I become a qualified flier, unless assisted by an experienced helper.
3. I will perform my initial turn after takeoff away from the pit or spectator areas and I will not thereafter fly over pit or spectator areas, unless beyond my control.
4. I will operate my model using only radio control frequencies currently allowed by the Federal Communications Commission.

FLYING

CAUTION (THIS APPLIES TO ALL R/C AIRPLANES): If, while flying, you notice any unusual sounds, such as a low-pitched “buzz”, this may indicate control surface “flutter”. Because flutter can quickly destroy components of the airplane, any time you detect flutter you must **immediately** cut the throttle and land the airplane! Check all servo grommets for deterioration (this may indicate which surface fluttered) and make sure all pushrod linkages are slop-free. If it fluttered once, it will probably flutter again under similar circumstances unless you can eliminate the slop or flexing in the linkages. Here are some things which can result in flutter: Excessive hinge gap; Not mounting control horns solidly; Sloppy fit of clevis pin in horn; Elasticity present in flexible plastic pushrods; Side-play of pushrod in guide tube caused by tight bends; Sloppy fit of Z-bend in servo arm; Insufficient glue used when gluing in the elevator joiner wire or aileron torque rod; Excessive flexing of aileron, caused by using too soft balsa; Excessive “play” or “backlash” in servo gears; and Insecure servo mounting.

The SlowPoke does not possess the self-recovery characteristics of a primary R/C trainer and should only be flown by experienced RC pilots. Have fun!

Takeoff

Takeoff on “high” rates if you have dual rates on your transmitter. For all models it is good practice to gain as much speed as the length of the runway will permit before lifting off. This will give you a safety margin in case the engine quits. When you initially advance the throttle and the tail begins to lift, the SlowPoke will begin to turn to the left (due to the torque of the engine—a characteristic of all taildraggers). Be prepared for this by applying sufficient

right rudder to keep the SlowPoke running straight down the middle of the runway (or flying field). The left turning tendency will decrease as the plane picks up speed. Be sure to allow the tail to rise off the ground before lifting the model into the air. Depending on the surface you are taking off from, you will need to apply little or no up elevator until flying speed is reached. Don't hold the tail on the ground with too much up elevator, as the SlowPoke will become airborne prematurely and may stall. When the plane has gained enough flying speed to safely lift off, gradually and smoothly apply up elevator and allow the model to climb at a shallow angle (do not yank the model off the ground into a steep climb!)

Flight

We recommend that you take it easy with your SlowPoke for the first several flights, gradually “getting acquainted” with this Sunday flier as your engine gets fully broken-in. If you feel as though you have your hands full, keep this one thing in mind: **pull back on the throttle stick to slow the model down**. This will make everything happen a little slower and allow yourself time to think and react. Add and practice one maneuver at a time, learning how the SlowPoke behaves in each. The high rates are primarily for take offs and landings. For smooth flying and normal maneuvers, use the low rate settings as listed on page 28.

Sometime well before it's time to land you should climb your SlowPoke to a safe altitude and cut the throttle to an idle and check out the model's low speed characteristics. Do this a few times so you know what to expect upon landing.

Landing

When it's time to land, fly a normal landing pattern and approach. Keep a few clicks of power on until you are over the runway threshold. For the first few landings, plan to land slightly faster than stall speed and on the main wheels, as this is the easiest way to land your SlowPoke. Later, with a little practice you will find you can make slow 3-point landings.

Have a ball! But always remember to think about your next move and plan each maneuver before you do it. Impulsively “jamming the sticks” without any thought is what gets most fliers in trouble rather than lack of flying skill.

TWO-VIEW

