

BUILDING and FLYING the

S. T. F. A

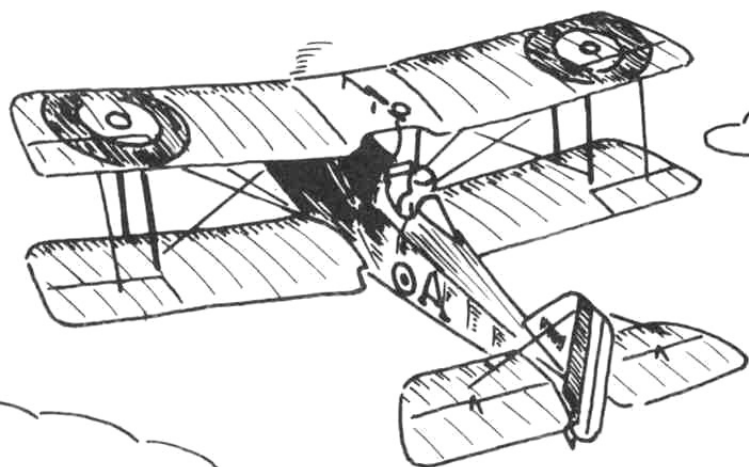

by
Dave Platt

Product Support
(Do Not Remove From Department)



TOP FLITE MODELS INC.

2635-47 SOUTH WABASH AVENUE • CHICAGO, ILLINOIS 60616

Congratulations! You now own the most accurate R/C scale kit ever produced.

We at Top Flite are sure that you will find this model among the most pleasant-to-build, inspiring to look at, and exciting to fly that you have constructed.

It is honest to point out, however, that while this model is no more difficult—in fact is simpler than most comparable models—to make, R/C Scale models generally are not for the newcomer to this hobby. Some previous modeling experience and careful attention to craftsmanship are necessary. Even the "old hand" will do well to study the instructions and hints in this booklet.

It is our aim to have you say: "This is the finest model I have ever made."

TOP FLITE MODELS, INC.

INTRODUCTION

The S. E. 5A has always been a modeler's favorite. Among all airplanes, and certainly of those which were born and flew to fame and distinction during World War I, the S. E. 5 was one of the best and most attractive. Not the least of the reasons for its great appeal to modelers is the great **suitability** of its design as a flying model. Let's explain this.

To make a successful flying model, without changes to the outline or sections which would destroy its essential character, we need the following features:

- a. The nose length of the airplane ought to be enough to guarantee a good balance without adding large amounts of weight in the front end;
- b. The tail surfaces (stabilizer and fin) control the stability of a model to a large extent. If the model is more stable in flight, it will be easier and safer to fly. We require that the stab and fin be big enough to insure good stability without enlargement.
- c. The airplane should be fairly simple in design to eliminate building complexities.
- d. Size is important too. For reasons of transportation and ability to fly in a reasonable wind, experience has shown that the wing span of the model (for a .40 - .60 engine) should be in the 50 - 60" range. In order to eliminate headaches in small and fussy details, a scale of 2"=1' is found very suitable. This means our subject real plane needs to be 24' - 30' wing span.

How does the S. E. 5A shape up?

First, it has just about as long a nose as is found in fighter airplanes of the period. Balance will not be a problem—a tail-heavy S. E. 5 would be difficult to come up with.

Secondly, the areas of the tail feathers have been found to give excellent stability just as they are. A model of the S. E. 5A will be a stable and safe model—so stable, in fact, that it can be flown very successfully with single-channel R/C equipment controlling only the rudder.

Thirdly, the S. E. 5A has clean, functional and straightforward outlines and shapes that are easy to model.

Lastly, the wing span of 26' 7-1/2" gives our 2"=1' model an ideal span of a bit over 53". This size model will fit into most cars without disassembly, saving a lot of trouble.

So we see that our requirements are amply met in these respects. Some other planes are just as suitable—but lack one final important requirement. They are obscure or little-known subjects that somehow never rang the bell. The S. E. 5A, on the other hand, is a glorious and immortal plane that every scale modeler has made or hopes to make some day.

BEFORE YOU START—READ THIS!

These instructions have been carefully developed after building several prototype models. We urge you, in your own interest, not to ignore them. Our aim is to insure that the model goes together in a reasonably quick time and without annoying snags.

Regardless of previous modeling experience follow the directions carefully, checking them off as you go.

Notice the instructions often call for some items to be started before others are complete. This is to allow time for important glue joints to dry properly, yet not hold up building progress. Also, in order to help modelers of less experience, we have tended to the easier jobs first, leaving those requiring more care until later as skill increases.

Do **not** separate parts from die cut sheets until you need them! This will save loss or breakage of some of the small or delicate pieces.

We are often asked by less-experienced modelers which glues are best for model construction. The answer to this depends upon the particular job. However, this is our normal recommendation: for all hardwood-to-hardwood or hardwood-to-balsa joints use white wood glue. "Titebond" is especially good, as it dries faster than other white glues and is very strong. For balsa-to-balsa joints, regular balsa-wood cements are ample for the job, although white glue can be used here too. Whichever type you use, remember that excess glue is no substitute for a well-fitting joint. Use a minimum of glue at all times, and wipe off excess glue that squeezes out of joints before it sets hard; when set it is difficult to remove, but if not removed it will spoil the covering job.

For joints involving flexible items, like foam rubber R/C equipment packing, "contact cement" is the only suitable adhesive: this should not be used in construction, however, because it is not sufficiently strong and is very hard to sand down properly.

One final word to newcomers to the hobby or modelers of limited experience. Join a club! (You can write to the Academy of Model Aeronautics, 1239 Vermont Avenue, N. W., Washington, D. C. 20005, for the address of your nearest Club Secretary.) Here you will find indispensable guidance and help from experienced and friendly fellow-modelers, should you encounter any small problem in building or flying this model. We at Top Flite will do our best to insure your success, but it is fair to say that nothing can replace personal help or demonstration from a good modeler.

ASSEMBLY SEQUENCE

1. Take Plan Sheet 1 (wings) and cut it into sections along the dotted lines. Using scotch tape, join up the appropriate sections to make two complete wing plans: be careful to join up the sections correctly and see that all lines mate perfectly along the joins.
2. Take Plan Sheet 2 and cut along the dotted lines to separate the stabilizer and fuselage plan views.
3. If possible, spread out the plan sections containing the stab and fuselage plan view on your working surface, so that work can be done simultaneously at either one of them. Note that the plans are waxed to prevent the built assemblies from becoming glued to the plans.

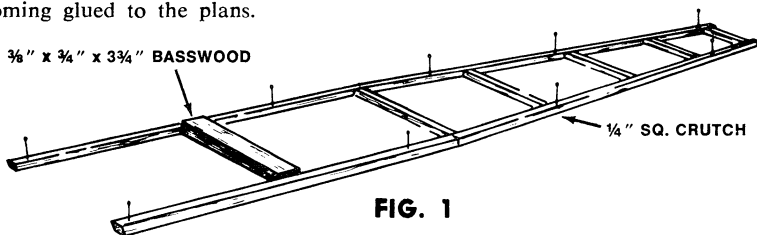

FIG. 1

4. The first item to build is the fuselage "crutch." See Figure 1. Construct directly over the plan from $\frac{1}{4}''$ square. Glue in the $\frac{3}{8}'' \times \frac{3}{4}'' \times 3\frac{3}{4}''$ hardwood block. Make 2 of each cross-brace; one set to use now and a set that will be used later.
5. Study Figure 2. Glue $\frac{1}{2}'' \times \frac{1}{2}'' \times 6\frac{5}{8}''$ maple motor-plate mounts on F-1 sides in printed positions. Make a left and a right side. Transfer the printed marks for mounts on F-1 with pins for the (right) fuselage side — See Figure 2.

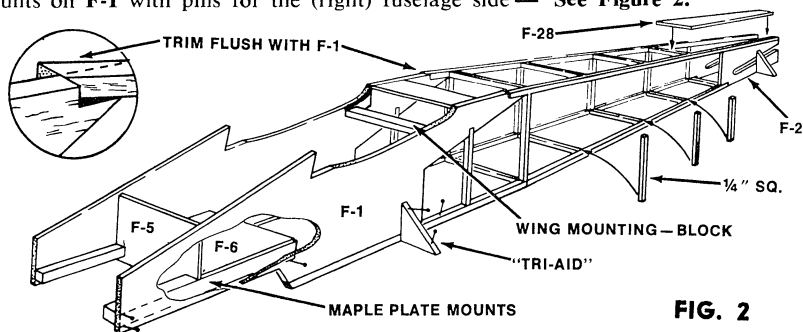

FIG. 2

After removing any pins from the crutch that will get in the way, glue side pieces F-1 and F-2 to the crutch. Use the "TRI-AIDS" provided to insure the sides are truly vertical

Glue the 1/4" sq. bottom longerons to F-1 and F-2, followed by F-28 and the vertical spacers Use the side view of the fuselage for the correct lengths

The previously-cut horizontal cross-braces are glued in next, also F-1A's, F-18 and F-5 (ply) Glue in F-6 (ply) and the other 3/8" x 3/4" x 3-3/4" hardwood block for wing mounting (Special note if it is intended to install a Top Flite 2" scale pilot, this hardwood block should be glued in only lightly at this time—later it should be removed to allow the pilot to be slid up into place from the wing opening After the pilot is installed, the wing mount block can be glued firmly in place.)

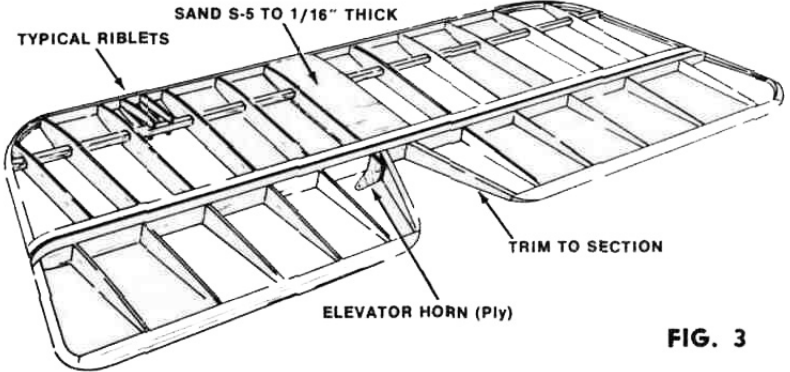

FIG. 3

6. While this assembly is drying start on the stabilizer See Figure 3. Pin down the 1/4" x 1/2" stab trailing edge (T E) to the plan Cut a piece of 1/4" sq to length for the spar and thread ribs S-1, S-2 and S-3 onto the spar in correct order Do not glue the joints yet. Glue and pin the ribs to the T E Note that the center two ribs must be shimmed up 1/16" to bring the ribs centered on the TE

Laminate the two S-4 parts that make each tip Cut leading-edge (LE) to length from 1/4" sq and glue to all ribs, with 1/8" shim under it Now glue all rib-to-spar joints, and glue tips S-4 in place Sheet over center two ribs with piece S-5. Set aside to dry

7 Remove fuselage assembly from board and turn right-side up At this time you can put aside the fuselage plan-view as no more fuselage construction will be done on the board Sand fuselage, trimming bottom longeron at F-1. See Figure 4. Glue two F-3A pieces together and glue both to F-4. Glue F-11 to F-11A and F-14 to F-14A. Lay these items aside to dry.

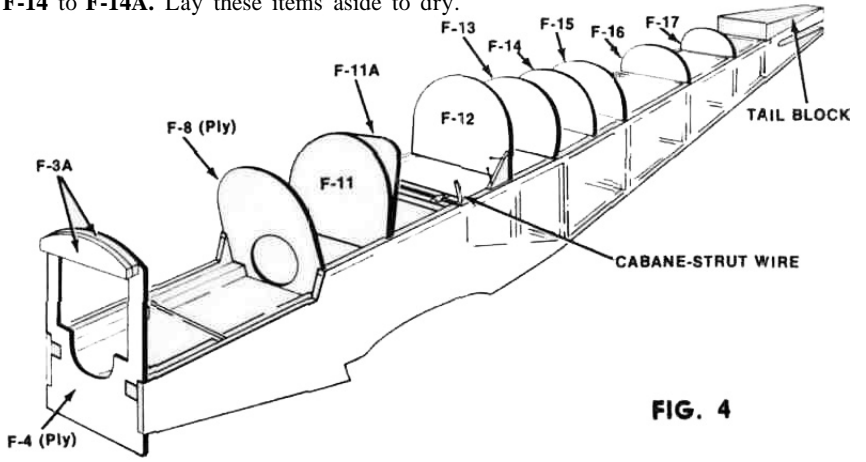

FIG. 4

File notches into the rear cabane-strut wire and attach to the hardwood blocks in the crutch, using metal clips and woodscrews provided. Glue the shaped tail block in position on the fuselage, also formers F-17, F-16, F-15, F-14 and 14A, F-13, F-11 and 11A, F-8 and F-4. Formers 8, 11 and 13 must be glued at correct angles (see side view). Take care here, as the fit of the cut panels F-23 to F-27 depends on the accuracy of the angles on the formers.

8. Remove stabilizer from plan. Turn upside down and glue second S-5 in place. Pin down 1/4" x 1/2" elevator L. E. Glue laminated E-2's together for tips. Pin 1/8" x 3/8" T.E.'s in position, shim underneath 1/4" at rear edge. Glue all E-1 ribs and E-2 tips in place, also center ribs from 1/4" x 1/2" cut to length.

9. Sand the stabilizer smooth, rounding off the L. E. and tips. The small riblets are simply cut from 1/16" x 1/8" and glued in place, then sanded to conform to section when dry. These riblets are marked "optional" on the plan, since they could be omitted without affecting the strength of the stab. However, for the sake of the scale appearance it is worth taking the small extra time to incorporate them.

10. When elevators have dried, remove from plan and sand smooth like the stab. Glue in 1/16" ply elevator horn E-3. The stab and elevator can now be hinged together using the material provided cut to length — see plan for positions. Glue a small piece of 1/16" scrap sheet alongside the elevator horn to support the covering. The stab is now finished.

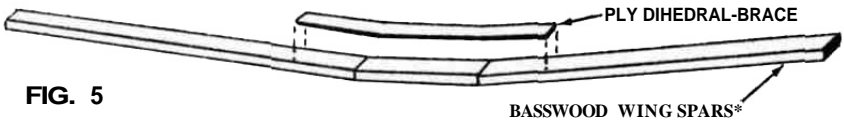

FIG. 5

11. Make up the wing spars (see Figure 5) as follows: Take the 1/4" x 3/8" and 1/4" x 1/4" basswood spars and cut two 8" lengths of each size. Glue these in the center of ply parts D-1 and D-2. Then glue long spars to each side at the same angle as the ply parts, over the plan sheet #1. Construct four such spars: two from 1/4" x 3/8" and two from 1/4" x 1/4". It will help to pin these to the board right next to each other while they dry, so as to have identical angles on all sets.

12. Glue ply F-7 between fuselage sides, lower front. The two holes are for excess engine oil to drain away from the engine bay, and should be positioned just ahead of former F-5. Glue the 1/4" x 1/2" strip parts on the front of F-4 and complete the noseblock by glueing F-3 in place. Figure 6 shows these details. The radiator grille is made from the mouldings supplied. Join two grille pieces and trim to 4-3/4" long. Glue 4-3/4" long pieces of 1/16" x 3/16" on each side to complete the "box." Make sure that all of the cross-bars are glued to these sides; and that the sides are level with the front (open) side of the moulding. Later, when the glue dries, the web holding all the cross-bars at the rear is sanded off, making an open grille very easily and accurately. See Figure 6A. Repeat the whole process for the other grille and cement the finished grilles over the large rectangular holes in F-3. Glue F-3B in place. (Discard second F-3B in other Sheet 2).

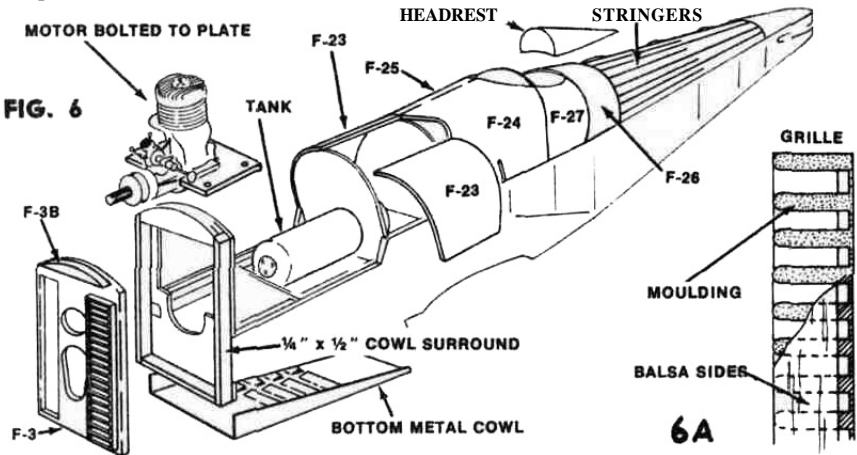

FIG. 6

13. Cut proper size hole in 1/4" phenolic engine plate for the engine you are going to use. Drill holes to suit and mount the engine. Fit the plate up to the fuselage (remove the needle valve temporarily if necessary) and when you have it fitting snugly down on the mounts, drill through plate and mounts simultaneously to insure accuracy for the mounting screws. Screw plate in place using the 3/4" woodscrews provided. Slide fuel tank in position and connect to engine with fuel tubing.

14. It is a good plan at this time to install the R/C equipment and the pushrod to the throttle. Due to the enormous variations in available equipment it is not possible to give precise diagrams for every R/C equipment installation: however, the motor-control servo should be fitted between **F-8** and **F-II**. In the original prototype models, a Kraft proportional KP-4B outfit was used, and it was found very convenient to mount the three KPS-10 servos for engine, elevator and rudder side-by-side on two 1/8" x 3/8" basswood cross-spacers, so that all 3 servos were between **F-8** and **F-II**. In this case the radio receiver was glued to the rear face of **F-11A** via a small foam rubber pad.

The battery will fit in the space between **F-5** and **F-8**. While it is true than an installation where the servos are ahead of the receiver is uncommon, this was one of the cases where it was warranted. So plan your own equipment installation at this stage. If you are a beginner at this, get the help of an experienced R/C builder! We cannot put too much emphasis on this point. It is probably true to say that a very high percentage of equipment malfunctions can be directly attributed to sloppy or defective installation. Remember a long life for your model (and the safety of spectators) depends vitally on good equipment installation.

15. After connecting the throttle to the motor-control servo, check for easy frictionless movement over the whole range of throttle travel. When satisfied, remove the engine, tank and servos before continuing with building, so as not to get any balsa dust, etc. in delicate equipment.

16. READ THIS COMPLETE INSTALLATION BEFORE STARTING.

The sheet panels **F-23**, 24, 25, 26 and 27 can now be glued in place. This may appear at first to be a very difficult job to do without breaking the pieces. In truth, it is very easy as long as the correct method is followed closely. We will explain using one example piece, and the rest of the panels all follow the same general idea. This is how to proceed:—

Take one **F-23** piece and glue the lower edge to the right fuselage side (use regular balsa cement). Let this joint dry thoroughly! If you try to continue too soon, the joint will come apart and you'll be back at the start, and have to re-glue and wait again. When dry, thoroughly dampen the **outside** of **F-23**, being careful not to wet the glue joint just made. You can wet the wood with a cloth and water. After a few moments, try pulling the sheet around the formers that it will be glued to. You will find that it will bend to the required curve very easily. Spread glue (this time use Titebond or white glue—not balsa cement) on the edges of **F-8** and **F-II**, and pin the wrapped sheet firmly to the formers to set. Masking tape also can be used to get firm contact.

The other panels are done in the same way. Glue **F-26** in place before **F-27**. Wet and attach one panel at a time. Start at the front again on the left-hand side. Notice the panels are of slightly over-width as cut—this is to allow final trimming of the left-hand pieces to exactly fit the right-hand ones already in position.

About the only panel that may give a little trouble is **F-24** on the left side. (This is why we had you do the right panels first—to get experience!) This is because of the tight radius at the front over **F-11A**; so do not be concerned if a small split develops here. After the panel has dried you can run some glue in the split or fill with vinyl-spackle (purchase this at a hardware store). Notice also, that a small clearance-cutaway must be made in **F-25** and **F-24** for the rear-strut wire. Any oversize of these holes can be filled later with vinyl-spackle.

17. From the 3/16" sq. supplied, cut seven pieces about 11-1/2" long and eight pieces about 6" long. These will be the rear stringers. Trim one of the long pieces to exactly fit from **F-14A** to the tail block and glue it into the notches in the center

of formers **F-14A • F-17**. All stringers are to be glued in "diamond-fashion" This was done to get sharp impressions on the covering, like the real S. E 5A had, and yet have stringers big enough not to warp after covering Glue in the rest of the stringers, observing that they are alternately long and short (see Figure 6). When dry, cut back short stringers level with rear of F-16 Carve and sand tail block to conform to fuselage shape

Shape the headrest block provided to section, and tack-glue in position so it won't get lost.

18. **Glue R-1 and R.2** together, also **R-4 and R-5**. Glue **F-10** (ply) on front of **F-8**, screw nylon brackets for upper cowl fastening onto **F-10** and **F-4**: see fuselage side view for positions

19. Screw upper and lower metal cowls onto fuselage Shape and sand nose block to correct contours and add dummy radiator-cap (made from scrap) Drill upper cowl for needle valve in required position by temporarily installing engine. While upper cowl is removed from fuselage, shape cylinder fairings from blocks provided, screw to upper cowl and finish making exhaust pipes from hardwood dowels provided Figure 7 shows final appearance

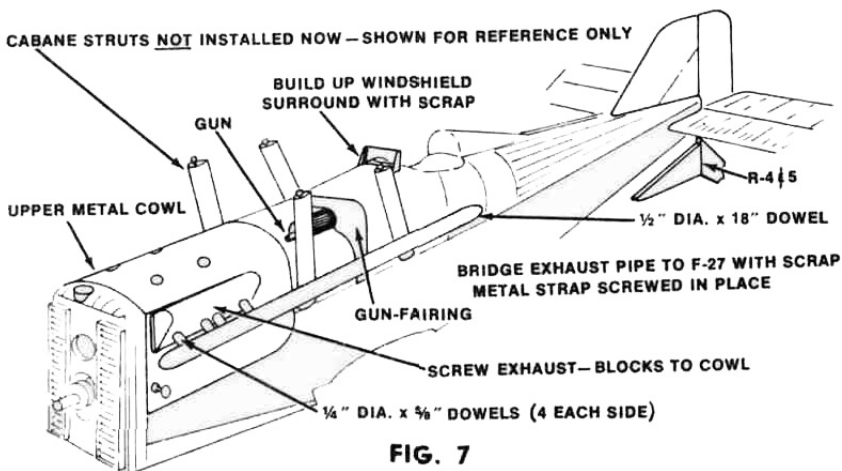

FIG. 7

20. Cut a suitable hole in upper fuselage decking and tack-glue Vickers gun in position, then cut out stiff card gun-fairing to template on plan and glue in position Build up windscreen, lightly tack-glue on fuselage Sand fin and rudder parts. Hinge together with material provided.

21. The whole stabilizer assembly, and the underfin (**R-4 and R-5**) may now be glued permanently to the fuselage Take care while installing these parts to get them properly aligned Lightly tack-glue the fin in position on the fuselage. Glue rudder horn to rudder

22. Screw rudder and elevator servos in place Make pushrods to rudder and elevator and check radio for smooth and free action of control surfaces. Bear in mind here, that the type of pushrods required will depend upon how much interior cockpit detail you intend to incorporate If you want, as we did, a completely furnished cockpit with instrument board, pilot, seat and all the rest of the details, it obviously will not do to have two big pushrods running through the center of the cockpit In the prototype models we used short lengths of nylon tubing with metal wire cable inside, from the servo back as far as F-14. From here back the pushrods became 3/8 sq in the normal way The nylon tubing section was fastened to the cockpit sides where it is hardly noticeable If it is not intended to incorporate a full cockpit layout, normal 1/8 sq pushrods all the way from the servos to the tail end will be all that is needed.

Specific details cannot be given for these pushrods, because as with the radio and engine, etc., requirements and equipment will differ from one builder to another. Whichever layout is chosen it will be found that there is ample space inside the model to carry out any desired positioning. However, we repeat to newcomers that the advice of an experienced R/C modeler will be invaluable.

23. Break up and discard false former **F-12** from the fuselage. Smear a coat of glue over the planking joint so exposed. **Do not** attempt to install cabane struts at this time. For this job we will need the wings, so let's start those.

24. Refer to Figure 8 which shows the first section of the wing to be made—the lower right-hand panel. Take one of the prejoined $1/4" \times 1/4"$ basswood wing spars and trim to exact length over the plan. Note that this is the longer rear spar. Slide one **W-3**, one **W-4** and six **W-5** wing ribs in this order loosely onto the spar, pushing them toward the center of the spar temporarily. The dihedral brace on the spar faces forward. Cut two pieces $8-7/8"$ long from the $1/8" \times 1/4"$ balsa strip provided, and glue these on top and underneath this rear spar at its outer end.

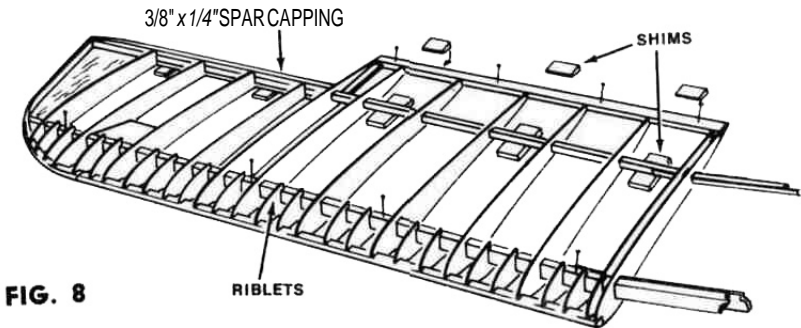

25. Take one of the pre-joined $3/8"$ deep basswood spars and cut to exact length over the plan. This is the shorter forward spar. Spread out the ribs on the rear spar and feed the forward spar through them from the root end, making sure dihedral brace faces rear. Slide three **W-6** and one **W-7** ribs onto the forward spar in correct order. Slide all ribs back and forth along both spars until they are all in **approximately** the correct positions.

26. Place scraps of $3/16"$ sheet or square balsa shims over the spar positions on the plan, except at the outer end of the rear spar, where the shims should only be $1/16"$ thick. Lay down the wing framework on the plan, with the spars held up by the shims. As it is not practical to pin through the hardwood spars, hold the assembly down with a few small weights, making sure it cannot move.

27. Shuffle ribs to exact position over the plan (tweezers are handy for this job) and lightly spot-glue each rib-to-spar joint. This will hold these joints while the structure is completed; later on all these joints should be carefully and completely glued when the wing is lifted off the plan and access is available all around each joint.

28. Cut a piece of pre-formed L.E. section to correct length and glue in place, shimming it up to the steps in the ribs with scrap $1/16"$ balsa. Pin and glue the pre-formed T.E. to the ribs, shimming up $1/16"$.

29. Glue two **W-11** pieces together for wing tip. While these dry, slip **W-8** riblets into place and glue. Trim front of outermost **W-6** and glue laminated tip **W-11** in place and complete the tip with short length of $1/4"$ sq. to rear spar. Glue in $1/16" \times 1/4"$ stiffener against outermost **W-5** rib, then riblets **W-9** and **W-10**. Glue **W-17** in place.

30. Glue in **W-12R** (ply) bellcrank bearer, noting that it lays at an angle. See full-size drawing of wing section at this point on the Plan Sheet.

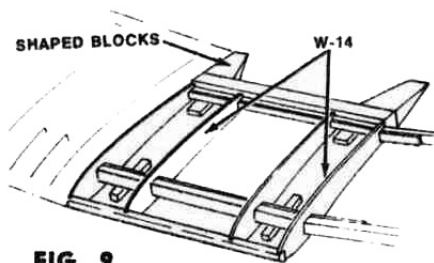

FIG. 9

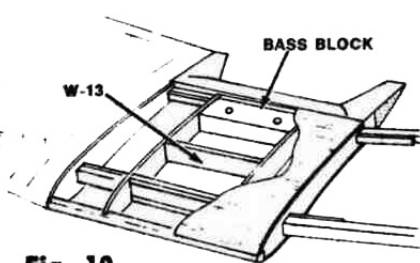

Fig. 10

31. Remove wing from plan. Slide four **W-14** ribs over projecting ends of wing, spars, getting them in approximately correct position in the wing center panel. As with the panel just made, weight down the spars with $3/16"$ shim under them. Slide ribs to exact position and glue. See **Figure 9 and 10**. Glue in **W-13** and $1/2" \times 3/4" \times 4"$ bass block. Glue on L. E., the balsa block. T. E. Pieces and cap spars with $1/16" \times 1/4"$ to support the center $1/16"$ sheeting, which is now glued in place. Don't forget to bevel one edge where the sheet sticks to the L. E.

32. Tilt the whole wing so the projecting spar-ends are now flat to the plan and construct the left hand panel in the same way as the right. Remember that ribs **W-3, 4 and 5** must be threaded onto the spars before the $1/8" \times 1/4"$ rear spar capping is glued on.

33. At this point turn the wing upside down and attach the formed rear landing gear wire strut onto the hardwood block in the center panel, using the metal clips provided. Make sure you stay clear of the hole positions in this lower block.

34. Again, cap the spars with $1/8" \times 1/4"$ and sheet the whole underside with $1/16"$ balsa.

35. Refer to Plan Sheet I and study the full-size view of the lower wing center section. Fasten formed front landing gear wire strut to **F-9** with metal clips. Glue **F-22's** onto wing. Glue two **F-9A's** together, and set aside to dry. Glue **F-9** to **F-22's**. Then sheet in lower edge with parts **F-19, F-20 and F-21**.

36. Bring up the lower wing to the fuselage. Trim or adjust parts if necessary. Aim for a perfect fit. When this is achieved, take off wing, check that the laminated **F-9A's** fit well into the hole in **F-8**. Sand if necessary. When satisfied, glue **F-9A** on the front of **F-9**, immediately putting lower wing in position on fuselage so that **F-9A** will be in exactly the right position. When glueing **F-9A** on, do not use too much glue, else some may ooze out of the side and glue up the whole assembly when the wing is positioned.

37. While these parts are drying, slip two solder-tabs on each front LG leg, then solder the landing gear plates to the legs. Use acid flux here, as a strong joint is essential!

38. After carefully marking the positions of the holes for the nylon wing mounting screws on the underside of the wing center panel, drill right through wing and the block in the fuselage at one time. Use a No 29 ($.136"$) drill. Remove the wing. Redrill the holes through the wing with a No 19 or No 18 ($.166" - .170"$) drill to clear nylon screw. Tap the No 29 holes in the fuselage block with a 8-32 tap. Trim away **F-19** to allow the heads of the nylon screws to seat right down against the wing block. When the model is finished, these recessed screw heads will be barely discernable, and will not spoil scale appearance. Try screwing the wing into place. See that all fits are perfect, trimming away or adding if necessary.

39. Slide the tabs on the front LG leg to the top of the leg, then glue all balsa pieces **LG-1** to **LG-6** to landing gear legs, clamp up securely and set aside to dry thoroughly. Give these parts at least two hours—overnight if possible, before sanding down.

When the legs are sanded down, bind them with the $1/2"$ tape supplied, wrapping the tape tightly in spiral formation. Rub glue into the tape. This tape will strengthen the landing gear and add to the scale effect.

40. All four ailerons are identical—except of course that two are left and two are right. Laminate each tip from two W-12 pieces. Construct flat on plan as in Figure 11. When dry, carve and sand L. E. and tips to correct section: see Figure 12.

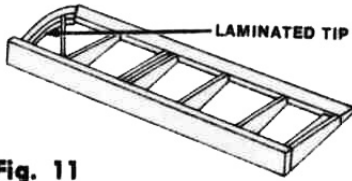

Fig. 11

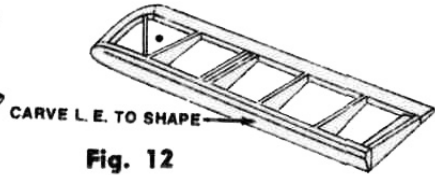

Fig. 12

41. Hinge ailerons to bottom wing—see diagram on Plan Sheet 1. The hinges should be held in place by toothpicks after drilling through wood and hinge material together. Cut down the nylon aileron horns supplied to correct size indicated on plan and glue between closely-spaced aileron ribs, using Titebond liberally to fill holes in horn. Clamp and let dry.

42. Install nylon aileron bellcranks on W-12 (ply) bellcrank bearers. Connect bellcranks and horns with supplied connecting links. Use small scrap of 1/16" sheet to support covering where link exits from wing under surface.

43. Mount aileron servo in lower wing center section. It will be necessary to make two right-angled brackets in most cases. For this purpose, two drilled metal strips are provided which can be bent and re-drilled to suit the application. Connect servo and bellcranks with 1/16" music wire pushrods, making the holes through the ribs in the positions required by the equipment involved. Try to keep the holes small—3/32" dia. is about right. Try out the ailerons using the radio, and do not be satisfied with less than perfectly free and smooth movement over the whole range of travel.

44. The top wing is made in three stages just as the lower wing, so detailed instructions are not necessary. The only points of difference are in the slightly altered rib-spacings, the lack of servo or bellcranks, and the center section which is rather simpler.

When making the center-section, note that the 1/16" sheet covering extends from the leading edge to the rear spar on the upper surface.

45. So far we have a complete fuselage and tail, with a lower wing which is mounted in position and an upper wing not yet attached. The next job is to bring these two items together to make a fairly complete S. E. 5A. This stage is a little tricky, so work slowly and carefully. Study the drawing of the strut attachment fittings on Plan Sheet 1. This nylon ball-and-socket joint is a new idea that we at Top Flite have worked out to greatly simplify the traditionally difficult job of rigging biplanes. This new system is far less demanding of super-accuracy than the usual wire-bending methods. Also, assembly and dis-assembly is easier and quicker and appearance much neater. (These fittings, incidentally, are available separately packaged, and biplane builders will find them very useful—they will take up any angle of strut attachment . . . sideways, backwards, forwards or combinations of these. Ask your hobby dealer for Top Flite E-51 package).

46. From the 1/8" x 3/8" basswood strips supplied, cut 12 pieces 1-7/8" long. Drill a 3/16" dia. hole in 8 of these 11/16" from one end and centered in the 3/8" width. Glue these to the spars (on top of lower wing spars, and underneath upper wing spars) so the drilled hole lines up with the first W-6 rib. Trim away ribs and riblets slightly where required. Refer to full-size plans to check location.

The 4 undrilled pieces are glued to the forward spars in line with the drilled strips already attached. These 4 strips will provide a covering-support for your left palm when snapping the struts in place.

Next cut 4 pieces of 1/8" x 3/8" basswood 7/8" long, drill 3/16" in the center of each piece and glue to the bottom of the spars in the lower wing at the dihedral-break, again trim away ribs to suit.

The nylon plates (sockets) are intended to be permanently screwed in place after covering and clear doping and prior to coloring the model. However, screw them in place temporarily at this time to aid in the further construction of the model. They should be removed later (see covering instructions)

47. Take one of the shaped hardwood wing-struts (1/4 x 3/4 streamline section) and cut off a piece about 8" long. This will be one of the forward cabane struts (see Fuselage Side View Plan Sheet #2). Sand a slight angle at the top end of this strut—see **Figure 13**. Drill a 7/64 dia hole into the strut from the end (Figure 14). The hole should be about 1" deep and 1/4" from the L E of the strut. Fill the hole with Titebond or epoxy glue and push in the threaded shaft of the nylon ball strut fitting (**Figure 15**).

This joint must be allowed to completely dry before anything more can be done with the strut.

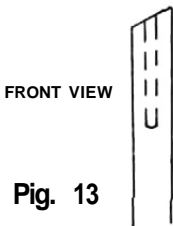

Fig. 13



Fig. 14

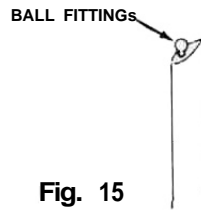

Fig. 15

48. Meanwhile, cut the other cabane struts and also the interplane struts from the formings. Always leave 1/4" or so of extra length, to allow for final tailoring at the assembly stage. One end of each strut can be angled and drilled, however, and the ball sections glued in. Note that the cabane struts are rectangular in side view (as the struts are supplied) while the interplane struts have a curved taper at each end. Carve this shape into the interplane struts and sand rectangular edges back to airfoil section.

49. When the first strut (front LH cabane) is set, snap the nylon ball into its mating socket, which is the nylon plate screwed under the forward spar of the top left-hand wing at the dihedral joint.

The diameter of the hole in the flat nylon piece has been designed to resist the ball-end on the strut to a fair degree. Therefore a firm push will be required. Once snapped in, however, the joint should be quite free to assume correct angle.

50. With both left and right forward cabane struts snapped into place on the top wing, cut out a hole in the fuselage sides immediately behind F-8; see Figure 16. Enlarge until the bottom ends of both cabane struts can be fed into the slots. Cut two pieces of scrapwood, one 2-1/2" long, the other 3-3/8" long. Pin these to the T. E. and L. E. respectively for use as incidence and height gauges. See Figure 17. When the whole assembly is fitting well, check that the wing is properly squared-up to the fuselage in plan view and front view (Sight by eye using the attached bottom wing

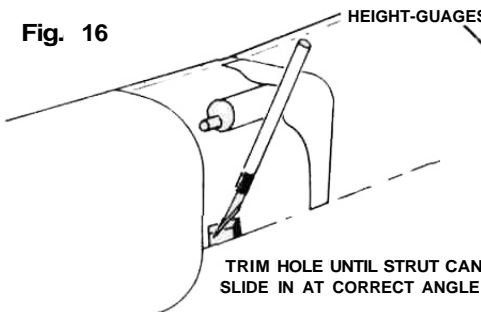

HEIGHT-GUAGES - LONGEST AT L. E.

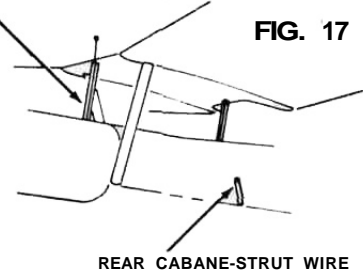

as a reference) When satisfied, run some Titebond into the holes at the strut-fuselage joint When this glue has dried and the top wing will not move out of alignment remove the bottom wing so that access can be had to the inside of the fuselage and liberally glue the struts to F-8.

51. At this point in the construction, all the most difficult work is done; now we re coming down the home stretch'

Snap the rear cabane struts into the top wing fittings Mark length and angle down to the stub wire projecting from the fuselage Disengage strut A good way to unsnap the ball is to insert the blade of a wide screwdriver in the gap between the wing and the end of the hardwood strut Twist the screwdriver and the fittings will disengage Cut and drill lower end to take wire Replace and remove struts, trimming as necessary until the fit is right Finally, with strut off the fuselage, fill holes in struts with glue and slip into place on the wire snapping top fittings together to hold alignment perfect while glue sets When dry, remove balsa height gauges

52. Fit the four interplane struts First cut the struts to exact length to fit between the nylon plates Then cut off 3/16" of length drill struts and glue ball fittings in place Constantly check that wings are parallel and at same incidence (L E top wing to L E bottom wing distance should be same as T E top to T E bottom)

53. Install all solder-tabs in position to be used later for wire rigging attachment

54. Solder the axle into the landing-gear plates. Trim the shaped hardwood axle fairing to proper length and angle, and glue to the legs with the axle running in the groove visible from the top

A completely rigid landing gear is, in our experience, by far the best for this type of model The small amount of springing incorporated into the axles of the full-size aircraft of the period, has proven of no value in cushioning landing shocks on models, and in fact, causes ground looping problems on take-off

55. The scale propeller is supplied as a shaped blank ready to be carved to section Carving propellers is an acquired art If you doubt your ability to make a good Job have an experienced modelling friend do it for you The many exterior details may now be built and installed temporarily, such as gun rail and gun, cockpit detail and so on

Smooth off rib edges, etc., and remove any bumps of glue that would spoil the covering Job

COVERING

Disassemble interplane struts and wings from model and remove nylon fittings from wing panels Remove from the model **all** tack glued items such as fin and rudder, guns, cowls, headrest, windscreen, etc. Remove engine, R/C equipment and also the pushrods if possible

Completely disassemble the whole model as far as possible into its separate elements After again making sure that all structure is smooth, we are ready to cover the model

WARNING: Some of the heavier fabric covering materials, such as nylon, heavy silks and blends of silk and nylon, are not suitable for models of this type They have too much shrinking power and will warp the structure Use only regular lightweight or Japanese silk to cover this model!

Start by giving all wood which will come into **contact with the silk two coats** of clear dope Use dope liberally, allowing each coat to dry

Sand doped areas **lightly** to remove the fuzz raised by the dope

Cut panels of silk to oversize and lay on model Paint around outlines with clear dope The dope will penetrate the silk and form a bond with the dope previously applied Stretch out all wrinkles as you go

Do not be concerned if the covering is a little loose. It does not have to be drumtight at this time—the important thing is that there should be no wrinkles or folds

When the dope has dried, lightly spray the silk with water An airbrush or perfume spray will be ideal When the silk dries it should have shrunk quite tight

If there are places where it has not tightened properly or there are wrinkles or folds remove that panel of silk and do it over. Never expect the shrinking action of the clear dope that is applied next to pull out a bad covering job. It never does — dope will not shrink out wrinkles that water cannot remove. Clear shrinking dope can only make an excellent job of an already good one.

When you have a good covering job, give the model 3 or 4 coats of clear dope. Thin the dope out. Two thin coats are better than one thick syrupy one. If you have a spray you will get a better job.

One piece of advice regarding clear-doping is worth passing on: When doping the wings, give a coat to the top of one panel and immediately coat the bottom of that panel. In this way the wing will be subjected to even stresses all around and warping will be minimized. Do one panel at a time. The same goes for the stabilizer, elevators and ailerons.

Inspect the wings, ailerons, and stabilizer for warps. Remove any that are present by holding near (not too near!) heat and twisting gently in the opposite direction. Take care here, as warps will have a very bad influence on the flying characteristics.

When the clear doping is completed, proceed to the color. Color dope should be sprayed if at all possible. The nylon strut fittings can be replaced prior to color doping. Give at least 3 coats of all colors.

Since most, if not all, S. E. 5A's were doped with matte camouflage dopes, we now have to kill the unwanted high gloss that our regular model dopes give. The best way to do this is to spray a coat of clear eggshell lacquer over the colors. Be sure that the lacquer you use is fuelproof—polyurethane varnish is very suitable and can be obtained from hardware stores or paint stores. Normally such varnishes will **not** be found in model shops.

Finally, add the decals in positions indicated on the plan. Many S. E. 5A's had the words "LIFT HERE" along the bottom longeron together with a small white arrow. The particular S. E. 5A we chose, Mike Mannock's D'278 did not have these markings, but if you choose to paint your model with a different serial, you can use the words LIFT HERE and the small arrows which are provided on the decal sheet.

FINAL DETAILS

Like all full-size aircraft, the S. E. 5A was loaded with small details, such as radiator cap, pilot tube, sumps, and dozens more. Probably, most "Sunday Fliers" will not want to incorporate these. But for the contest flier, or modeler who is making this model for static display purposes, and wants to incorporate these details, cockpit furnishings, etc., we have given drawings on the plan to enable these details to be made.

If you intend to go this route, we recommend the book, "S. E. 5A" by Charles L. Bourget available from World War I Aero Publishers, Box 142, West Roxbury, Massachusetts 02132, at \$1.95. The drawings in this book are the ones we used in scaling the model, because we considered them the most accurate obtainable for this aircraft. We have reproduced these drawings on our plan, enlarged to $1/2" = 1'$ scale as an aid to contest fliers in preparing their "Proof of Scale" documents.

The "Profile" Publication of the S. E. 5A is also recommended, and will be especially useful, along with our box label, in giving guidance to correct coloring of the model. The "Profile" (No. #1) is obtainable at most hobby shops and costs 50c.

RIGGING

Due to the scale wing section being so thin, the wings are very flexible. In our considered opinion the wings would not be strong enough for flying if left unbraced. When correctly rigged, however, the strength of the "box-kite" wing configuration is enormous, and will withstand any amount of severe maneuvering in flight with strength to spare. To have made the wings sufficiently strong as cantilever structures in the design stage would have been possible, but at the expense of considerable damage to scale effect, by way of a wing section of twice scale thickness and areas of sheeting. We chose to make the model true scale and

make the rigging wires, which **have to be added in any event, perform a real and important function.**

After all the dope on the model is completely dry, screw the lower wing in place on the fuselage. Snap the upper wing onto the cabane struts. Snap the four interplane struts into the wings. The rigging wires are made from the 020" piano wire supplied, and are called "flying" and "landing" wires—the "flying" wires are the ones tensioned in flight, that is, the ones running from the fuselage up to the upper wing the "landing" wires are the ones tensioned in a landing, that is, the wires running from the top of the cabane struts down to the lower wing

As with the strut fastening method, we have given a good deal of attention to figuring a simple and fast way to install the rigging wires. We did not want to use turnbuckles. (the traditional method of getting the correct wire length) because they are tiresome and must be reset every time the model is disassembled for transportation

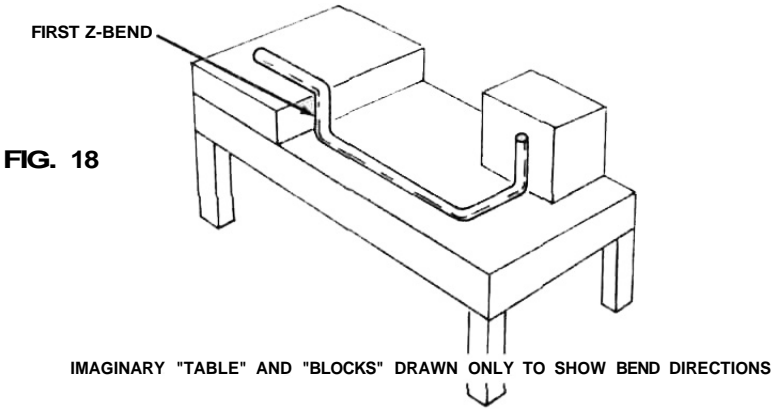

The method we have devised will take a little patience to bend the wires, but once done, the wire length is set permanently, and the wires can **all** be removed and replaced in seconds. Follow this method:

- Start by making the **longest** wires first. This way, if you accidentally bend one too short the same piece can be used for a shorter wire later on, saving waste. Work through to the shortest wires, doing these last.
- Leaving the wire the full 30" length, make a small normal Z-bend at one end. See Figure 18.
- Hook this Z-bend into the solder tab at the top of the front interplane strut on the left side
- Holding the wire in slight tension, make a mark on the wire (use a felt-tip pen) where the wire passes the solder-tab at the top of the front L. G. leg.
- Unhook the Z-bend. Bend the wire at the pen mark 90°. Now make another 90° bend about 1/8" further along **perpendicular to the long straight section**. Again, see **Figure 18**.
- Cut off the wire about 1/8" along the new direction. The wire is now made. Let's see if it fits o.k.
- See **Figure 19**. Hook the original Z-bend back into the tab it came from. Now, by grasping the wire at the lower end with pliers and **twisting** it, hook the other end into the second solder-tab. We are using the **torque** in the wire to keep the bottom bend in the tab, and unless the rigging wire is **twisted** the bottom bend cannot disengage. This cannot happen in flight: however, removal is simply performed by grasping the wire near the bottom with pliers and twisting until the wire disengages.

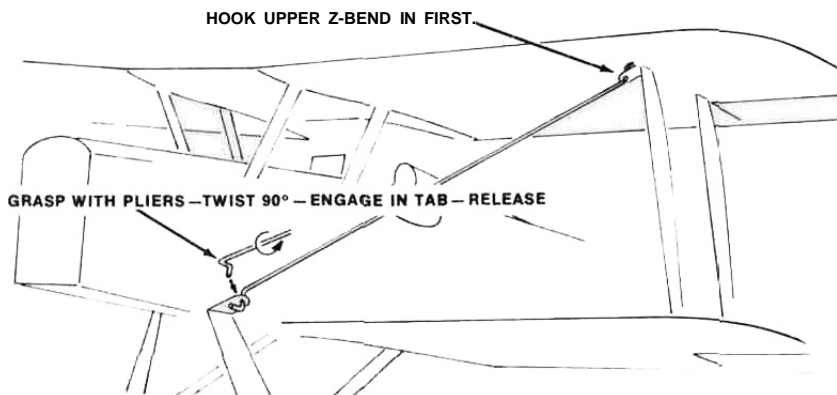

TO DISASSEMBLE REVERSE INSTRUCTIONS

FIG. 19

- h Test the wire for tension When plucked the wire should feel taut If the wire is slack this is no good and a new wire must be made—note how much shorter it has to be If, on the other hand, the wire is bent too short it cannot be engaged at all since it will not reach the second solder tab
- i All of this might seem terribly difficult to get "just right" but we can assure you that after making one or two mistakes, you will be making almost all of the rest of the rigging wires "dead on" first time! Your judgment quickly attunes to the requirements of the wire

With all the rigging wires in place on the model, a method of identifying each wire must be seen to A good way is to color code each wire with a small Jab of dope at one end Keep a list of the wires and the color-coding in your flying field kit

AILERON CONNECTORS

These units are very simple Cut the tiny horns out of scrap 1/16" ply **after** drilling the 1/16" dia hole Make a small slit in the covering and glue the horns in position—top of lower ailerons and bottom of upper ailerons

With the wings completely wire rigged, set the lower ailerons dead neutral, using the links to adjust as necessary

Bend one end of the 9" long 1/16 wire supplied 1/4" from the end and at a 90° angle Fasten this end to the lower aileron using a nylon button retainer to keep it in place Hang a connecting link in the upper horn, cut the wires level with each other and join with a short tube soldered in place See **Figure 20**.

Adjust the connecting link so the upper aileron is also at dead neutral

later, when trimming out the model in flight, each aileron can thus be adjusted individually for the best result

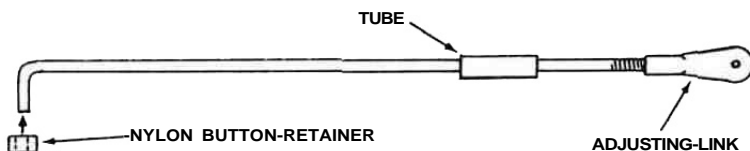

FIG. 20

PRE-FLIGHT CHECK

This is probably the most important Job to do on any model Right here is where the complete success of the maiden flight is organized A somewhat tire-some task to do properly, but hurry here can lead to an expensive crash Let's break down the pre-flight check into three units.

1. Balance
2. Alignment
3. Equipment

First, **balance**. The model should balance level to the ground or slightly NOSE DOWN when supported by its wingtips on the fingers or some blocks at the point marked CG on the plan (sheet 2) This is exactly half-way between the leading and trailing edge of the upper wing

Due to the naturally good layout of the S E 5A for modeling, it will almost always balance properly However, if it becomes necessary to alter the balance point, try to do so first by moving some fairly heavy item of equipment (such as the battery) to a new location If this is not possible, weight must be added to nose or tail

However, much is needed this must be put in the model While it is admittedly a shame to add, say, half a pound of dead weight, it is the only answer Never be trapped into thinking that the extra weight will do more harm than incorrect CG location'

If your model is nose heavy (CG too far forward) the worst that can happen is a slight sluggishness in control response This presents no problem and can be rectified before the second flight. With tail-heaviness, however, there is frequently NO second flight'

Second, **alignment**. This check consists of finding out if the incidences of the wings and stab are correct Proceed as follows Stand the model on its wheels on a level surface—a dining room table will do fine Now block under the tailskid with books, etc until the measurement from the table up to the L E of the stab is the same as up to the T E of the stab It is important, of course, to have previously set the elevator at dead neutral Having got the stab accurately parallel to the table, measure the incidence of the lower wing

To do this, measure up from the table to the middle of the L. E at the dihedral break Make a note of the figure Now measure from the table to the T E point, at the same dihedral break This second figure must be somewhere in the range of The same as the first figure to 3/16" less than that figure. (That is, between 0° and +1° incidence)

Finally, check the upper wing incidence This is very simple At the same dihedral break as used before, measure the L E bottom to-L E top wing then the T E bottom to T E top wing The figures should be the same It is allowable to have slight positive incidence on the upper wing relative to the bottom one That is, if the T E -to T E measures 1/8" or so less than the L. E.-to-L. E. figure, do not be concerned

As long as care was taken during the construction it is doubtful that the alignment will prove to be wrong beyond the tolerances allowed If, however, such is the case, make the necessary alterations by regarding the lower wing as correct and aligning the upper wing and the stabilizer to this Trimming the length of the two forward or the two rearward cabane struts will decrease or increase the incidence of the upper wing respectively (also trim the interplane struts to match), the stabilizer can be brought into alignment with the lower wing by cutting it free from the fuselage and re glueing it back after trimming-out the rear fuselage sides to change the angle as required

Lastly, **equipment**. Switch on the radio and check carefully all control surfaces for free movement Eliminate any overfreeness that could cause rattles Check motor control Do not be satisfied with less than full 100% perfection in this area' To lose a good model from **accidental** causes is bad, to lose one because of hurried checking of RC equipment is unexcusable because **it could have been avoided**.

PRE-FLIGHT RUN-UP

Before actually committing the model to the air, it is a very wise precaution to perform a simple "flight-conditions" check by running-up the engine and checking the radio on the ground. On arrival at the field, proceed as follows:

- a. CHECK OPERATING FREQUENCIES OF OTHER MODELERS PRESENT!
- b. Remove upper cowl. Fill fuel tank and start engine. Adjust to correct high—RPM.
- c. Set engine for idling—RPM. Stop engine. Re-start and stop several times to be sure you can start the engine easily and quickly when it is at **idling—RPM setting**
(This latter point is very important! While starting, under some circumstances, flooding for instance, an engine will occasionally spit burning fuel onto the model and begin to set it afire. This is no problem when the engine is uncowed because it is easy to just blow the fire out: however, you cannot do this after the cowl is screwed on. When the engine is started at **idle** setting this occurrence is prevented by the exhaust-baffle blocking the exhaust port. We draw this matter to your attention because "forwarned is forearmed").
- d. With engine running, switch on radio and hold model up by its upper-wing center-section. Check all controls, including motor RPM.
When satisfied with results of the run-up test, we are ready for the all-important moment!

FLYING THE S. E. 5A

For the expert at flying radio-controlled models the S. E. 5A will present few problems. About the only area in which care will be needed is in the take-off run, where there sometimes is a tendency to ground-loop. We have discovered that this happens mostly when a take-off is attempted with gradually increasing power. The answer is to snap the throttle open from idle quite sharply, the resultant sudden power burst will allow the model to take off straight and well. If possible, avoid rudder corrections during the take-off run as the model is abnormally sensitive to rudder and it is easy to apply too much correction.

Ground-handling characteristics on slow engine speed, however, are very good. "Slipping" the throttle for ground steering looks and sounds good on a model of this type.

In common with other biplanes, with their high drag of struts, wires, etc., the glide of the S. E. 5A is flat but fairly steep. The airplane does not have the aerodynamic "cleanness" to make long low approaches with a dead engine. Therefore always try to land before the fuel is all used, so that the engine can be used for making a good approach-path.

To the newcomer, or modelers of little flying experience, who need **to know** the best method of handling the first flight of the model, our advice has to be "Don't!" Give the model to an experienced clubmate or friend to make that all-important first trimming-flight. Once trimmed, the model will be no more difficult to fly than a regular Taurus-type model. Neither is it any easier. Flying experience cannot be taught in written instructions such as these—it must be acquired over a period of time. So proceed with caution—and get all the help you can during the early stages of learning to fly.

In addition to the actual construction sequence of this model, we hope that we have passed on to you some helpful ideas gathered from our own experience. If you follow along these lines we know that building and flying your S. E. 5A will be a rewarding experience.

Best of Luck!

Designer
TOP FLITE MODELS

R/C MODELS

FOR MODELERS WHO INSIST ON THE VERY BEST!

KWIK-FLI III

MULTI R/C WORLD
& NATIONALS
CHAMPION

Wingspan: 60"
Length: 53"
Wing Area: 660 sq. in.
Engines: .45—.61 **39.95**



WINNER OF THE
1962 NATIONALS

TAURUS

Most precise and complete R/C kit ever produced.
Span-70" Eng-.45 Kit RC-7
TAURUS WING KIT-RC 7-W 13.95 **34.50**



HEADMASTER

Wingspan: 49" Engine: .09-.35 T.A.C. construction
Kit RC-11 **14.95**



WOOD



NYLON

THE PROPS OF CHAMPS. A size for every flying requirement. TOP FLITES and POWER PROPS have been used by more NATIONALS and WORLD CHAMPIONS than any other brand. Each prop is perfectly balanced and aerodynamically designed for maximum thrust.



TAURI

NOW includes ailerons & fittings. Multi channel trainer. Span-57" Eng.-.15-.45 Kit RC-4 **23.95**



TOP DAWG

Suitable for escapement, servos, galloping ghost, reeds or even proportional gear. T.A.C. construction. Wingspan: 39.5"—Length: 32" Engines: .049-.15 Kit No. RC-10 **12.95**



SCHOOLGIRL

One wing or two. Span: 32" Engines: .020-.049
Kit RC-9 **6.95**

SCHOOLMASTER

Single or multi channel with rudder, elevator and engine control. Span-39" Eng.-.049-.090
Kit RC-8 **7.95**

PRICES SUBJECT TO CHANGE WITHOUT NOTICE

Top Flite model airplanes must meet the most rigid standards before they are made available to the public. Every Top Flite model goes through a series of experimental design and performance tests. Production line models are constantly tested both in the engineering department and in the field for quality of materials, workmanship and manufacture, precision engineering and "fly-a-bility." It is, therefore, no accident that more Top Flite Models have won more Nationals and World Championships than any other models.