

# A FLYING SCALE MODEL OF

## THE S. E. 5.

### A One Ounce Model with Remarkable Flight Characteristics

By HOWARD McENTEE

#### Fuselage

Secure a flat board and lay out on it the top and bottom longerons from the side view, Figure I, with all connecting uprights and diagonals. Put the 1/16 inch square longerons in place, holding them with pins, and then cut the uprights and glue them in as you go along. Use pins plentifully, but do not put them through any of the wood—only along the sides. Put the three diagonals in last. Make two of these sides exactly the same. Allow three quarters of an hour for the glue to dry, as the sides will spring out of shape if not absolutely dry. This work may be done directly on the board; a razor blade will easily loosen it.

The sides are then set upright and formers 1, 2, 3, and 4 glued in place, together with the corresponding lower cross pieces, making sure the sides are at right angles. The extra lower cross pieces A and B shown on the top view, Figure III, must not be omitted as they take the strains when a lower wing strikes an object in flight.

After the glue has set, the rest of the formers are put in place, one at a time, starting with No. 5 and going back, each with its lower cross piece. All formers are 1/32 inch balsa.

The radiator can now be cut to size, and glued in place after the hole has been made. The cockpit is outlined with 1/16 inch reed. The stringers are made of 1/16 inch soft balsa and glued in. They are not all shown in the drawings as it would be confusing. Four are needed in front and three in the rear. The short ones from the radiator to No. 8 former should not be forgotten. Do not put in the rudder upright yet.

THE history of the S. E. 5 is fairly well known, but not as widely known as that of the famous SPAD and others. The reason probably is that it was a late development in the World War.

The letters "S. E. 5" mean Sopwith Experimental No. 5. The motor was an Hispano Suiza of 200 H. P. The top speed was over 120 M. P. H., and the climb was exceptional. It was one of the smallest ships used by the Allies, having a wing spread of only a little over 26 feet.

The machine was seldom camouflaged, usually being finished entirely in aluminum. Colored this way or left in white with the proper circles and stripes, it makes a beautiful model.

Incidentally, these fine ships have been used extensively in many parts of the world since the war as sky writers. This strenuous work was an easy matter for the agile S. E. 5.

The model to be described is an exact scale copy, no concessions whatsoever being made, except, of course, for a model size propeller. The S. E. 5 makes an excellent subject for model work due to the long tail, the dihedral, and the simple construction possible. It is also well balanced for flight.

Most of the balsa used is of the medium variety. Reed is used for tail surface because it permits easy adjustment of performance, and is, besides, very easy to form. The wings are adjustable by a method described in the construction section. This scheme of adjustment makes it easy to counteract propeller torque and control performance of the model.

Now let's begin construction.

NOTE: Construction Drawings are full scale

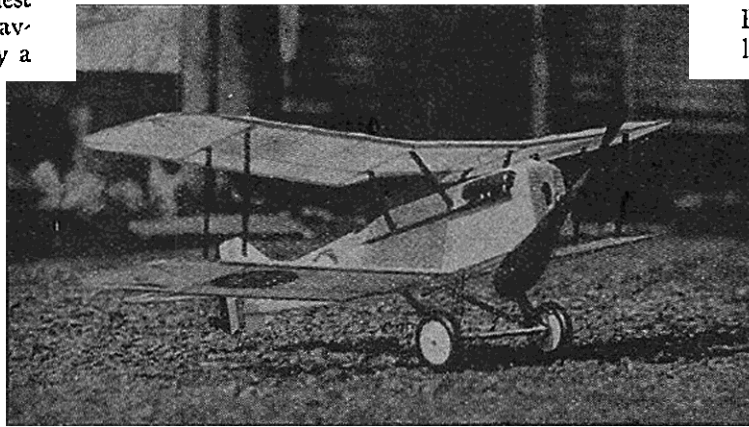

The Completed Model which is difficult to distinguish from a Real Ship.

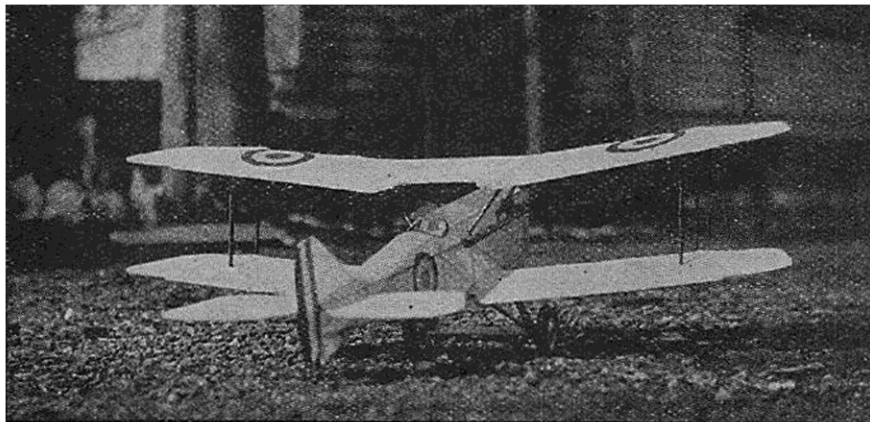

Good Looks? Yes, and better yet, Excellent Flights.

The front motor clip of .032 music wire is made as shown in full size sketch in Figure I, and glued on back of radiator.

### Landing Gear

**T**HE landing gear struts are all of 1/16 inch flat and fairly hard balsa. The edges should be nicely rounded off, but do not cut off too much or they will be weakened. The double front struts are made in one piece, 1½ inches long. They are glued to the bottom of the lower longerons, each being held with a single pin. When the glue is set, the rear struts are similarly put in place. The cross piece is sanded to a streamline or air-foil shape and glued to the bottom of the struts. If this work is done while the glue is set but still plastic, the landing gear may be trued up properly, then held with weights until it is fully dry.

The tailskid and rudder upright are made all in one piece from bamboo, but should be laid aside until the horizontal tail surfaces are in position. The axles are made from .032 music wire. The detail is shown in Figure IV. The single loop gives them more spring to help on bad landings. It is made by bending the wire once around a 1/8 inch nail, held in a vise. The axles are glued and bound to the bottom of the spreader. The wheels are 1¼ inch in diameter and may be of balsa or celluloid. They are held by bending the axle end back.

### Tail Surfaces

As stated in the introduction, these are made with a reed outline, which is bent as follows: place the magazine page on the flat board—it need not be detached. Lay a sheet of wax paper over it, then outline the inside of all curves with pins, spaced about 3/16 inch apart. None are needed on the straight parts. Soak the reed in hot water for about fifteen minutes, then remove and wipe off excess moisture. Start with one end near the rudder post or upright and run it around the outside of the pins until the other end is again at the rudder post. The reed will bulge out between curves, and more pins should be placed in these places to hold it in the proper shape. These must be put in as you progress around the outline; do not

wait until afterwards. If the reed tends to bend upward, two pins crossed over will cure the tendency. Follow this method in making the outline of the rudder.

When the horizontal tail reed is thoroughly dry, the inside bamboo cross pieces are put in, leaving the reed pinned just as it was. The long bamboo spar is 1/16" x 1/32". The ribs are 1/32" x 1/64" bamboo. The reed is cut half through in the center where it crosses the long bamboo spar, so that it will not be so far out of line. When dry, the pins are taken out and the horizontal tail is removed and glued to the underside of the top longerons, making sure it is trued up all ways. Small weights will hold it until the glue dries.

Now the combined rudder post and tailskid is glued in place and the rudder outline glued on. The lower fin outline piece of 1/32 inch square bamboo, and the long tailskid piece may be put in place now. Do not glue the latter at the lower end, only the upper. After the rudder outline has dried, the two ribs of bamboo, 1/32" square, are put in.

The .032 wire pin to hold the motor stick, shown in Figure I, is glued in place. A few turns of thread will hold it while the glue sets. This method of holding the stick is better than a clip, because it allows the rubber to twist the stick and no strain whatsoever is put on the body.

### Motor Stick

The motor stick is of medium balsa, 11" x 3/16" x 1/8". The rear hook is fastened by thread and glue to one end. The small pin hole is made in the rear of this same end. The propeller hanger is of 1/16" thick aluminum, 1/8" x 3/4" before bending. The hole is punched or drilled 1/8" from one end, and the piece is bent 5/16" from the same end. Any ready made hanger of similar dimension will be equally satisfactory. The hanger is bound and glued to the top of the motor stick. Be sure that the stick fits into the fuselage correctly before proceeding.

### Propeller

The propeller is made from a block 5½" x 1½" x 7/8". Before carving, it is cut to shape as shown on the figure. When the blades are cut, they

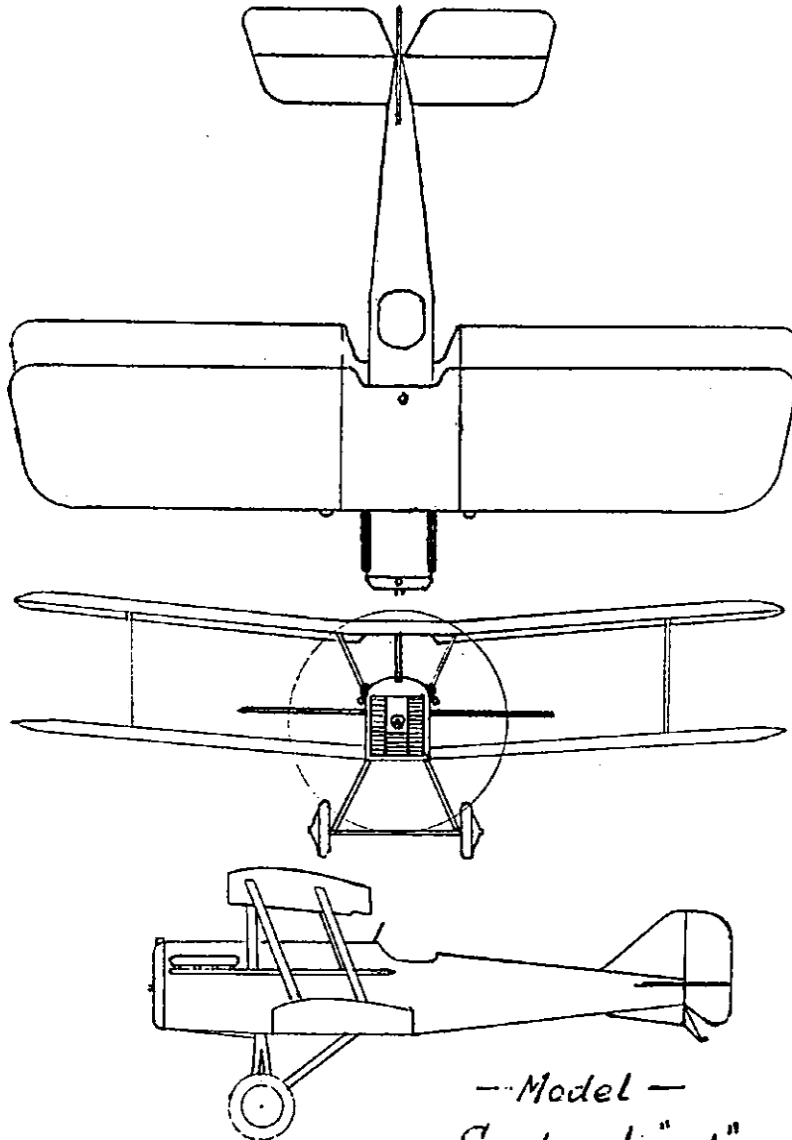

- Model -  
Scale = 1/4" = 1"

(Continued on page 42)

## Flying Scale Model of S. E. 5

(Continued from page 14)

may be tapered to a shape somewhat pointed at the tips. The propeller is finished with fine sandpaper and it must be carefully balanced. The shaft of .032 wire is glued in place and a small washer is glued to the rear of the propeller.

### Wings

The first step is to cut all ribs to correct size. There are 18 of them all told, of four types as follows: 8 of shape No. 1 and 1/32" thick, 6 of shape No. 1 and 1/16" thick, 2 of shape No. 2, 1/16" thick, and 2 of the same shape 1/32" thick. Be sure the ribs of one shape are all of the same curve by piling them up and sanding the whole pile together.

The leading and trailing edges are 1/16" x 3/16" balsa. The tips are of bamboo and are all from a single piece 5/16" x 1/16". After the proper bend is obtained, the piece is split into four parts and these are trimmed down to 1/16" wide and 1/32" thick. You will then have four tips just the same size.

THE wing outlines, with rib positions are laid out on a board and the wings built up. The No. 1 shape 1/16" ribs go where the struts end, and the 1/32" ones go in between where there is not so much strength needed. The No. 2 shape 1/16" ribs are at the inside ends of the bottom wings, while the 1/32" ones go in the center section.

The top wing is made flat on the board and all in one piece, but the top 1/16" square spar is left out. When the glue has dried on the ribs, the two edges and the rear spar are cut half through with a razor blade and the spars carefully cracked. Do not break them completely, just crack them sufficiently to enable the outer rib on each side to be raised 9/16", where it is held by blocks of wood, while glue applied to the cracked spars hardens. Then the top front spar is glued in. When absolutely dry, the edges of all the wings are rounded and smoothed with fine sandpaper.

As shown in the top view of the upper wing, small blocks of cork are glued on. The tops of the forward interplane struts have an ordinary pin glued on each. This pin, stuck in the cork, will hold very well, and the wings may be adjusted for propeller torque or change of performance.

The struts are all of 3/32" x 5/32" balsa with the edges nicely rounded off.

### Covering and Assembly

Before covering, the center section struts are fastened in place with glue, being held temporarily with pins. The angles and approximate length can be checked from the drawings.

The model is partly covered before assembling, as this makes both jobs quite a bit easier. The fuselage is covered first. No set rules can be given, but do not try to cover too much with one piece of paper, especially around the nose, where the many struts make the job a little difficult. Also, always run the grain of the paper lengthwise. This rule goes for the wings too. When the entire fuselage and tail surfaces have been covered, the wings are taken up. Cover the bottom of the top wing and the

top of the bottom wings only, at this time. Be sure to follow this direction.

Small holes for all strut ends are cut in the paper with a razor blade point. The top wing is glued on first. When it is fairly dry, the bottom wings and connecting struts are put in. Again no rules can be given except to go slowly and with care so the job will be trued up when finished, the much used pins being again employed.

When the assembly work is done satisfactorily, the remainder of the wing coverings may be put on. You will find you have saved yourself a lot of work by following the recommended covering procedure. When all covering is finished, the whole model is sprayed with water. This is done with an ordinary household atomizer. The paper is just lightly sprayed, not soaked, and if done this way, you will have a fine, tight job when it has dried. No dope of any kind is used.

The propeller is assembled on its stick with several flat washers between it and the hanger. Flat rubber, 1/8", is used, the best amount being determined by trial. Start with three strands. It might fly on less if built very light.

### Flying

WITH motor in place, it will probably be found that the model is tail heavy, and a small weight must be added to the nose. If the propeller was made of white pine, this would about make up the weight needed. If not, strip solder may be used, held on with a rubber band while testing. When the right weight is found, it may be glued inside on the radiator.

When the model glides steadily with no tendency to stall, the rubber may be wound, about 80 turns for a start. If the model persists in stalling, proceed as follows: remove the motor stick; from a strip of thin metal of any kind, cut a piece 1/8" x 1/2", and make a "V" notch in one end; then bend this piece and bind it on the motor stick, with the propeller shaft in the notch; adjust it so the shaft points slightly downward, the amount of tilt is correct when the model flies without stalling. See the detail in Figure VI to make this clear. This same arrangement can be used on almost any balky model to cure stalling.

### Decoration

The British circles are put on upper and lower wings, and stripes on the tail. All struts, landing gear, wheel tires and tail skid are painted black. If the dummy motor and exhaust pipes are put on as shown on the small assembly drawing, these are also painted black. The radiator, wheel centers and axle are white. The propeller may be silver. If the wooden parts are rubbed with ordinary white paste, and, when this is dry, coated with quick drying lacquer, a beautifully shiny job will result. A small celluloid rectangle 5/8" x 3/8" makes a good windshield. By studying any picture of an S.E.5, many details will be seen which will add to the value of the model.

In conclusion, remember this is a lightweight, though strong, model, and should not be flown in bad weather. The model as made by the author weighs a bit less than three-quarters of an ounce. Any weight up to one ounce or a little over is fairly good, for there is plenty of area to support it.