

DemonGti's ***Big Flat Ultimate***

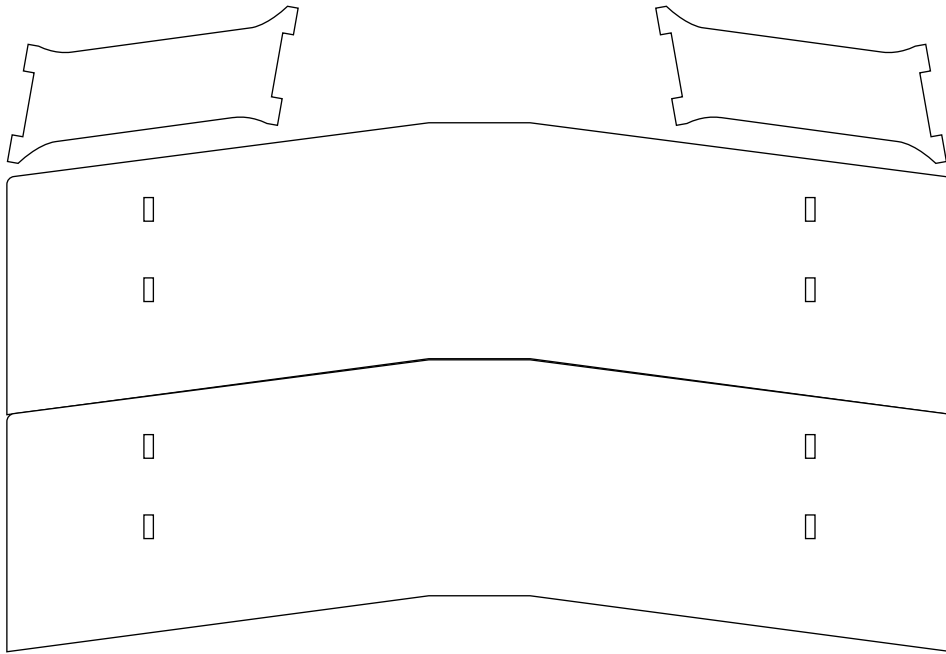

Firstly, thanks for building my BFU.
(This document is a guide only and is not to scale)

- 1 Cut out the two wings and the wing struts, butt the wings together (saves time and material)



- 2 Using fine sand paper and a sanding block, carefully round off the leading edges of both wings. Cover leading edges with 2inch clear tape.

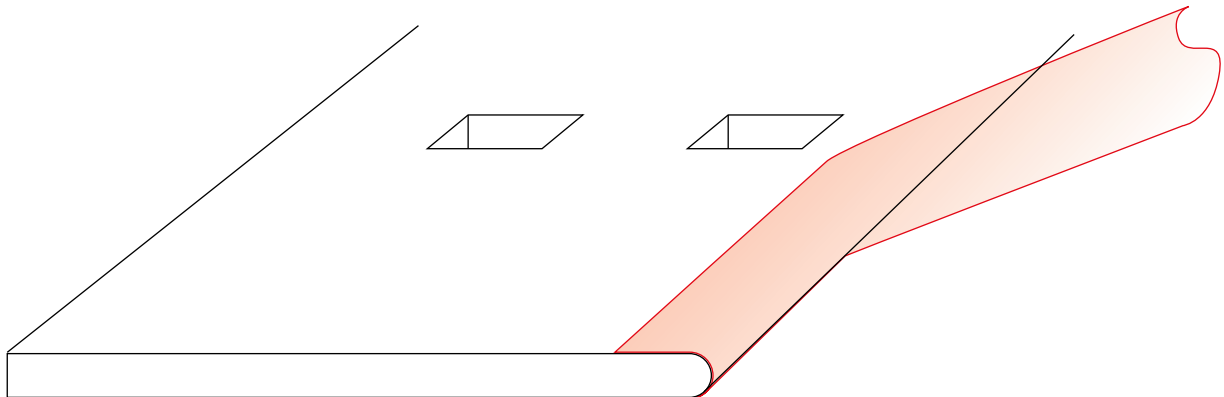

- 3** Cut out the aileron from both wings and trim off 2mm from the inside edge.

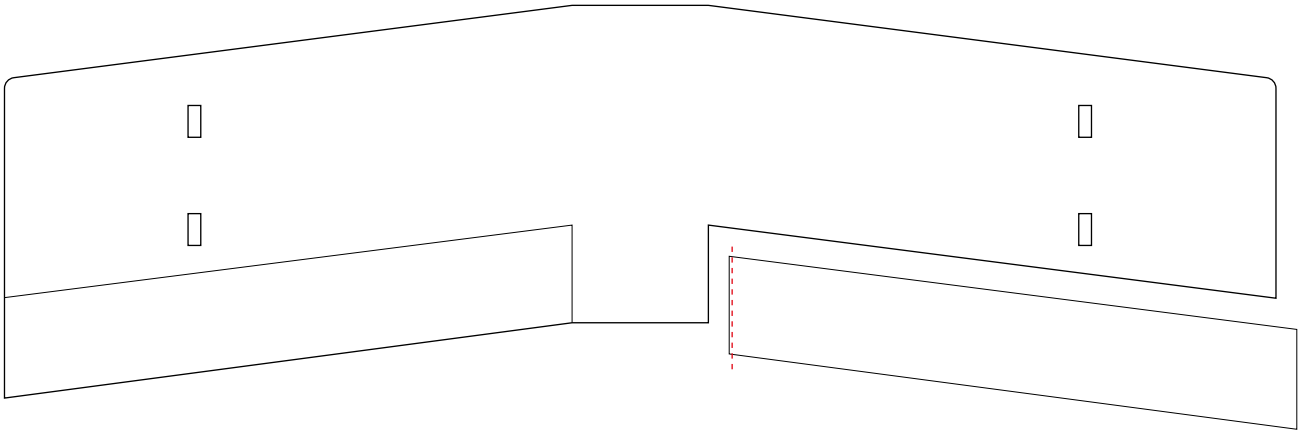

- 4** Trim off a 45° angle on the bottom side of the leading edge of all four ailerons using a sharp craft knife and a steel rule on the edge of a suitable table/work surface.

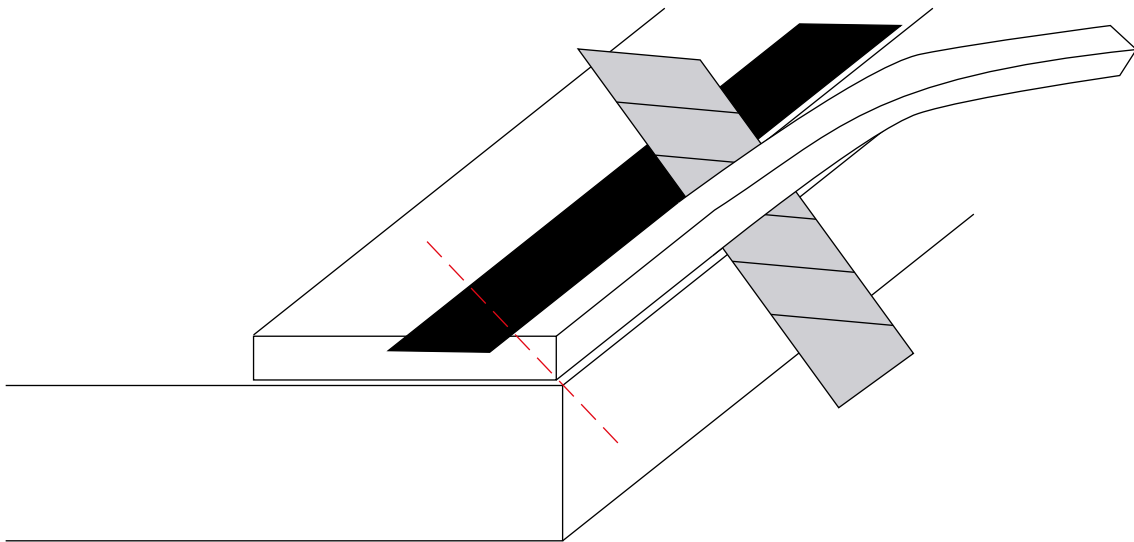

- 5** Lay wings face up on the edge of flat surface and place ailerons on top of wings and secure with 2inch clear tape.

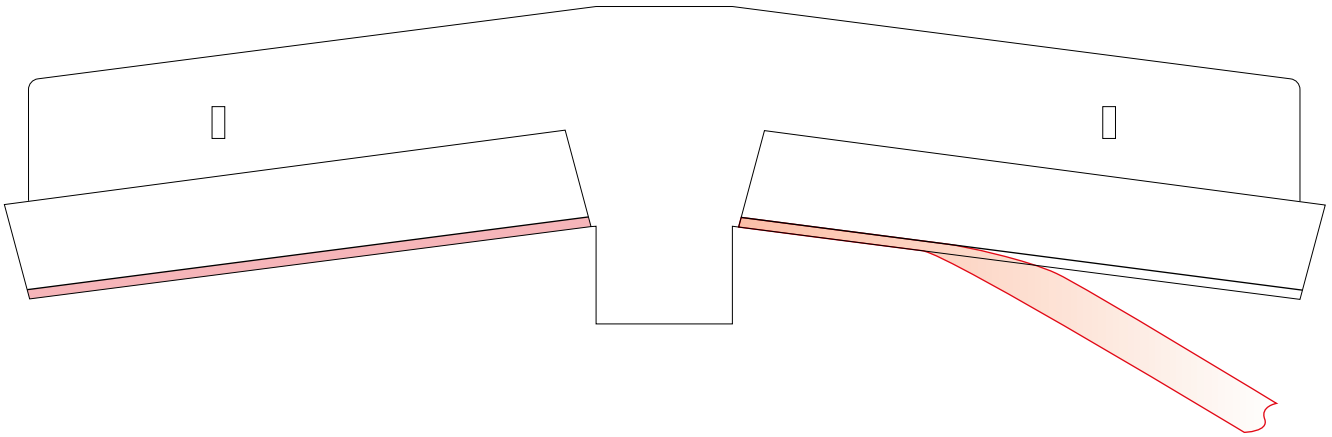

- 6** Apply tape to top side of ailerons

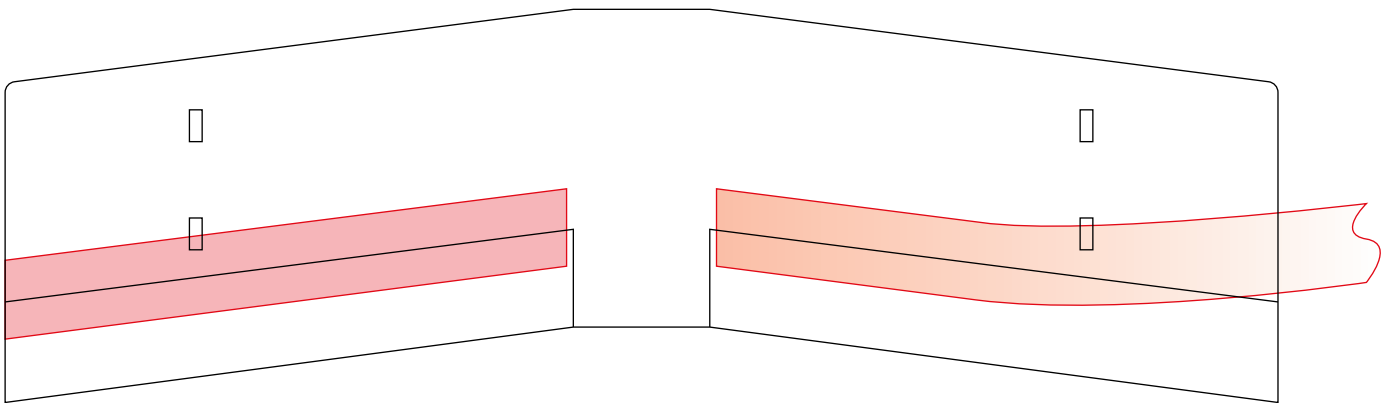

This is what the end result should look like

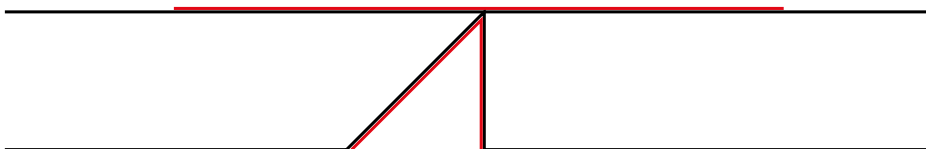

7 Lay top wing face down and glue in the wing struts at 90°. **Use a set square, don't eye it!**

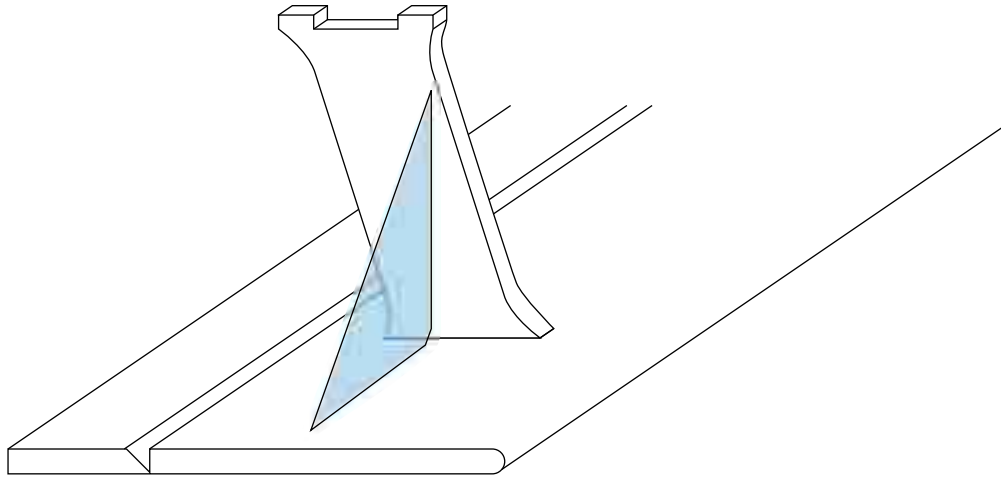

8 Cut out a 6mm wide groove (± 6 mm deep) to insert your 8mm diameter dowel (800mm long). Drag one end of the dowel through the groove to shape it to accept the dowel. Glue dowel in place and cover with 2inch clear tape.

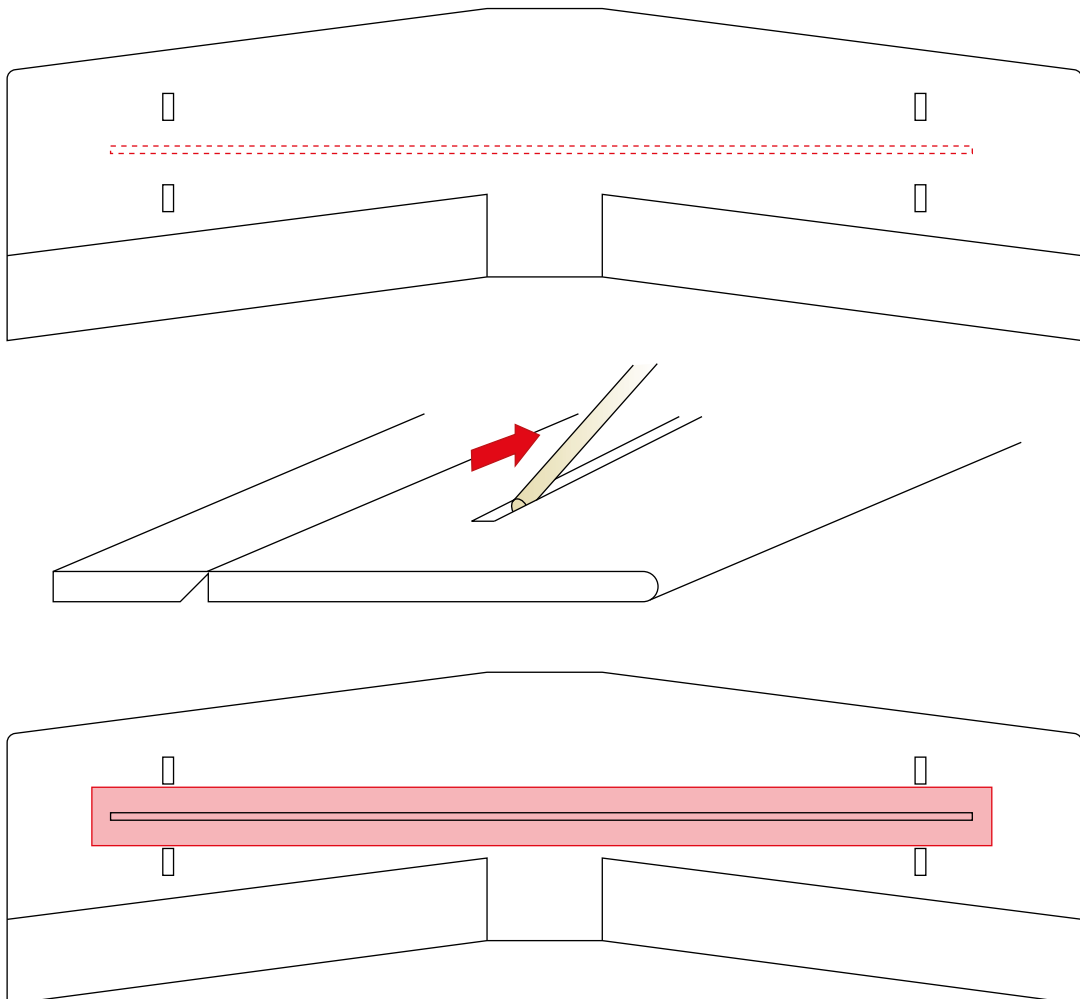

- 9** Now glue the two wings together. Use that set square again! **Make sure the wings are parallel.** Put the wing assembly one side to dry. (Be careful, the top wing is still fairly delicate at this point without any bracing in place.)

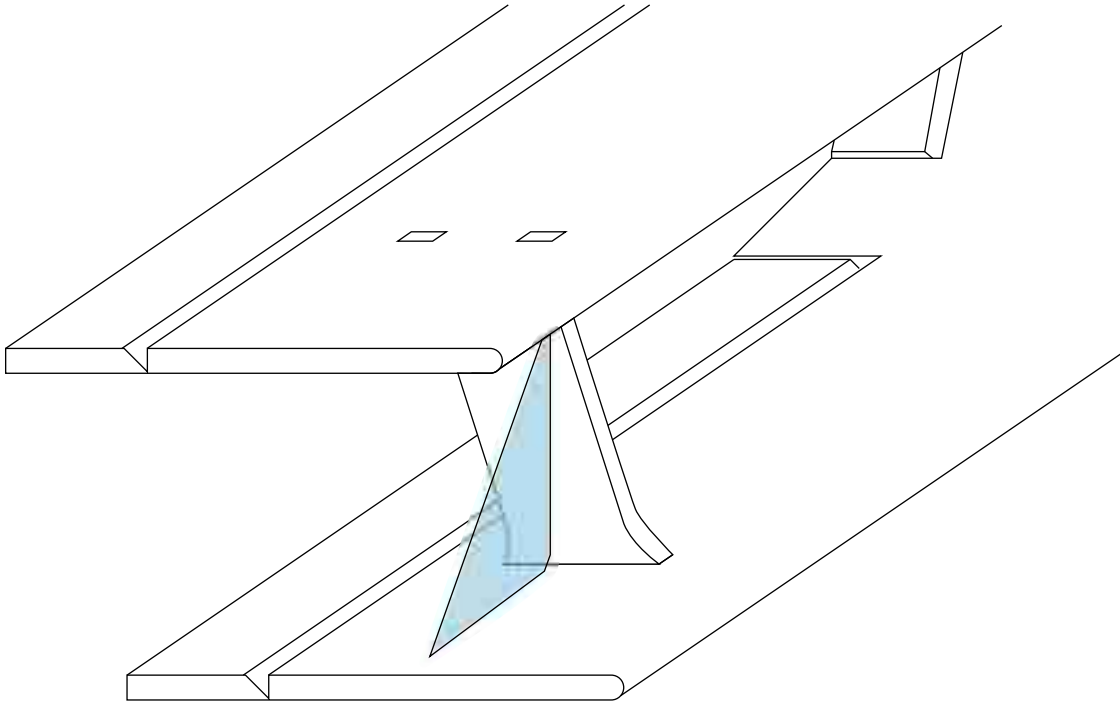

- 10** Mark and cut out one side of the fuselage. Use this side as a template to cut out the other side. (Place it upside down to trace, that way you don't transfer any error from the angle at which you cut out the first side of the fuselage.)

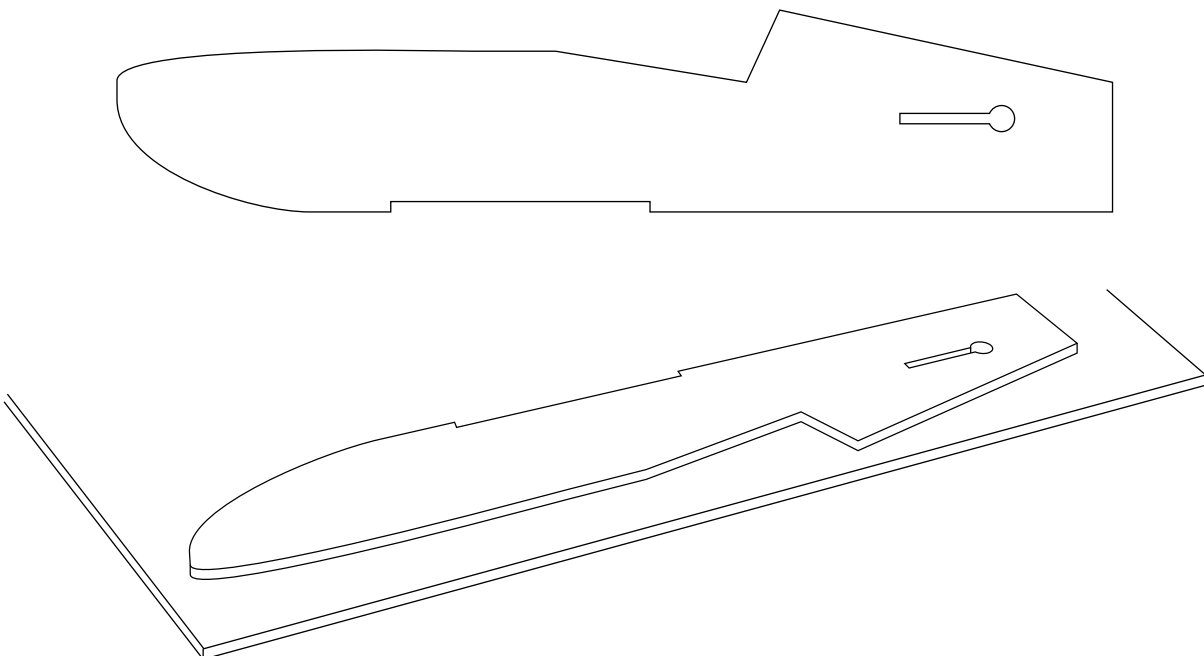

- 11** Now that you have two fuselage panels mark the side that you drew your cut lines on as **inside**. This helps to keep the fuselage true and any error in cutting angle can be sanded out later.

- 12** Cut out all remaining fuselage pieces including the rudder and vertical stabiliser.

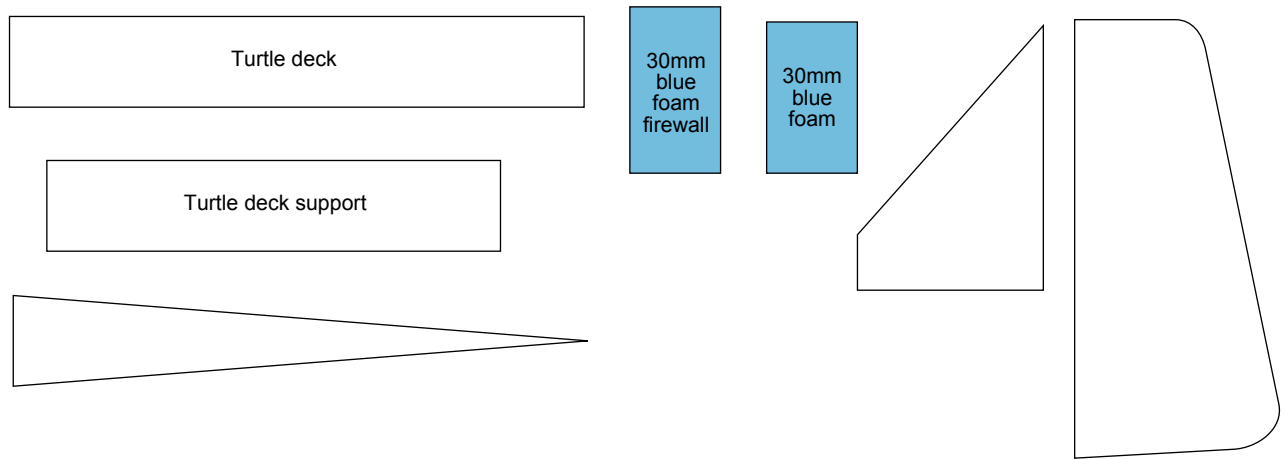

- 13** Slice the inside tail ends of both fuselage panels at an angle 54mm from the centre of the end. Use a new blade in your craft knife and extend it all the way! (Use same method as ailerons.)

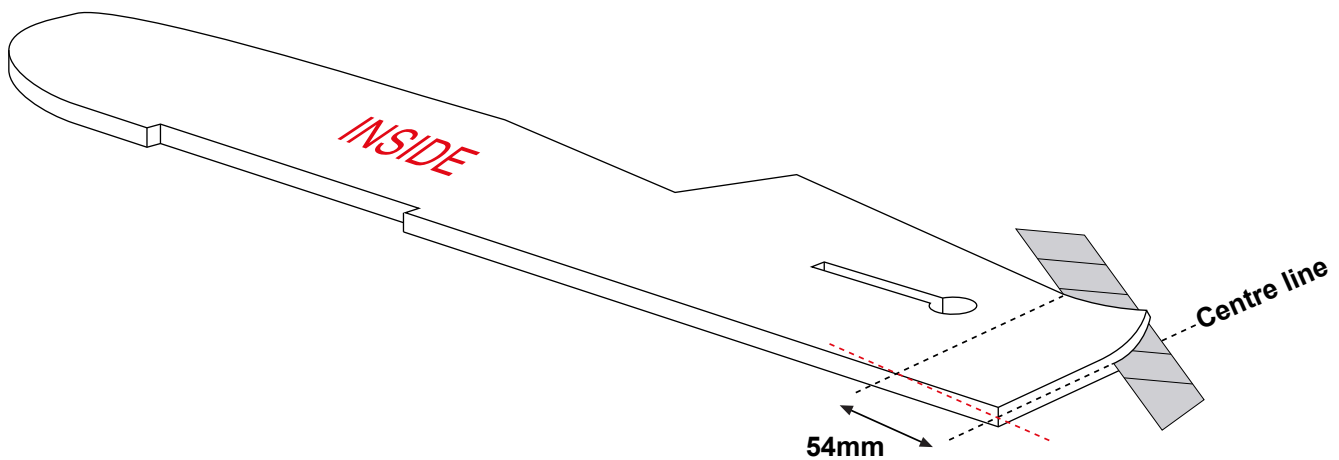

- 14** Draw lines on the inside from the canopy to the point of the tail and also down to the base of the fuselage. Cut a 3mm wide groove about half way through the thickness of both panels from canopy to tail.

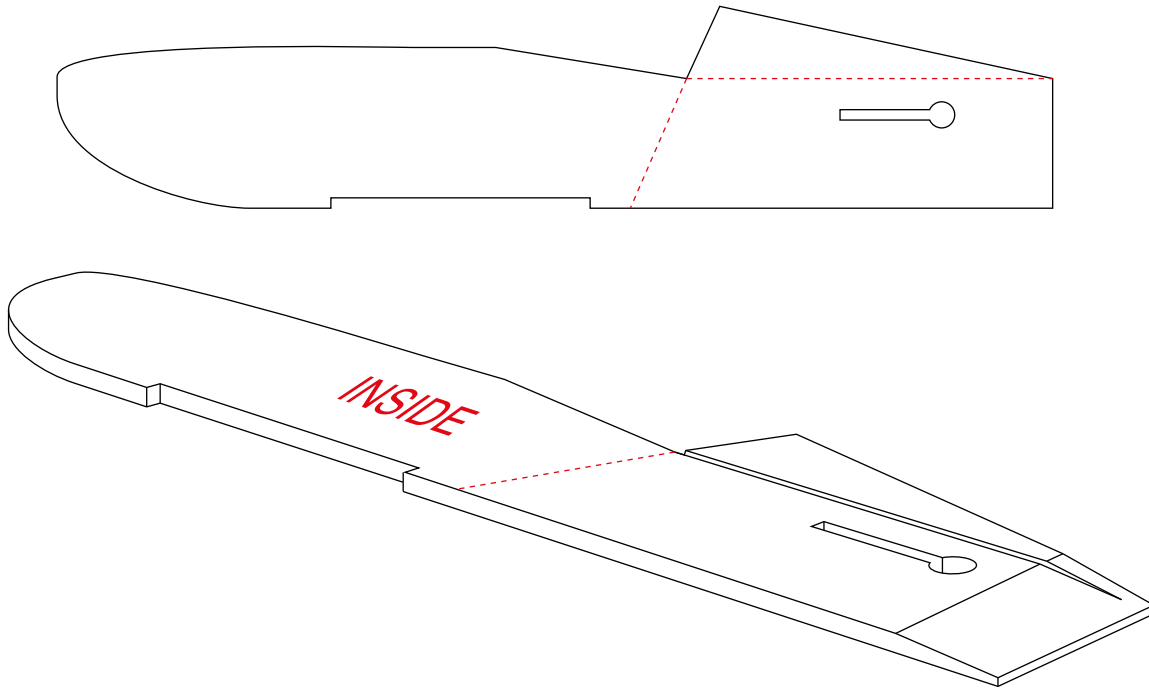

- 15** Carefully pre-bend both fuselage panels along this groove by lifting the bottom of the fuse while keeping the top flat against your work surface. (It won't keep the shape, you just want to get the foam bending in a nice straight line before you glue the two sides together.)

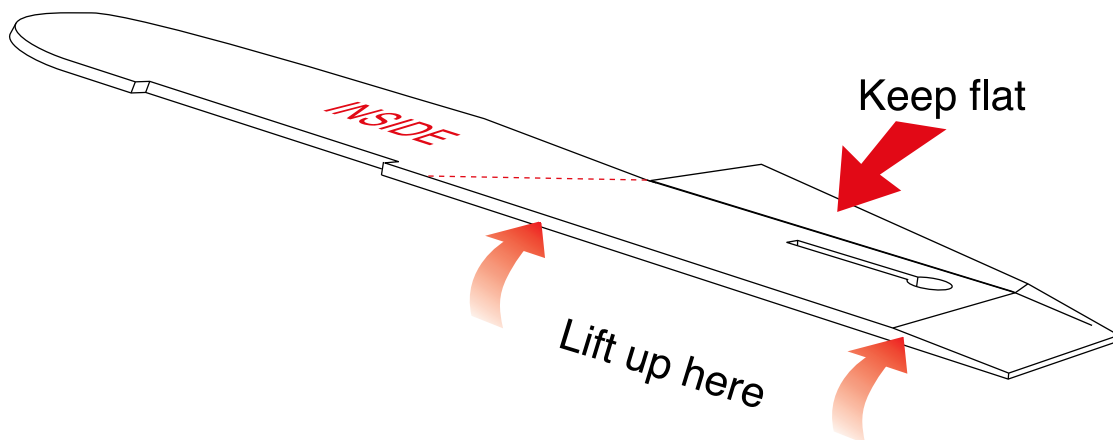

- 16** Draw a line 22mm from the top edge of the fuselage and slice off at an angle. (Do this to both inside sides.)

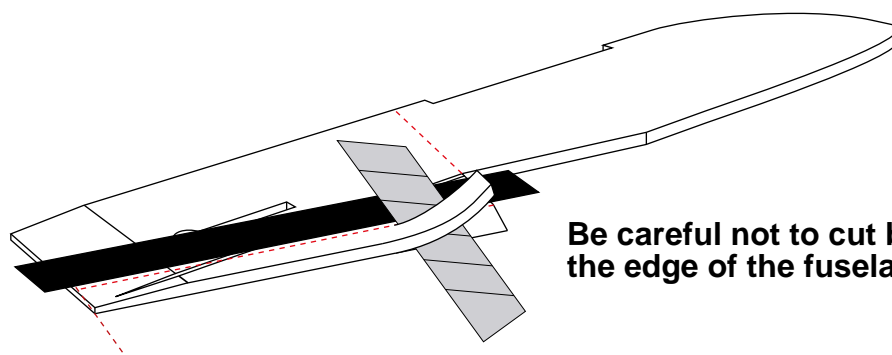
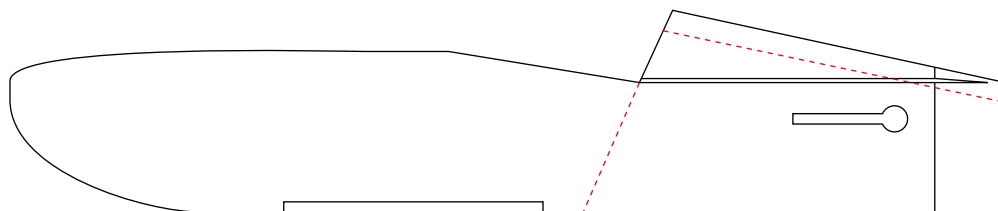

Be careful not to cut beyond the edge of the fuselage!

- 17** Cut out an angular former to these dimensions.

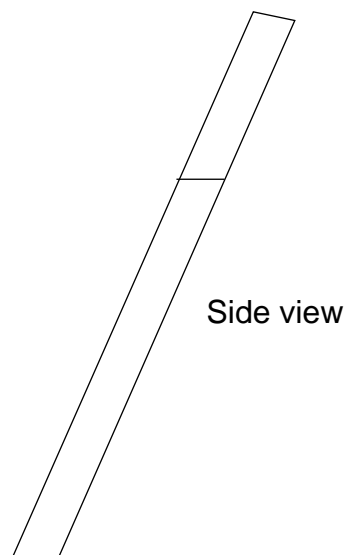
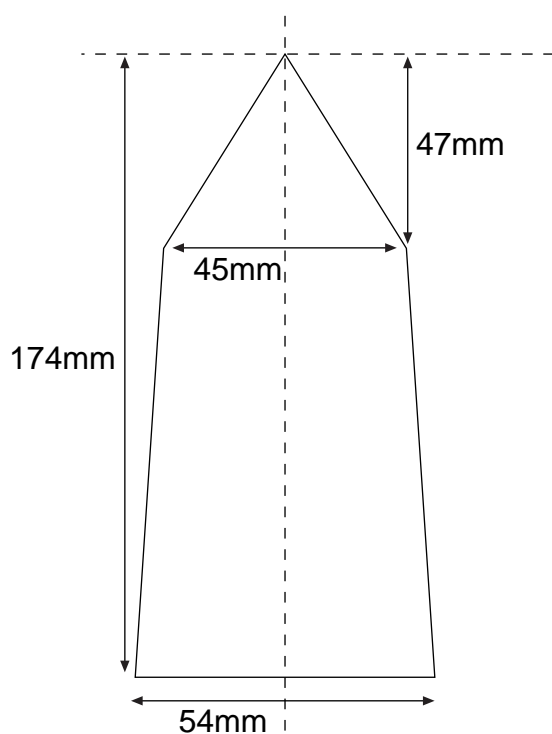

Side view

20

Assemble firewall and turtle deck.

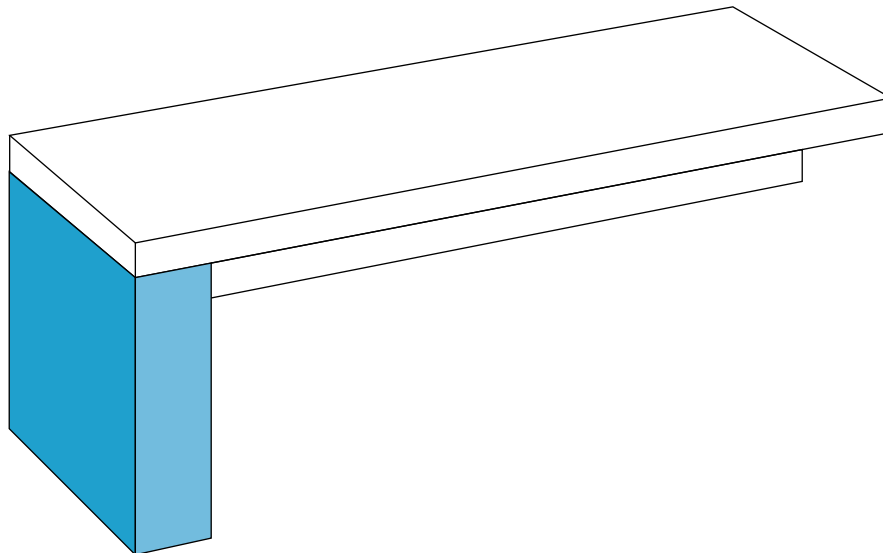

21

Glue turtle deck assembly into place and temporarily secure with tape while glue sets. Be sure to line up turtle deck with the canopy cutout on both sides to avoid a skew fuselage. Protruding edges must be cut and sanded down to fit shape of nose once glue is dry.

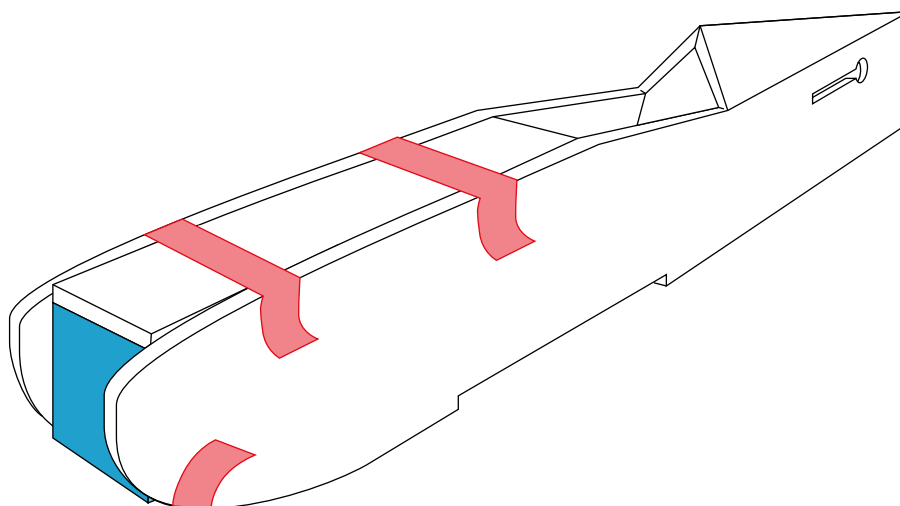

- 22** Assemble base for landing gear.

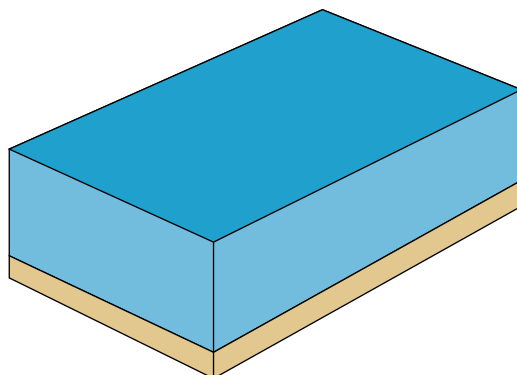

- 23** Glue landing gear base into place and temporarily secure with tape while glue sets. Be sure to line up the landing gear base with the cutout for the wing on both sides of fuselage.

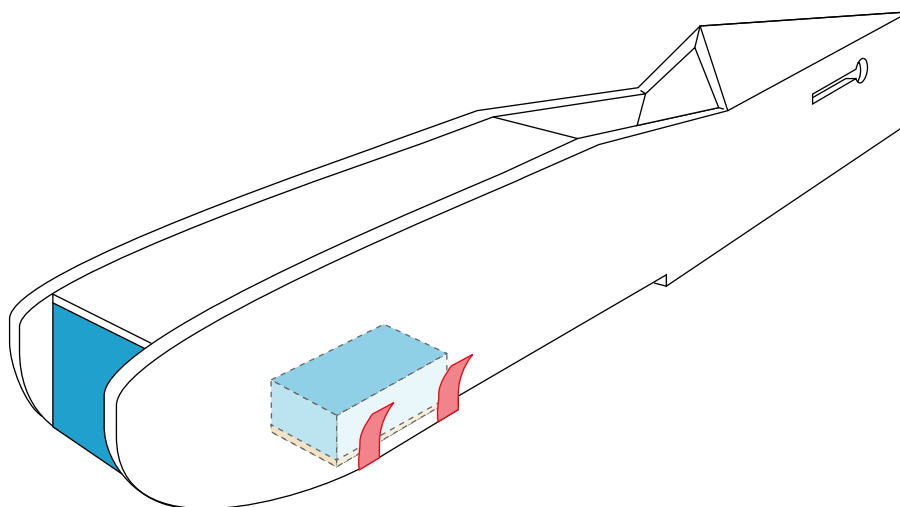

- 24** Cut 45° bevel edges on both sides of rudder along centre line and glue in three polycarbonate hinges. (You can use any suitable plastic as a hinge.)

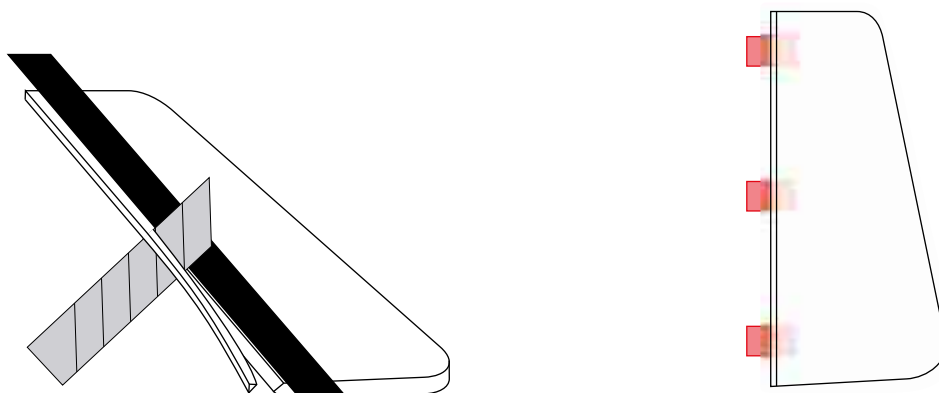

- 25** Cut out groove in fuselage to accept the vertical stabiliser.(10mm wide.)

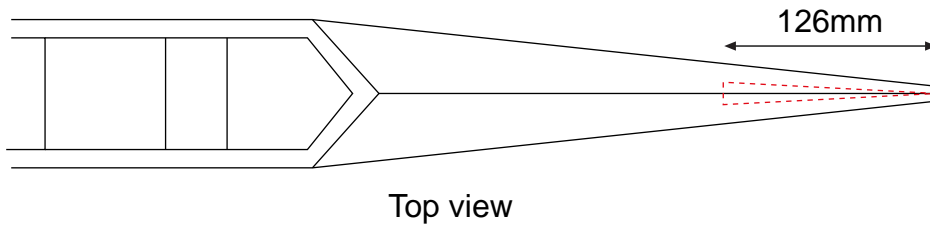

- 26** Glue vertical stabiliser in place making sure it is square and straight with a straight edge of your ruler. Seal joint with 2inch clear tape.

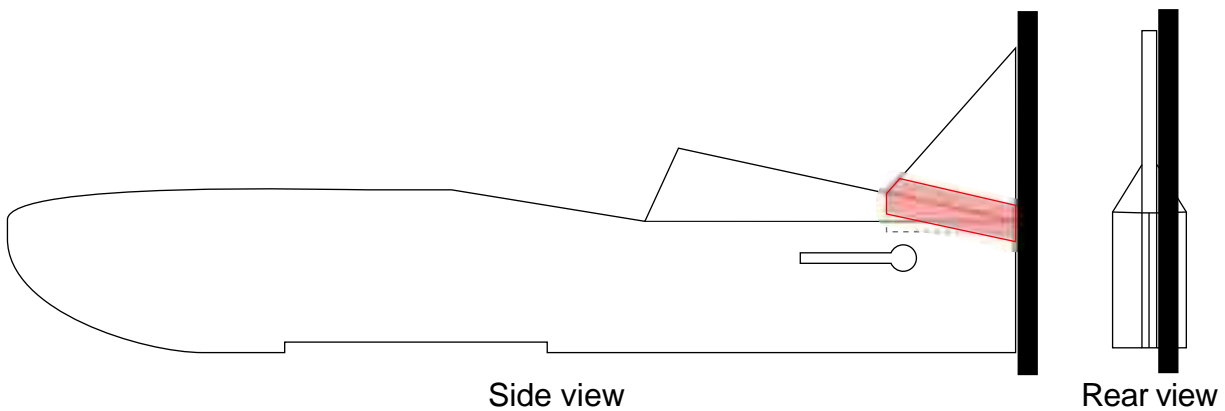

- 27** Cut slits along centre line of vertical stabiliser to accept rudder hinges and glue rudder in place. When dry, seal rudder joint with half inch clear tape on both sides.

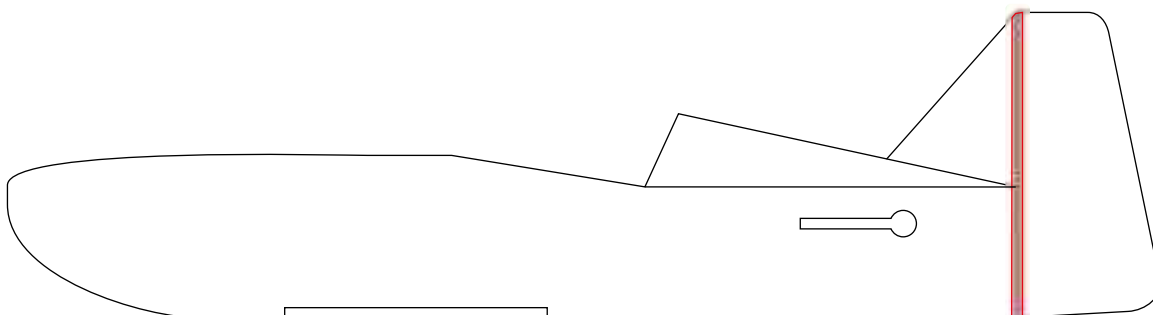

- 28** Mark the centre inside the fuselage and on the trailing edge of the landing gear base.

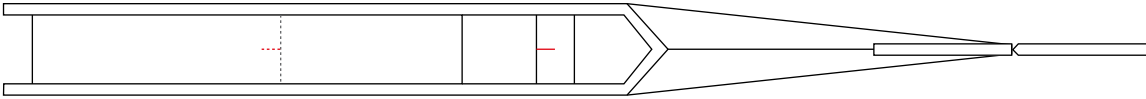

Top view

- 29** Mark the centre on the top side of the lower wing. Use these centre lines to glue wing in position.

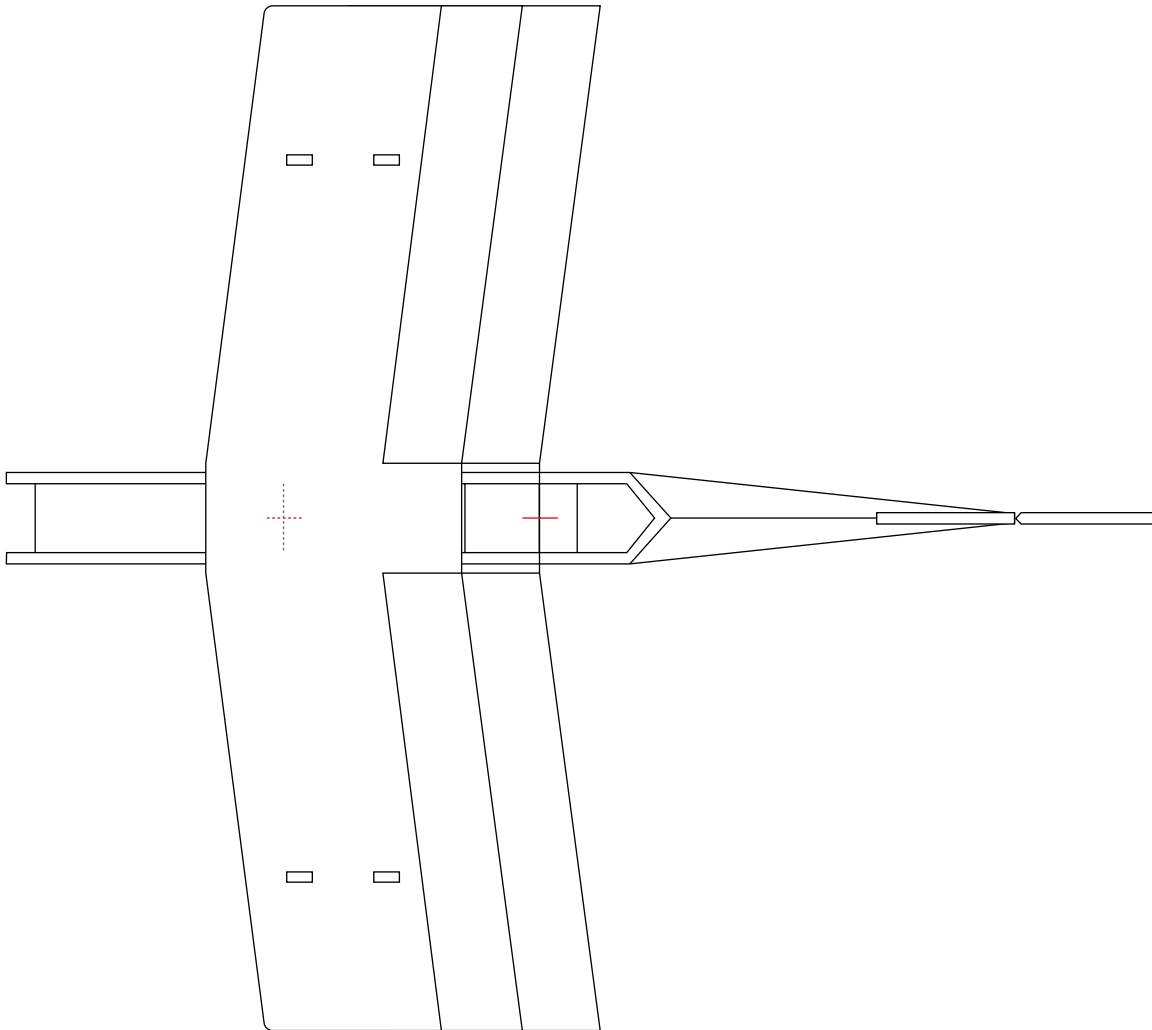

- 30** Place a long straight end on the top wing and pack waste material between the top wing and the turtle deck until the top wing is straight with no sag.

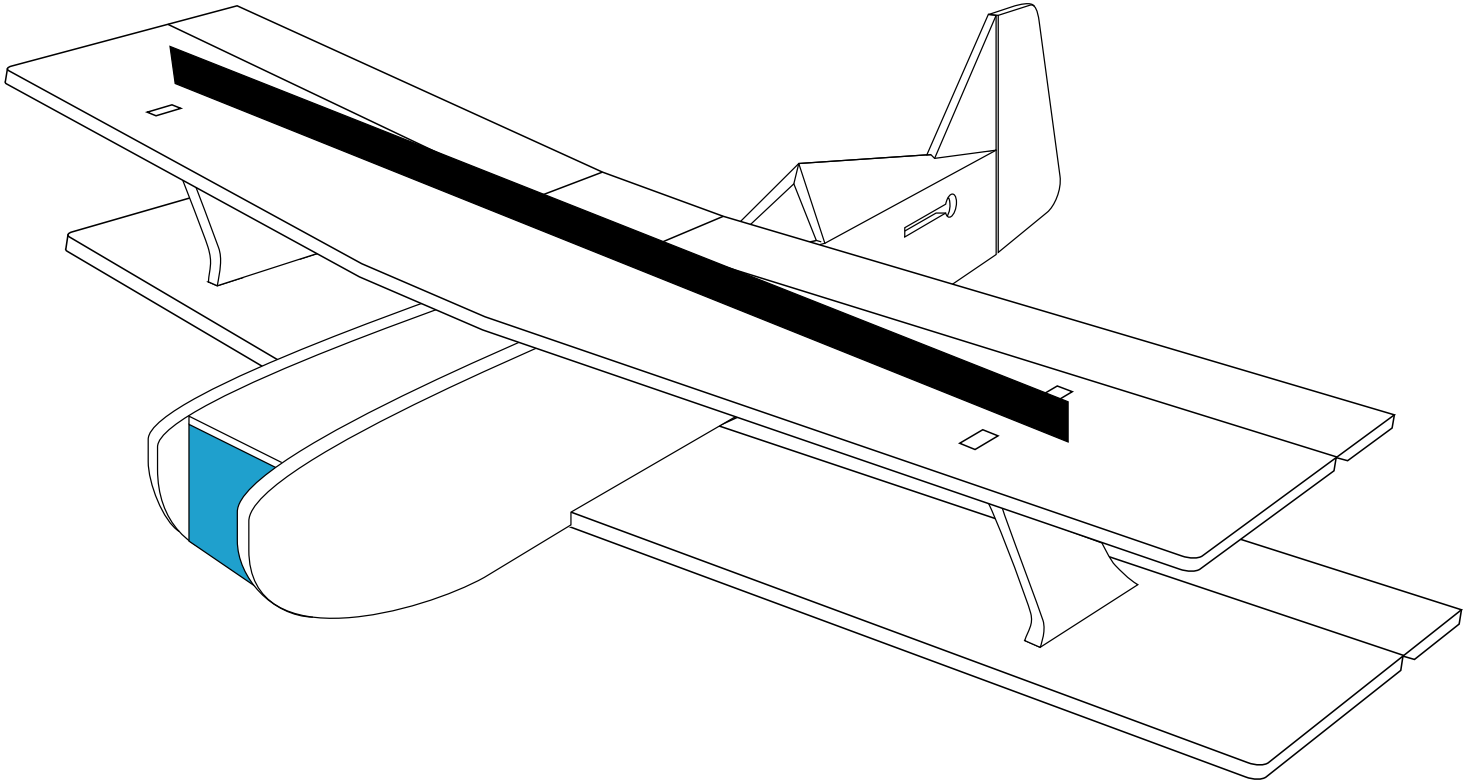

- 31** Insert six bamboo skewers through top wing and into both layers of the turtle deck. (Twisting the skewer as you press helps to make a neat hole.) The measurements here are no critical, but the wider the angle, the stronger the joint will be. Once you are happy with the positions of your skewers, remove and glue them in place one at a time. Use a liberal amount of glue to create a bead around the bamboo skewer. Keep that set square handy to make sure the wing does not go out of square during this process.

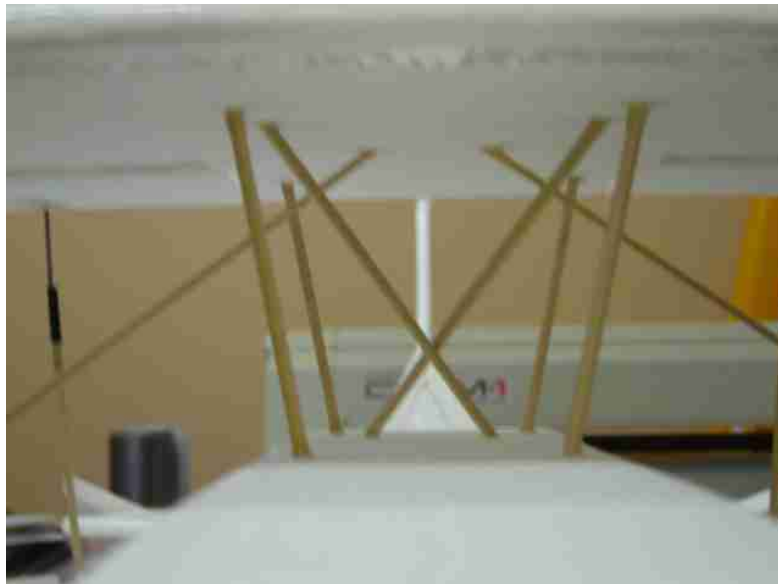

32 Glue the wing braces into position (1.5mm dowel) Tie with cotton and secure with CA

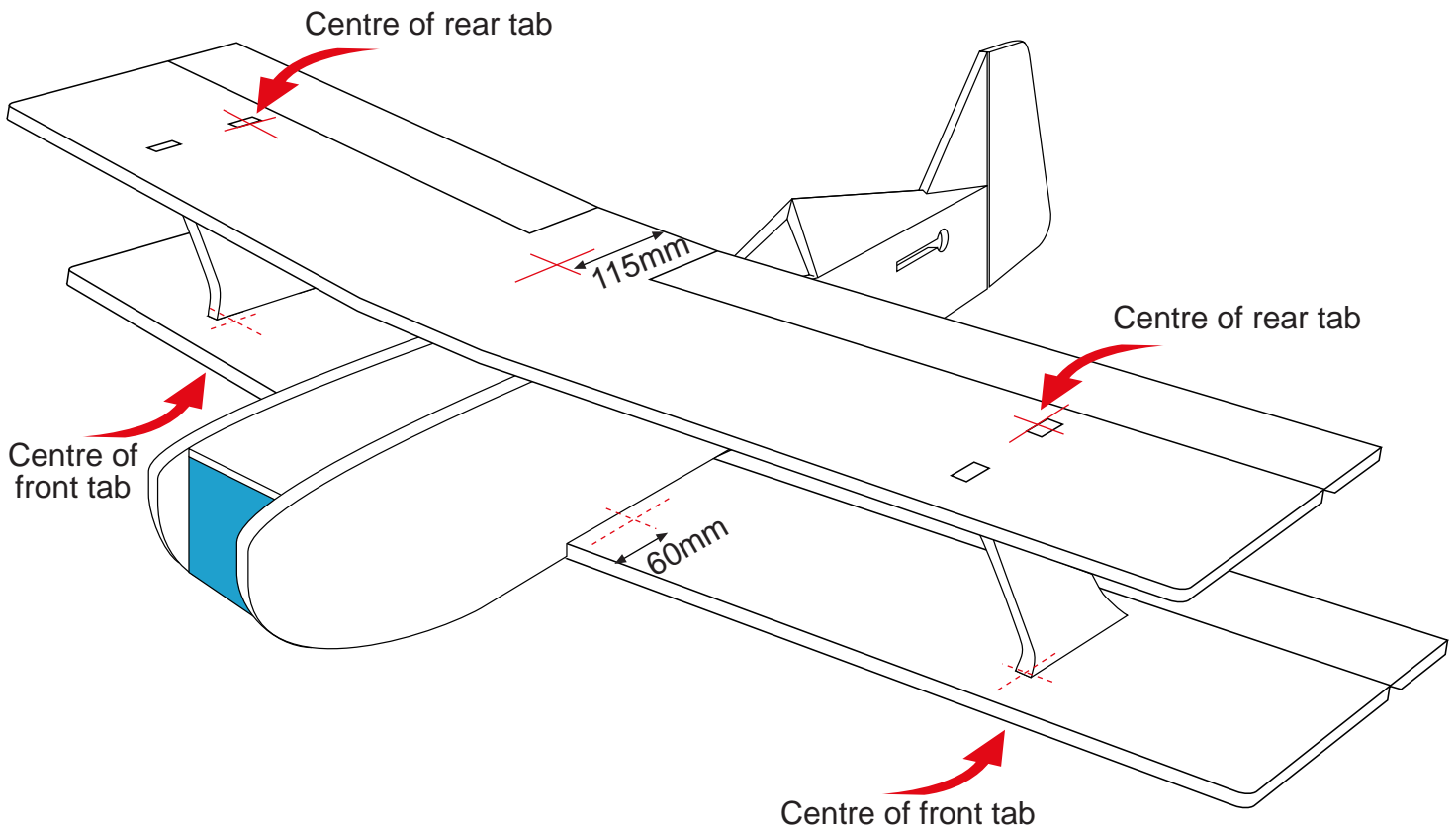
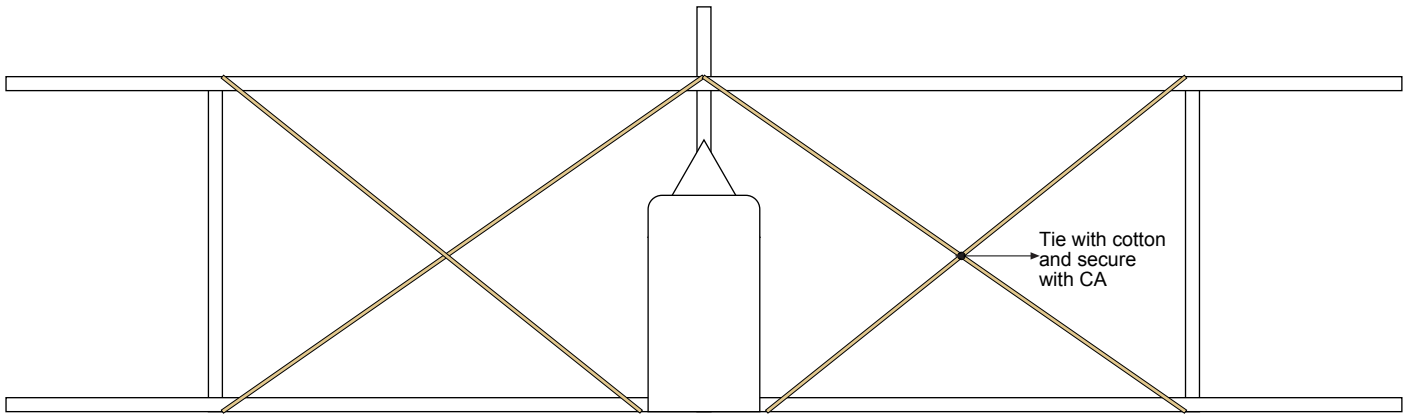

Once all of the bracing is glued in position your wing should be pretty rigid. If it is not you have not braced it correctly, check your joints for firmness.

- 33** Cut out the horizontal stabiliser and elevators

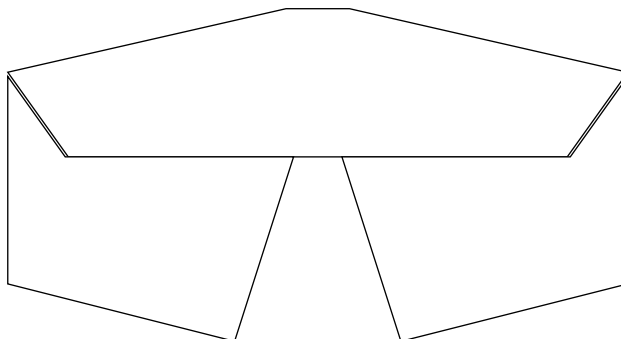

- 34** Notch the elevators to accept a 120mm long x 10mm square balsa stick

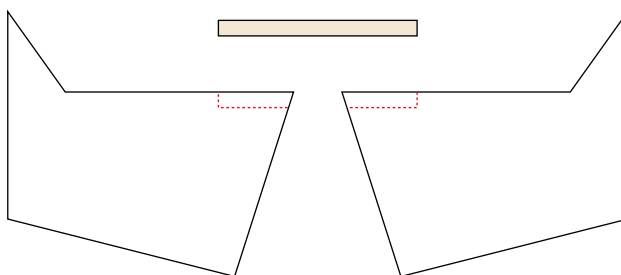

- 35** Glue the square balsa stick to only one elevator.

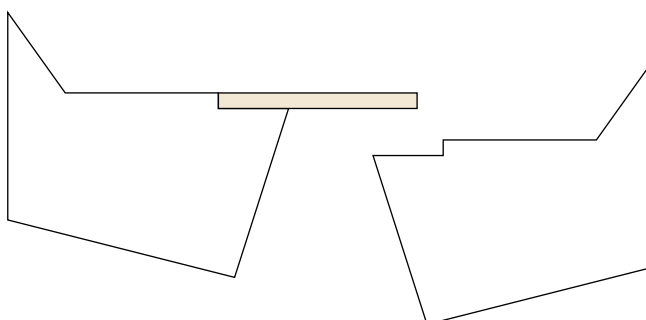

- 36** Using the same "table" method as before, cut a 45^a bevel on the bottom edge of both elevators.

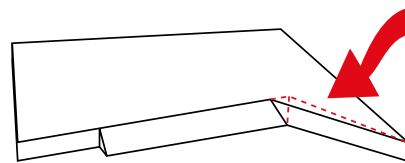
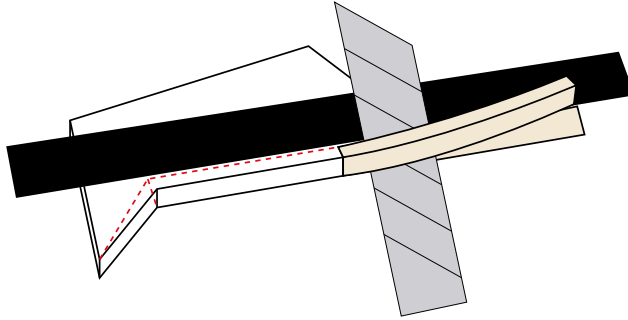

Bevel this edge a little too to stop the elevator binding.

- 37** Hinge the elevator with the balsa stick to the horizontal stabiliser with 2inch clear tape using the same method as for attaching the ailerons (Top and bottom.)

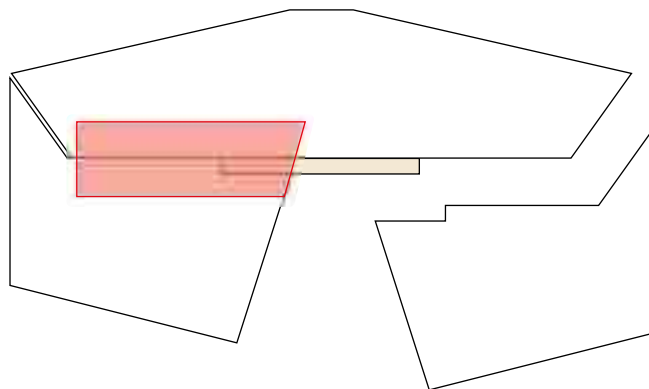

38 Glue elevator assembly into fuselage making sure it is square and horizontal.

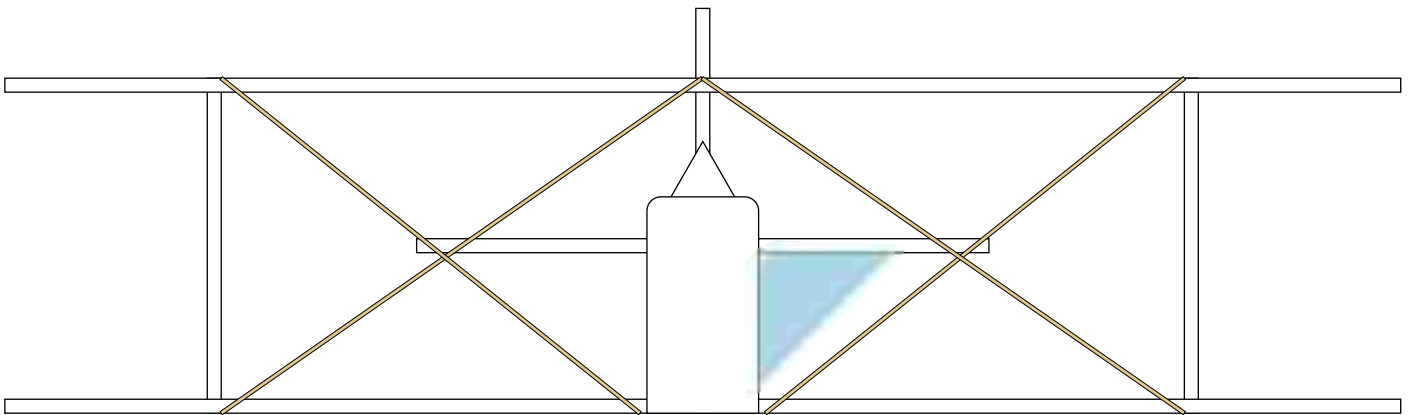
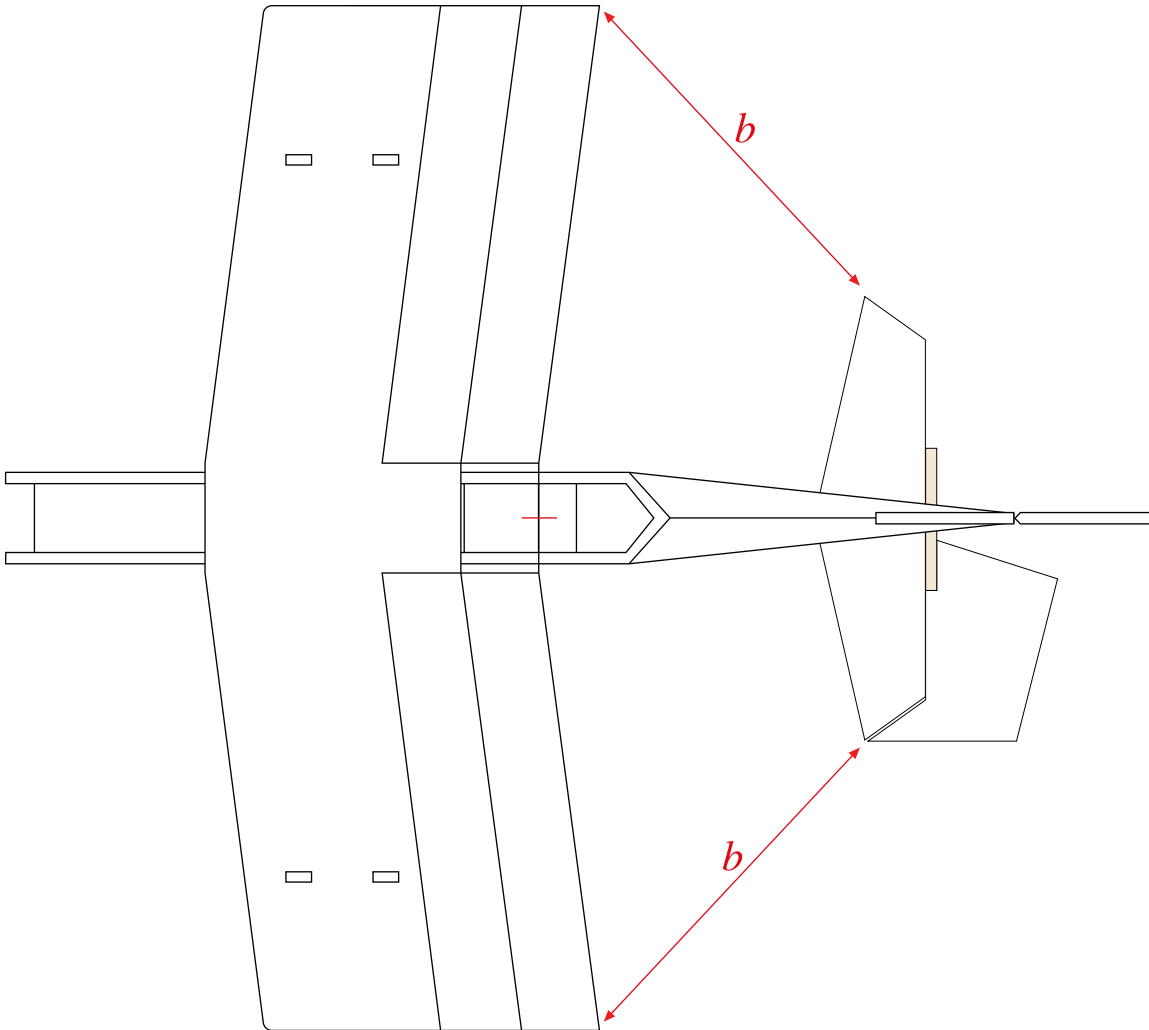

- 39** Temporarily tape the elevator to the horizontal stabiliser on top and bottom to keep it straight. Now glue the other side of the elevator to the balsa stick and temporarily tape it to the horizontal stabiliser while the glue sets, make sure it is perfectly level.

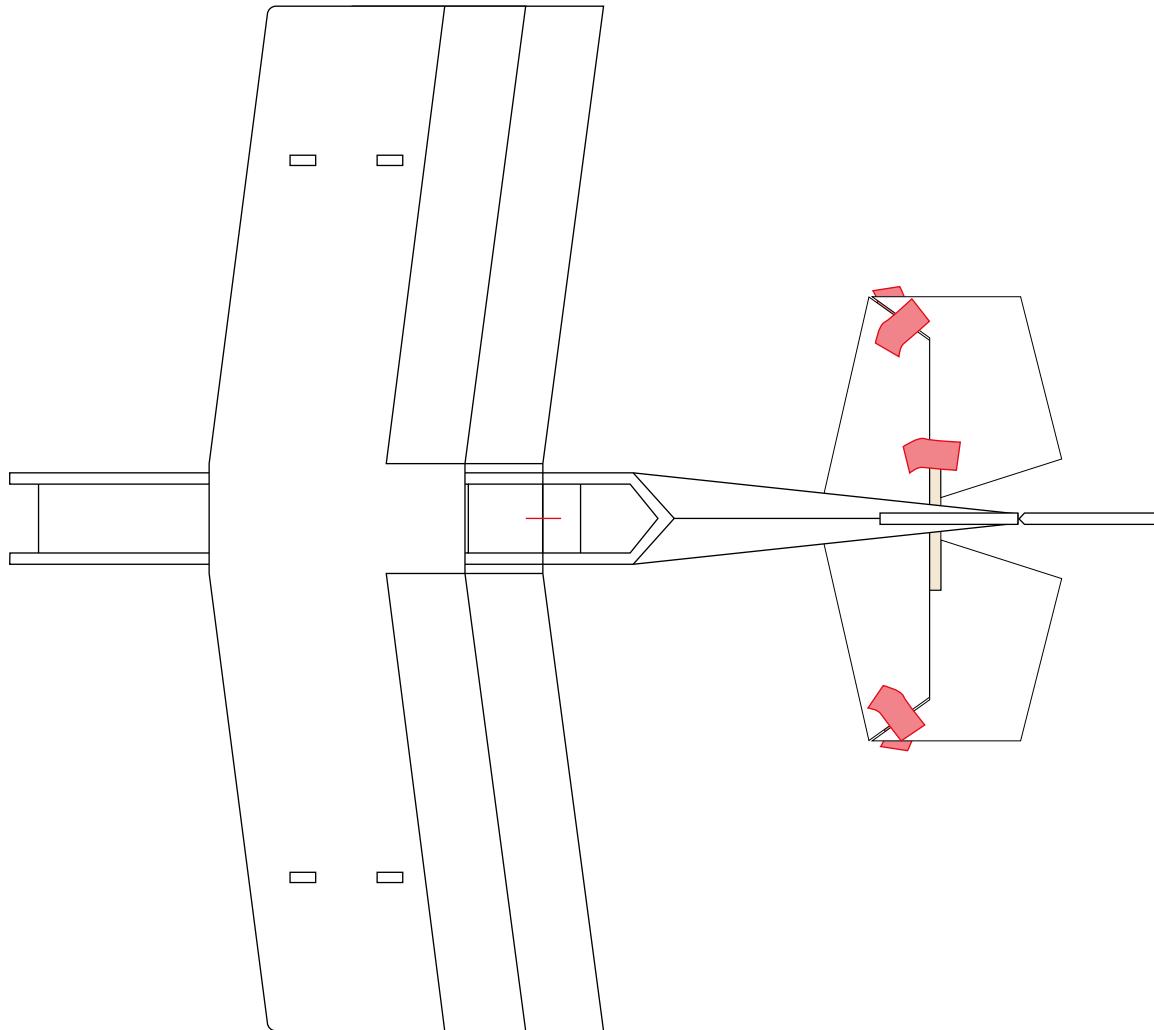

- 40** When the glue is set, hinge elevator to horizontal stabiliser with 2inch tape. (Same as aileron hinge, tape top and bottom.)

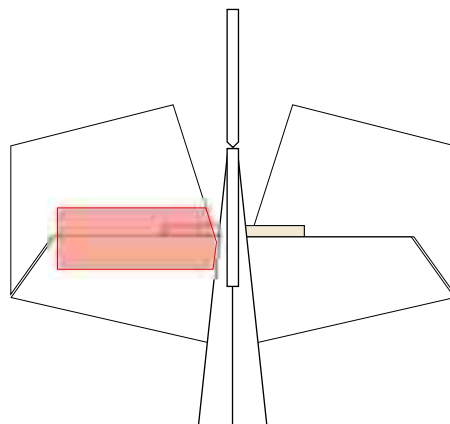

41

Your Big Flat Ultimate is almost complete. You just need to attach control horns, linkages and your electronics. You also need to manufacture a landing gear. Use the following pictures to see how I connected all the flight surfaces and what my LG looks like. If you want to take the trouble, you can even make your Big Flat Ultimate a set of wheel pants.

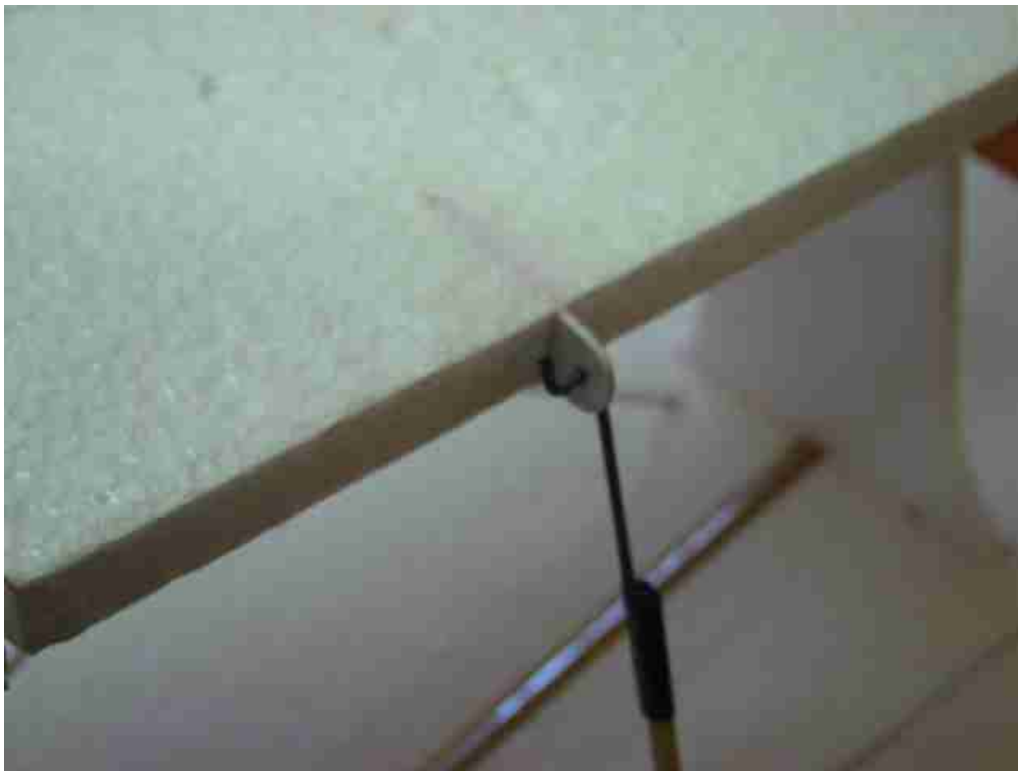

DemonGti's **Big Flat Ultimate**



DemonGti's ***Big Flat Ultimate***

