

MAKE FAN BLADES IN ONE LONG STRIP. DAMPEN & CURVE SIMILAR TO FUSELAGE SHELLS. USE HEAT TO DRY & RETAIN CAMBER. CUT BLADES SLIGHTLY OVERSIZE. GLUE TO HUB WITH EPOXY. TRIM OFF BLADES & CAREFULLY BALANCE. FUEL PROOF.

ENGINE MOUNT & WING PLATFORM DETAIL

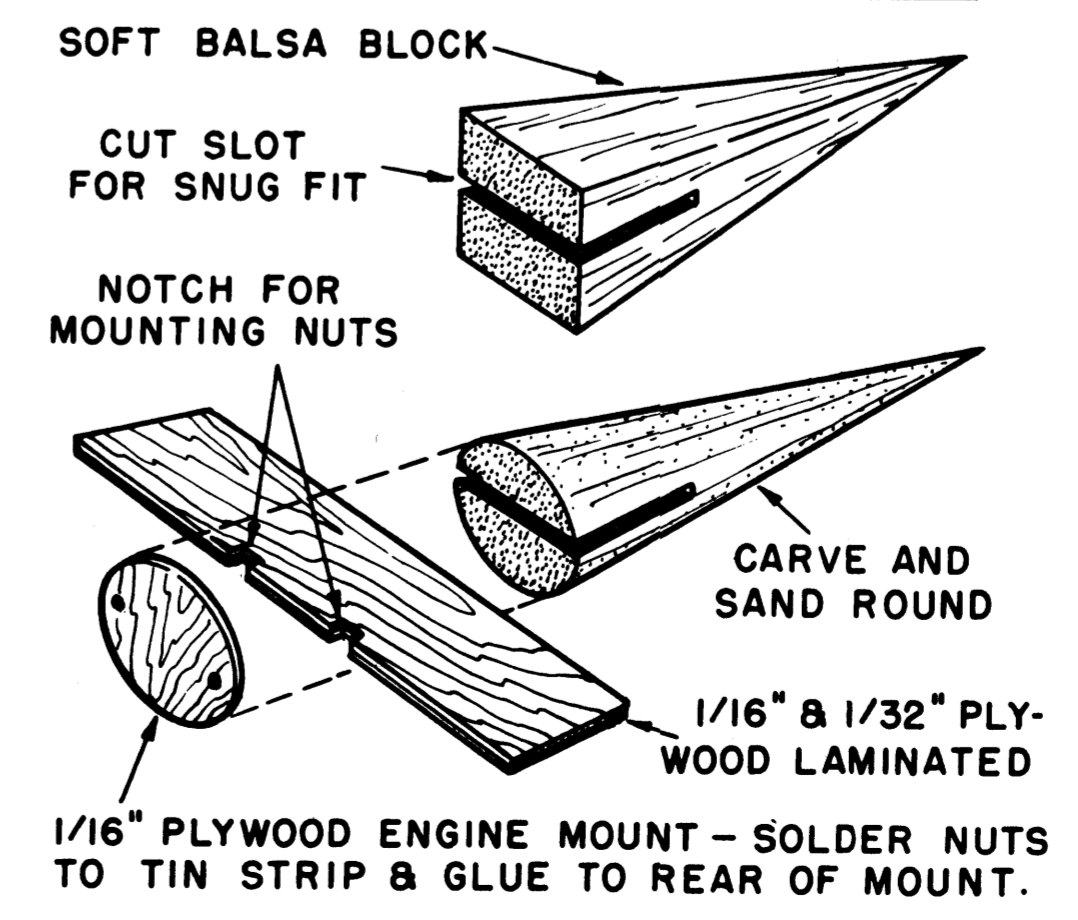

DUCTED FAN SHRIKE

Copyright 1964
The Conde Nast Publications Inc.

