

equipment shown
Vapor receiver
PZ 8.5mm motor unit
160 mAh battery

**Peter Rake's
Spearpoint**
Copyright P. Rake 2013

unless stated otherwise
all wood is 1/16 balsa
by size or shape shown

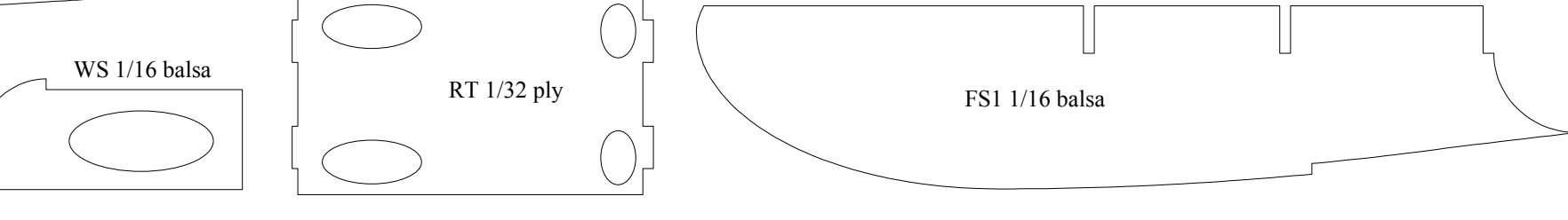

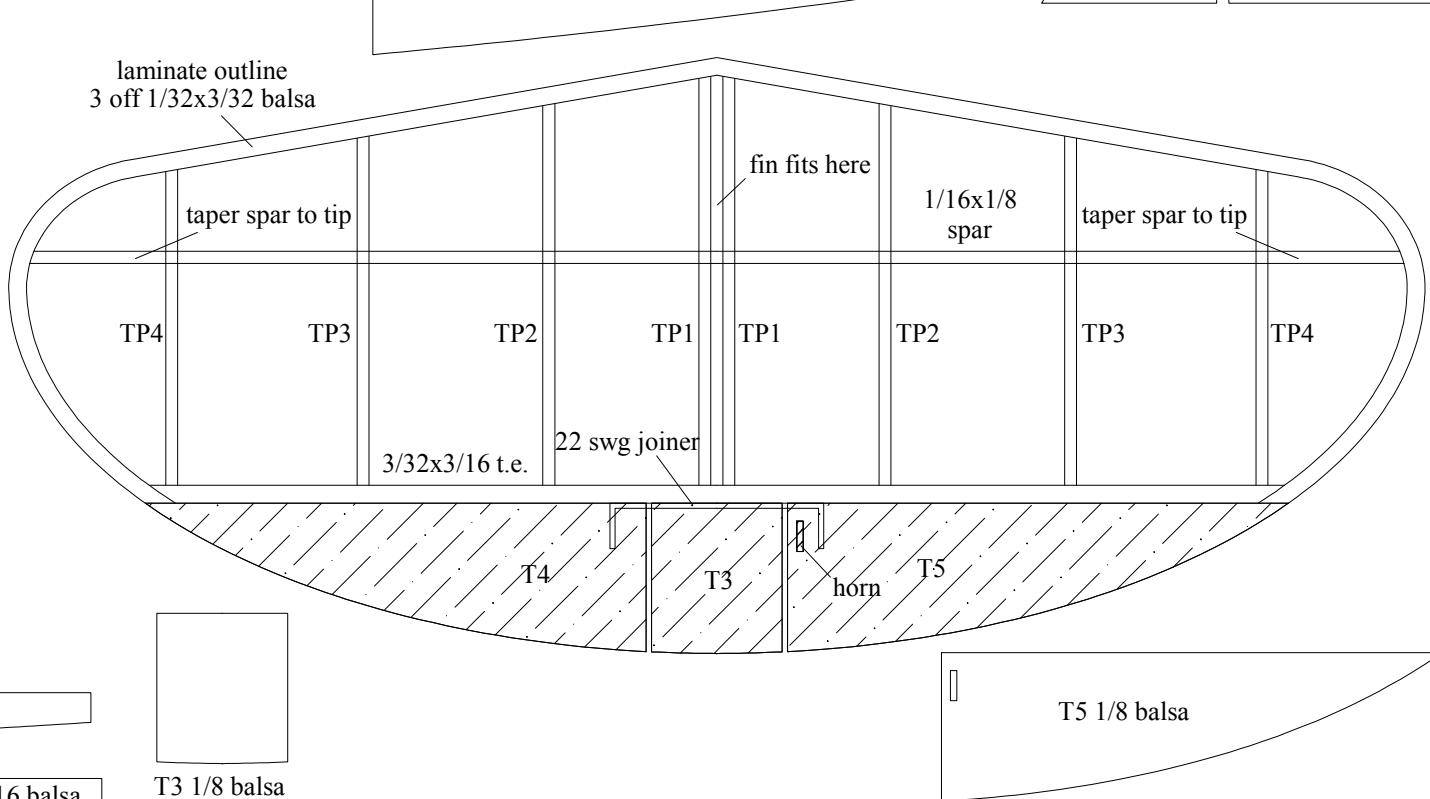
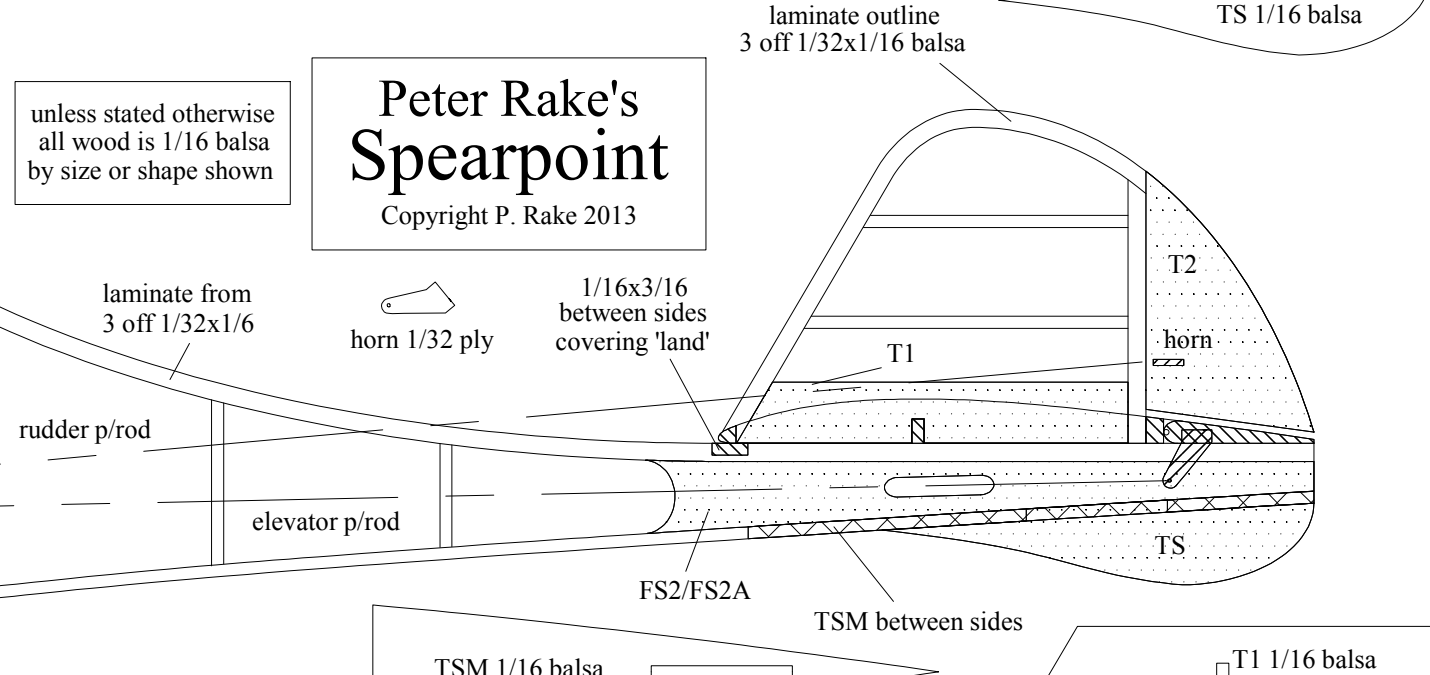
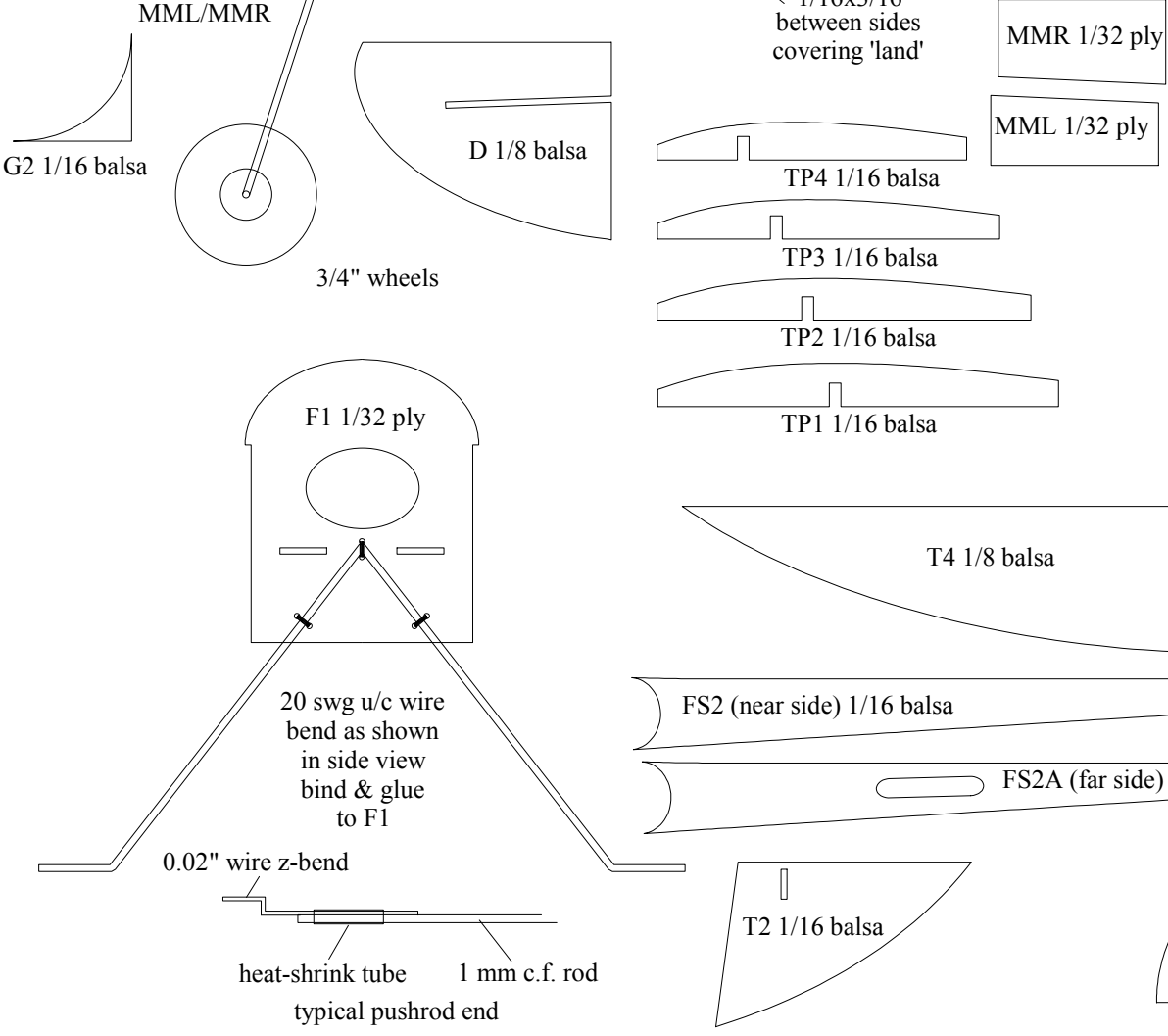
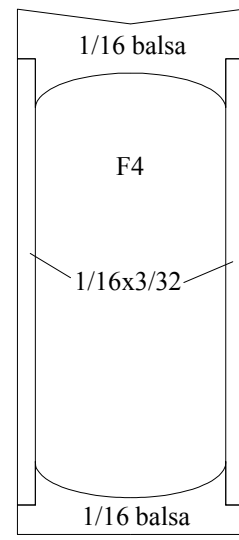
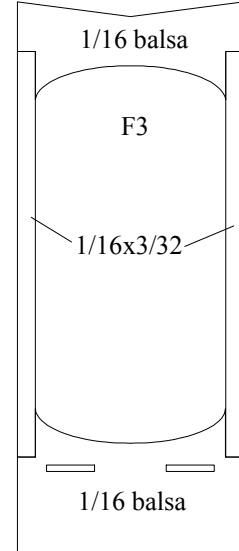
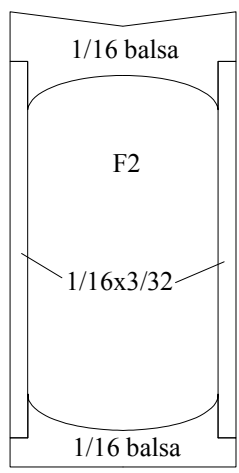
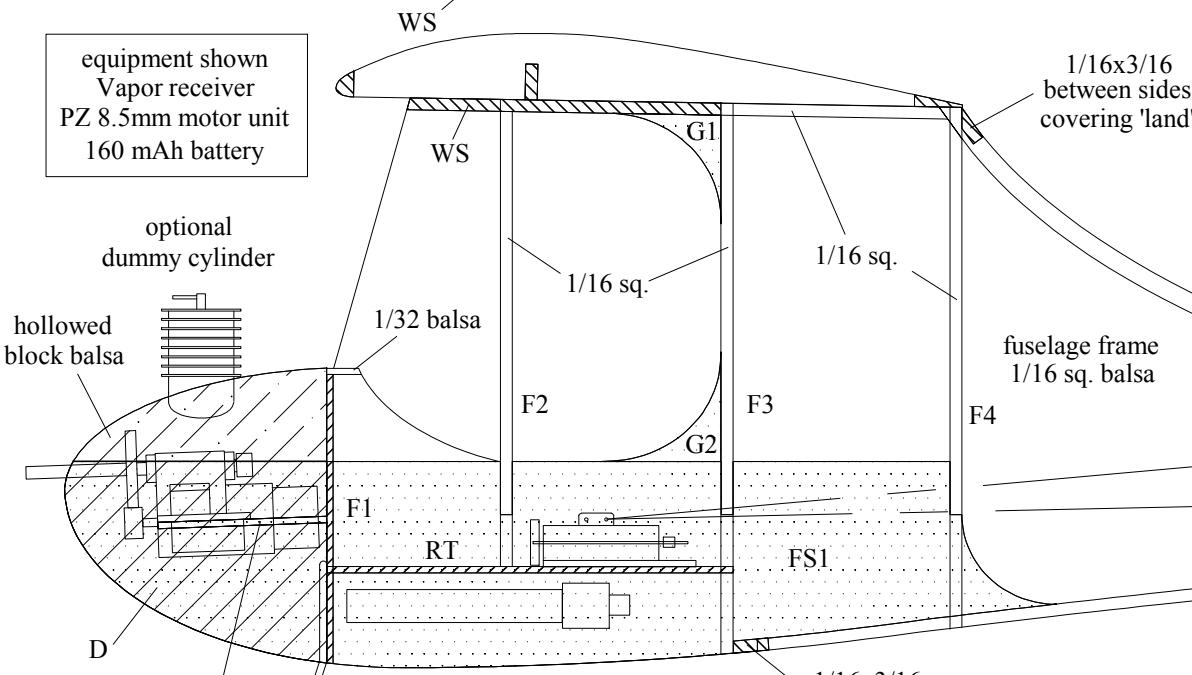
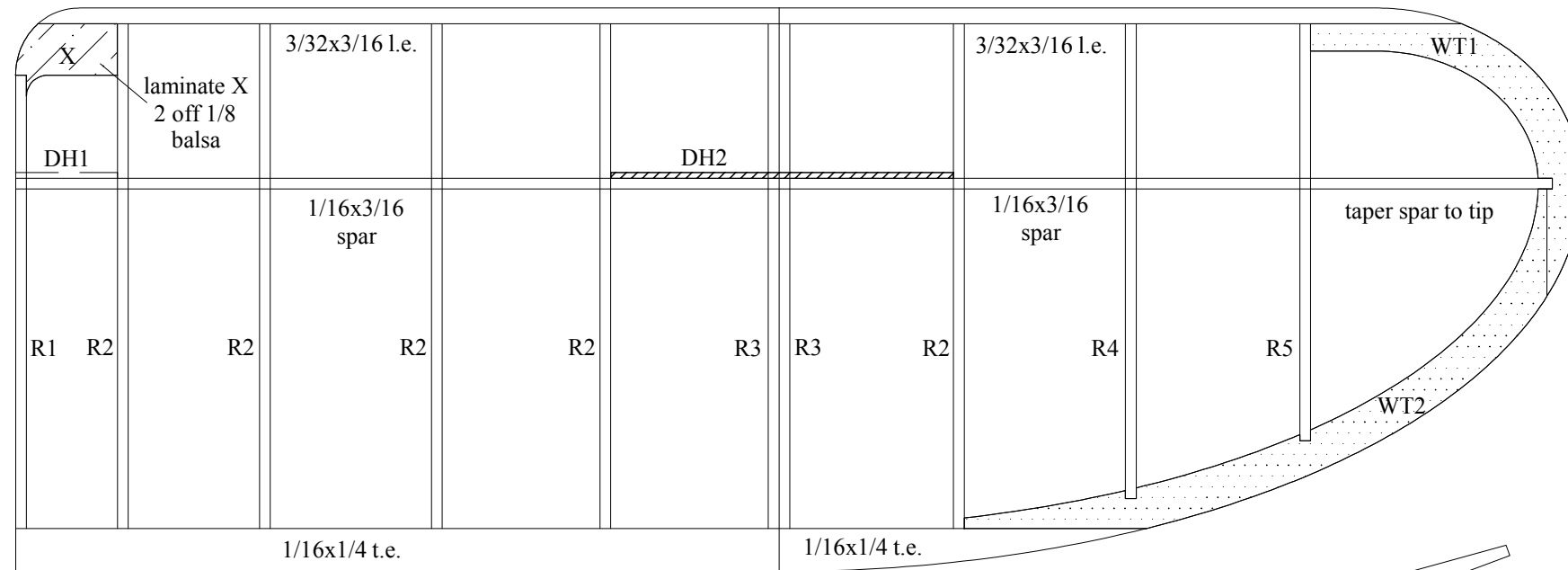
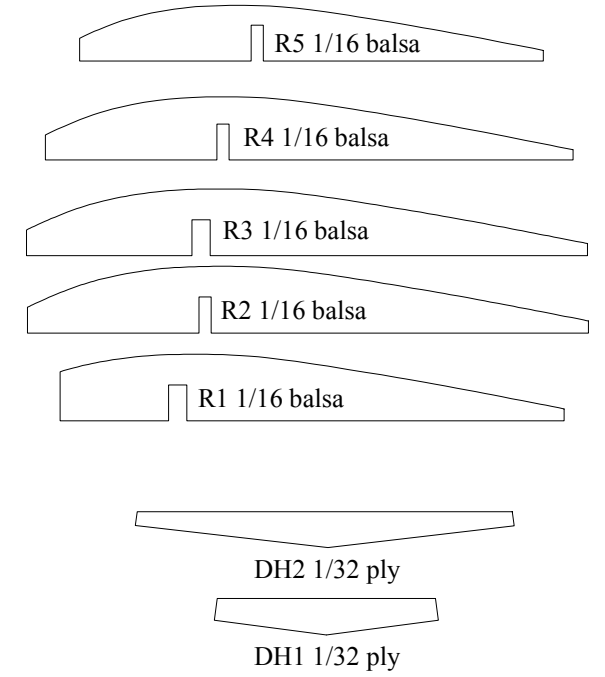
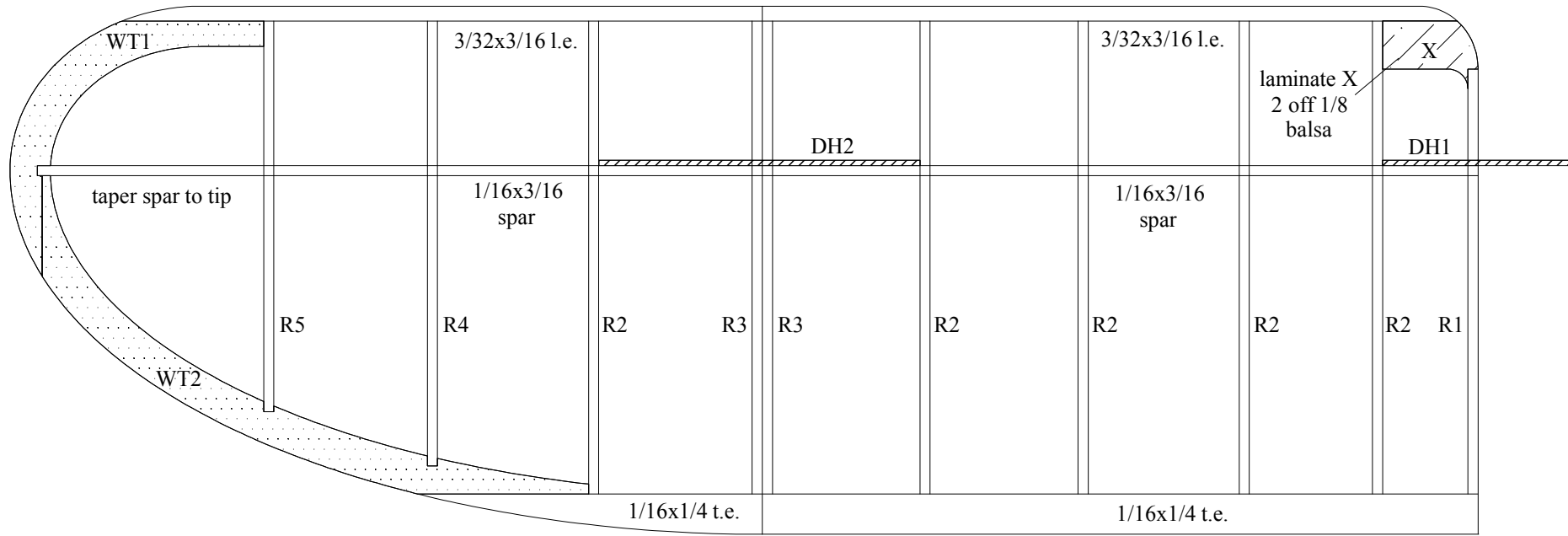

**Peter Rake's
 Spearpoint**
 Copyright P. Rake 2013

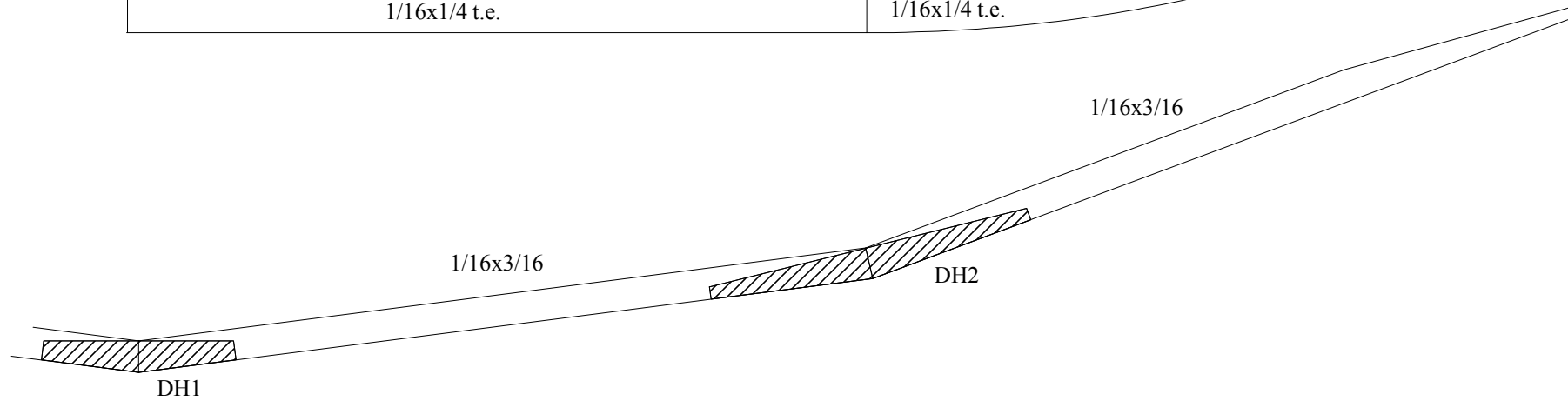
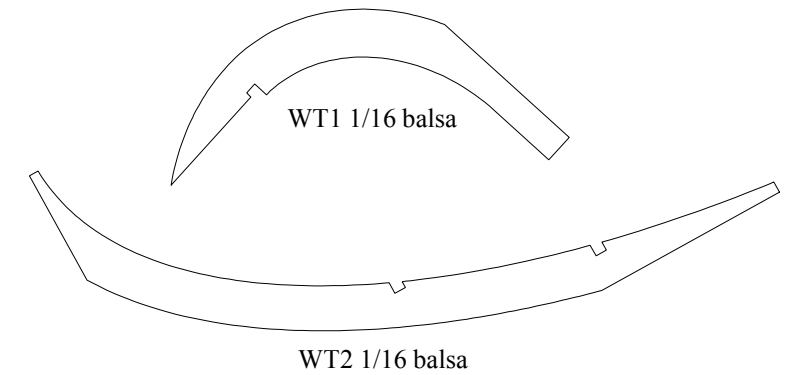
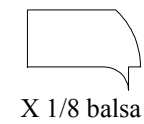

unless stated otherwise
 all wood is 1/16 balsa
 by size or shape shown

wing construction
 assemble complete spar over drawing
 build centre panel over plan
 angle inner and outer ribs
 to match spar joints
 lower spar over tip panel
 build that panel
 repeat for opposite wing