

equipment shown
Vapor Rx brick
PZ 8.5mm motor unit

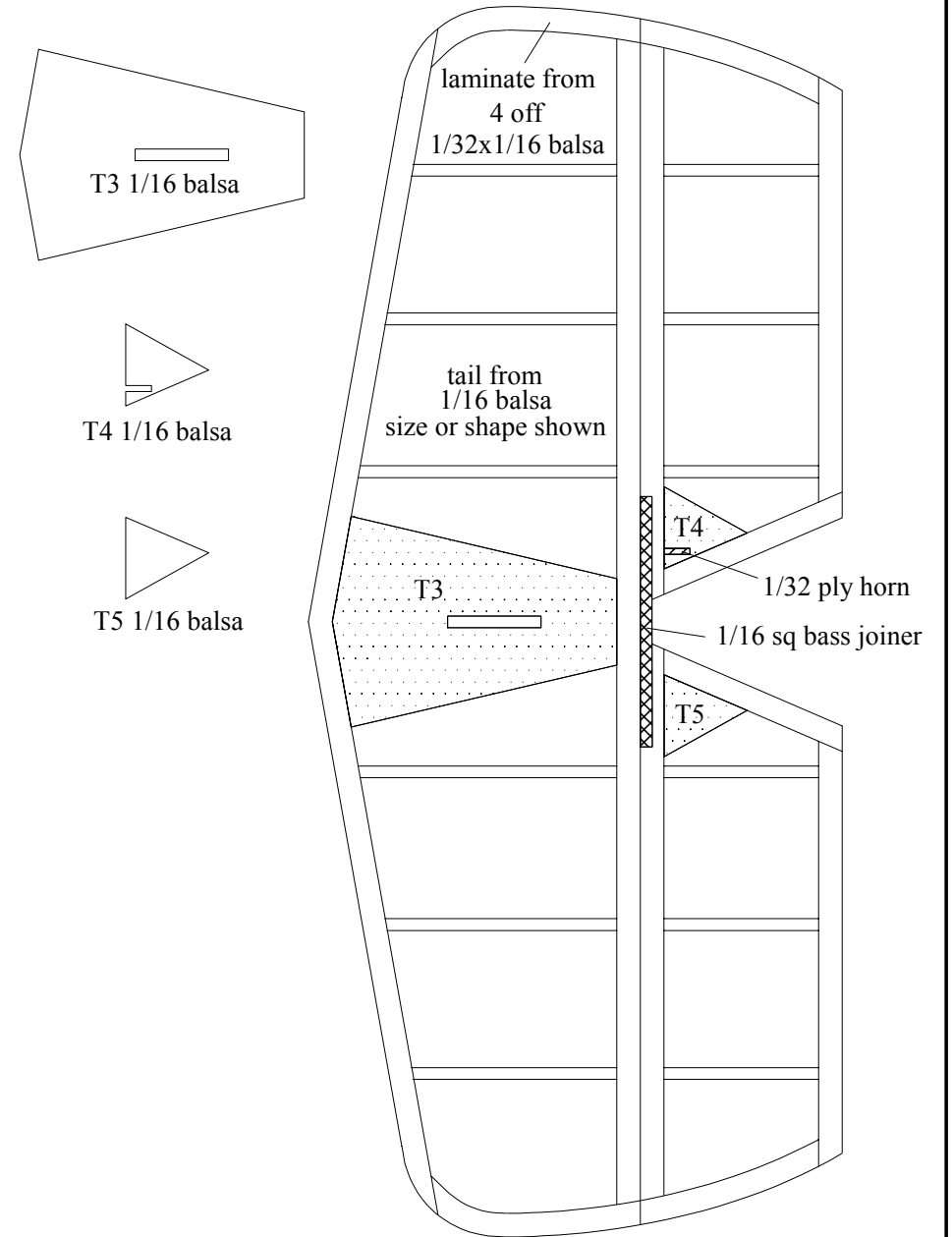

Peter Rake's
Martin MO-1
Copyright P. Rake 2015

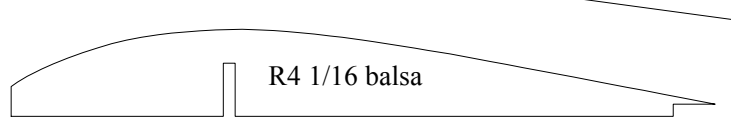
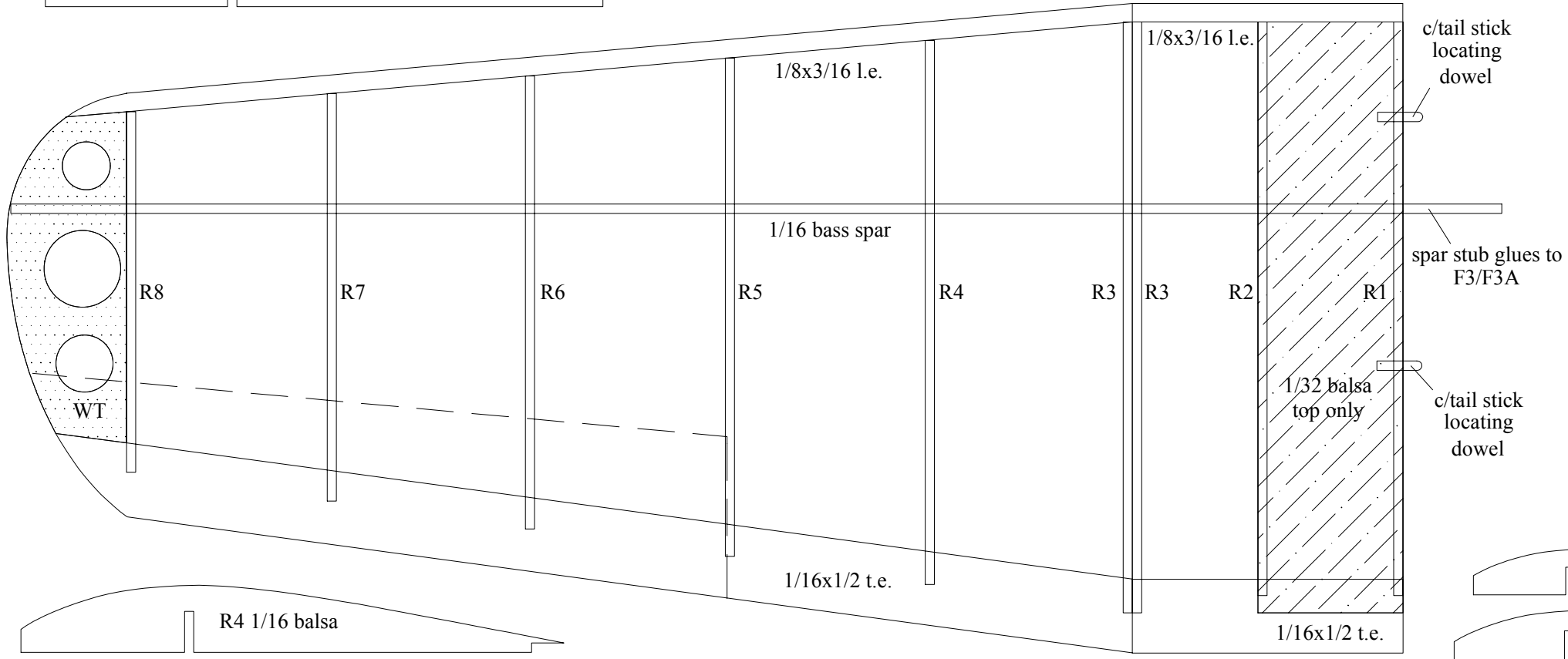
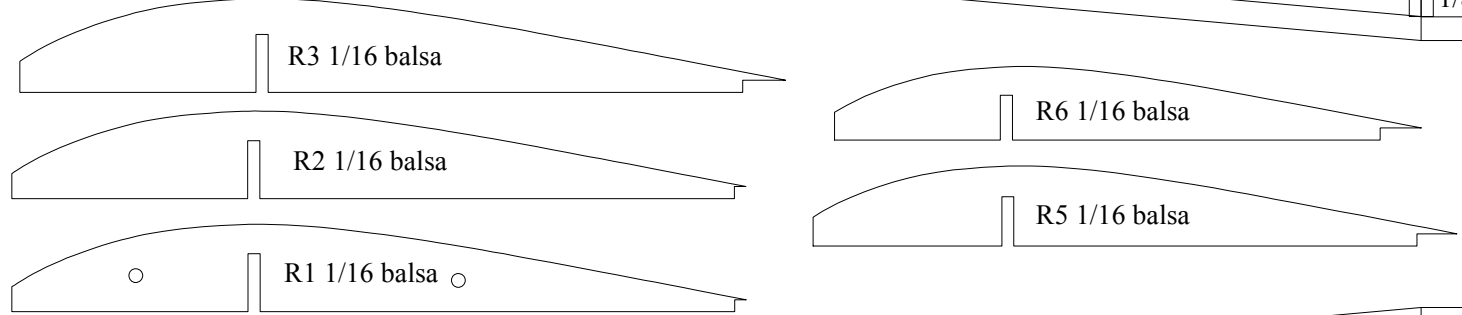
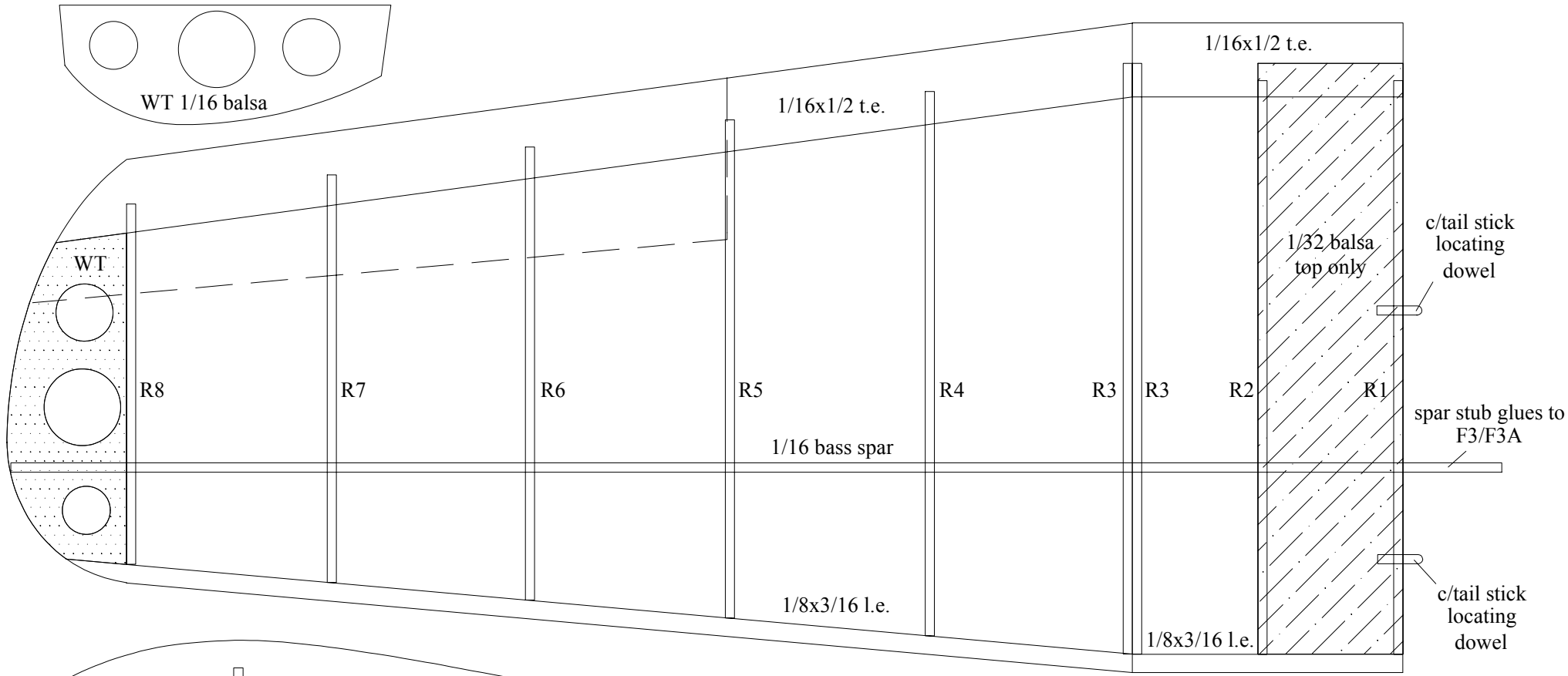

WING CONSTRUCTION

pin centre part of spar flat to board
 pin down l.e. & t.e. parts
 glue in place R1, R2 and the innermost R3
 all ribs are at 90 degrees to the board
 fit 1/32 balsa c/s sheet
 allow to dry

unpin centre part and lower spar over remaining wing plan
 pin down l.e. & t.e. parts
 glue in place remaining ribs and WT

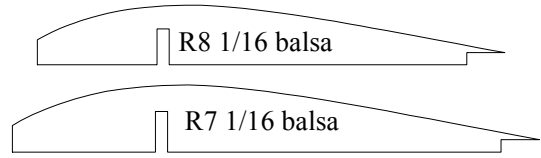

Peter Rake's
Martin MO-1
 Copyright P. Rake 2015

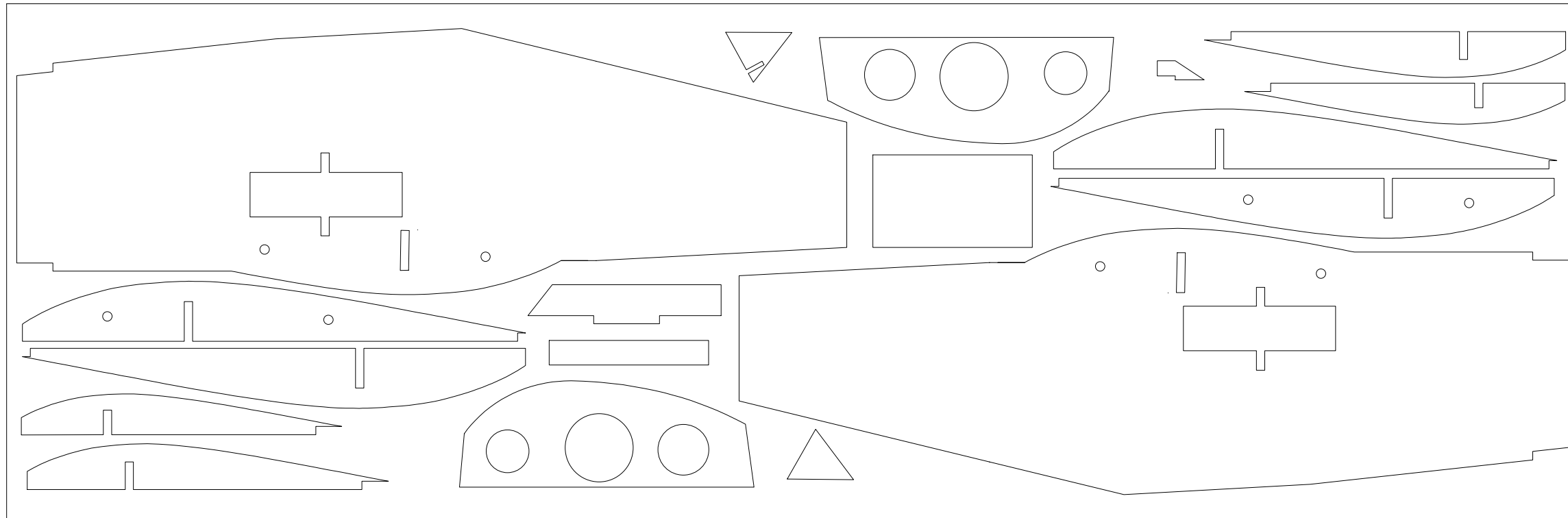

1/16 balsa

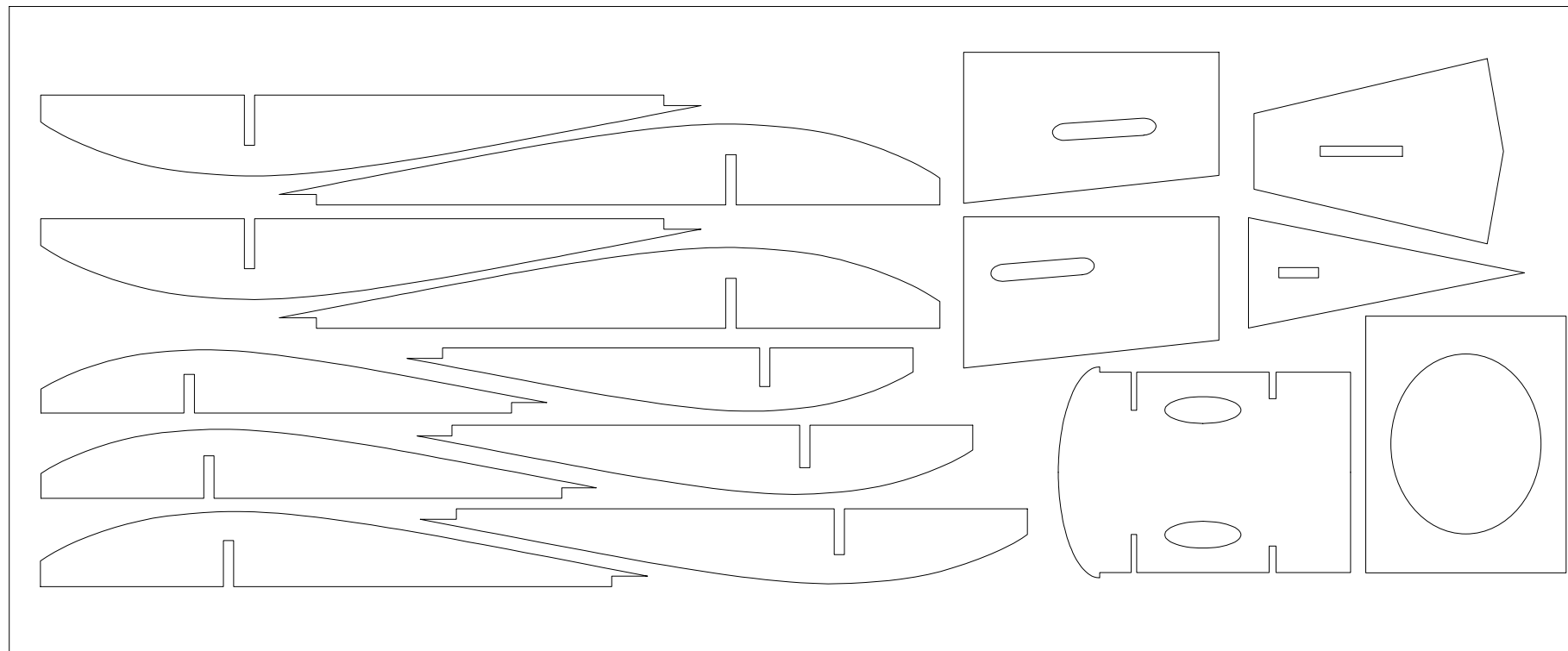

1/16 balsa

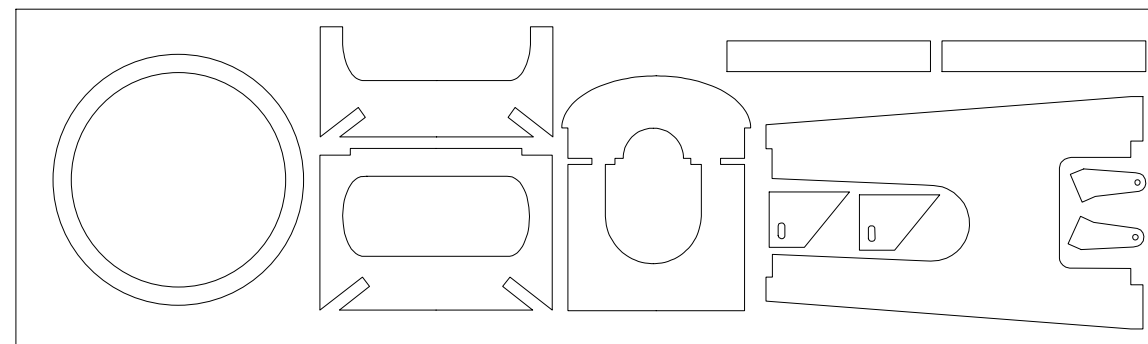

1/32 ply

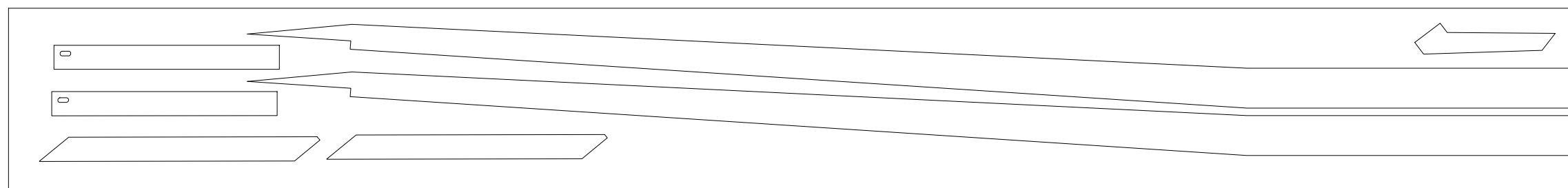

1/16 bass