

NOTE
TOP OF FUSELAGE UNDER WING IS LEFT UNCOVERED FOR ACCESS TO IGNITION SYSTEM.

NOTE
COAT SIDES & FIREWALL WITH PLENTY OF CEMENT TO PROTECT THEM FROM OIL.

NOTE: USE 1/4" DIA. 6" PITCH PROPELLER

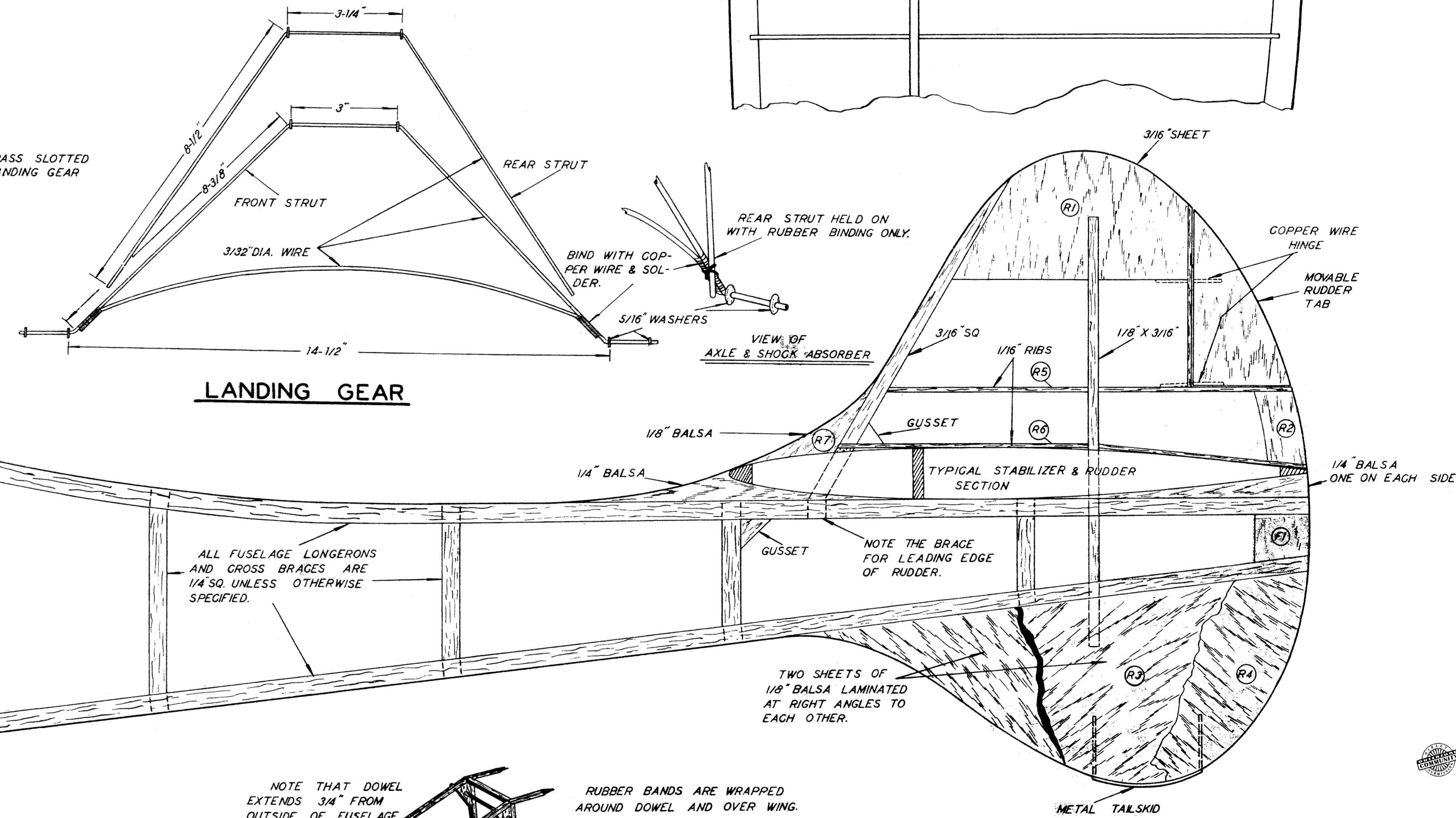
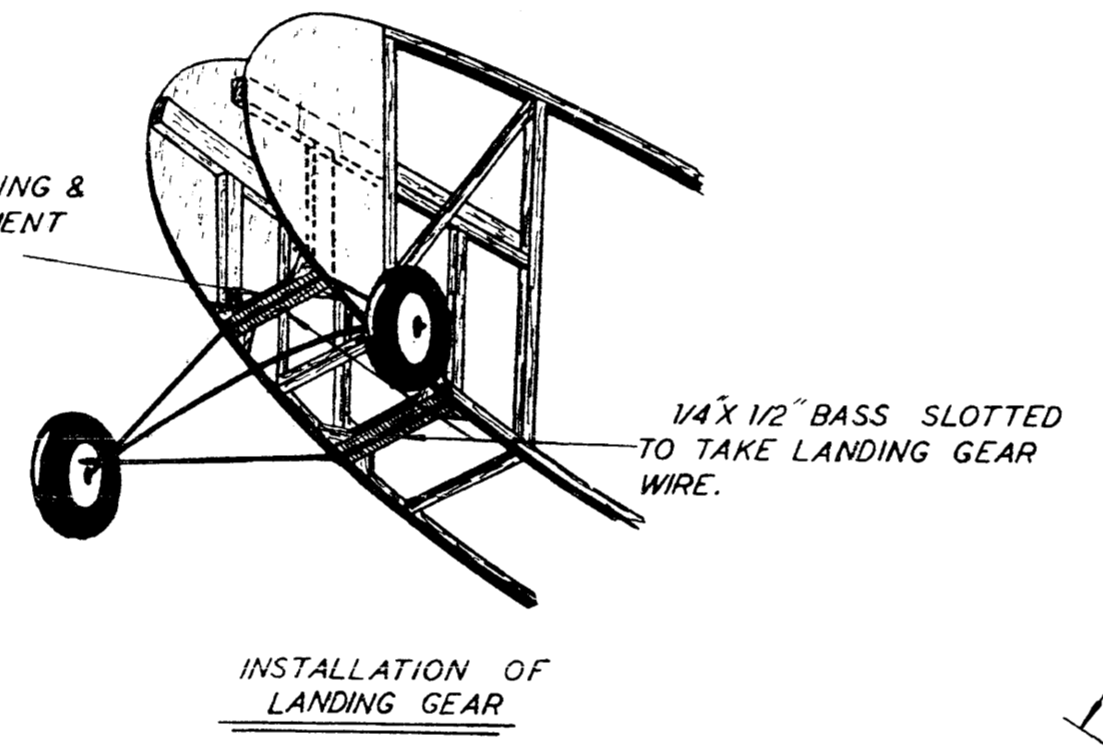
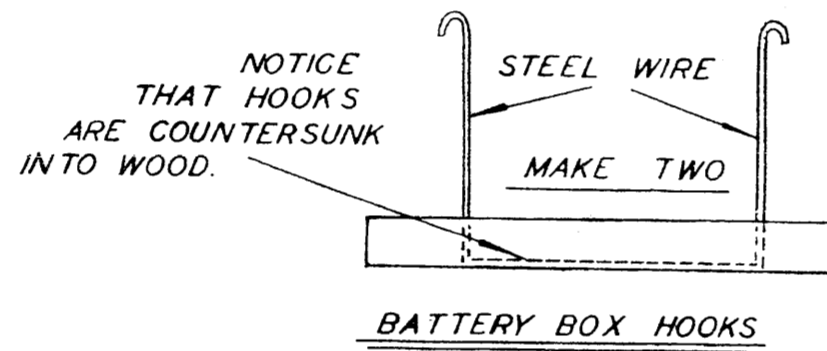

LANDING GEAR

LANDING GEAR

NOTE
FUSELAGE IS ENTIRELY COVERED WITH 1/32" SHEET FORWARD OF "A-A". THE FUSELAGE HAS A DOUBLE LAYER (LAMINATED). THE REAR PORTION OF FUSELAGE HAS A SINGLE PLY COVERING.

NOTE: GUSSETS ARE ALL AT RIGHT ANGLES.

NOTE THAT DOWEL EXTENDS 3/4" FROM OUTSIDE OF FUSELAGE

RUBBER BANDS ARE WRAPPED AROUND DOWEL AND OVER WING.

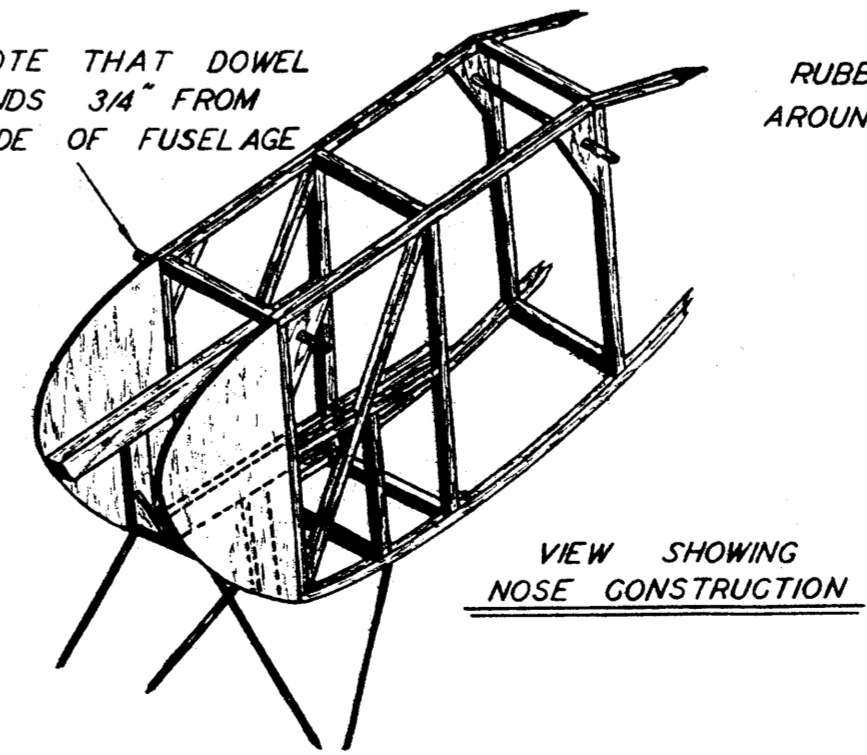
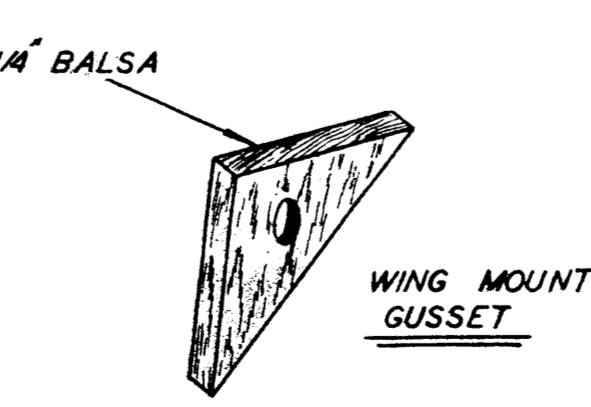
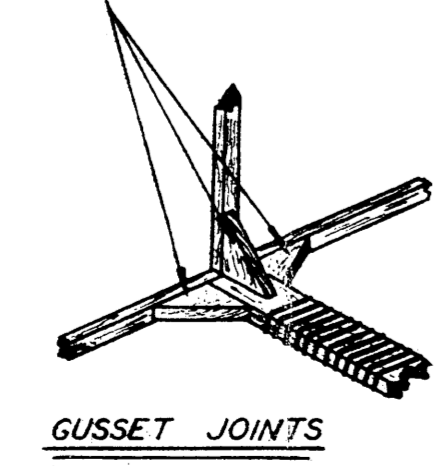

APPROVED BY Walter Good

Walter Good's CHAMPION

GUFF

MEETS PRESENT NAA REQUIREMENTS

SPAN 6 FT.	LENGTH 36"	CLASS-C-GAS
------------	------------	-------------

DRAWN BY Leo Vastanion & Armando Simbello

MIDWEST MODEL SUPPLY 445 W. 69TH ST. CHICAGO, ILL.

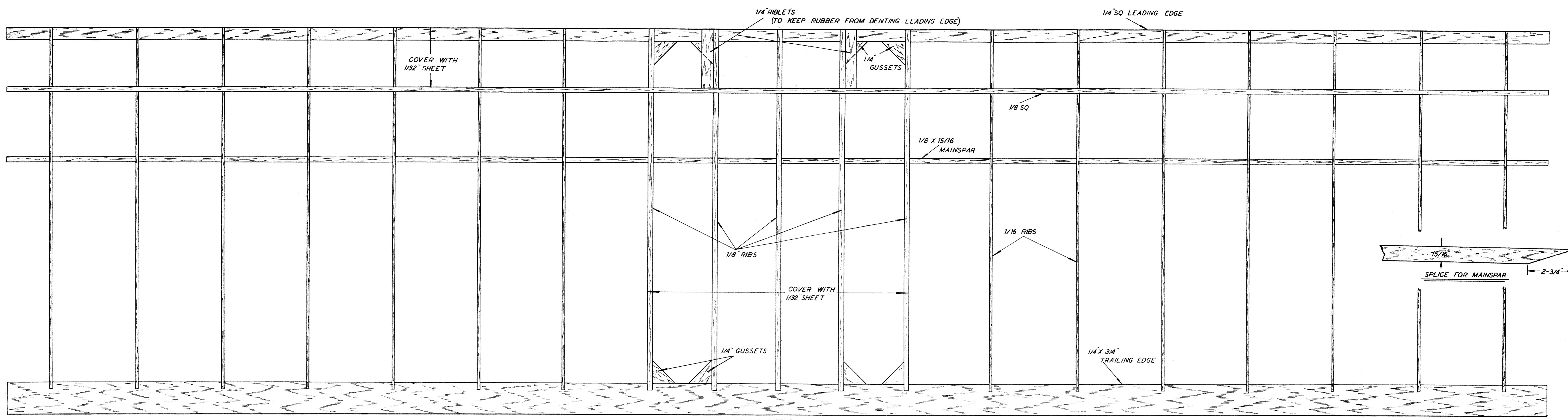

MIDSECTION OF WING

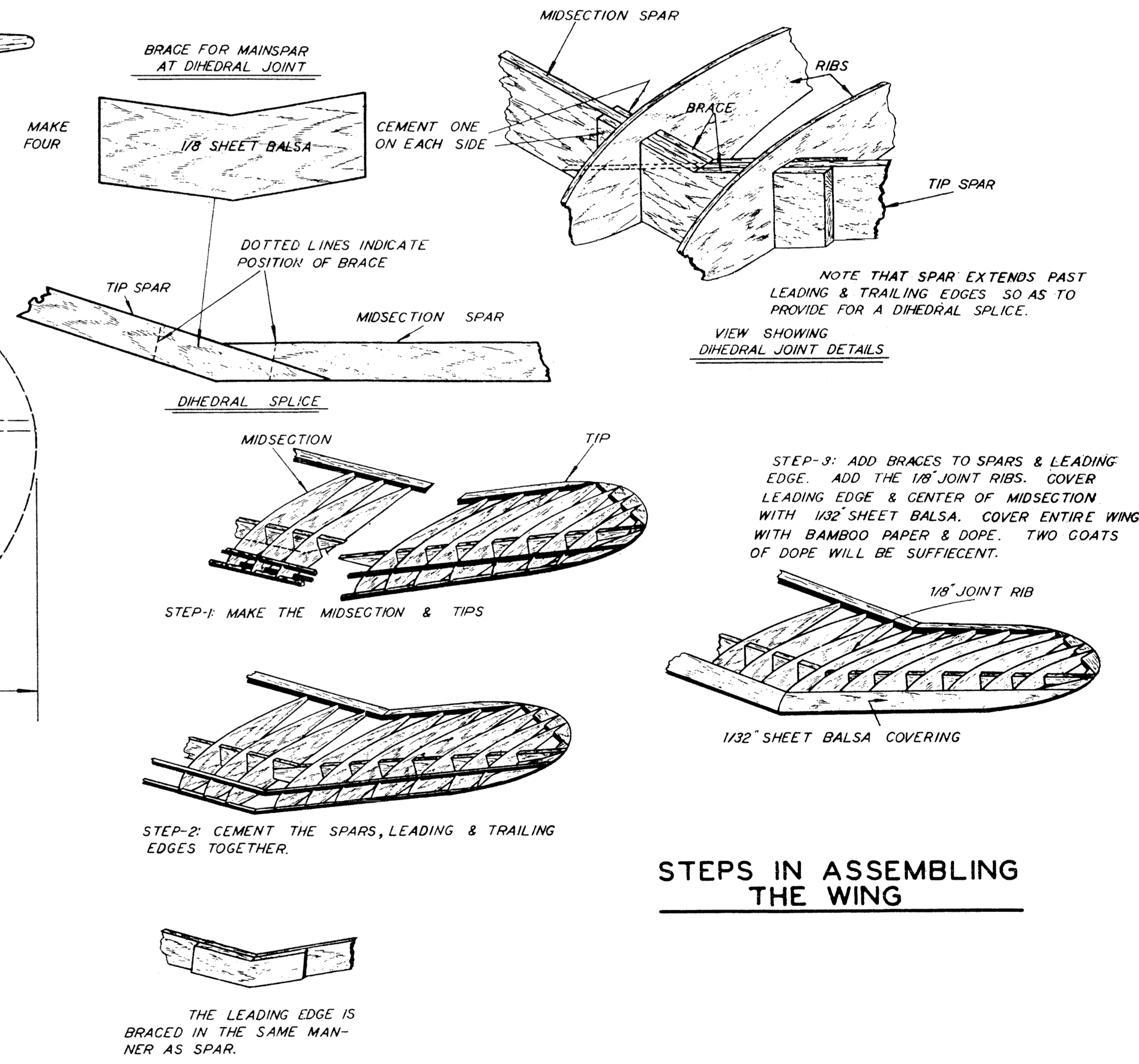
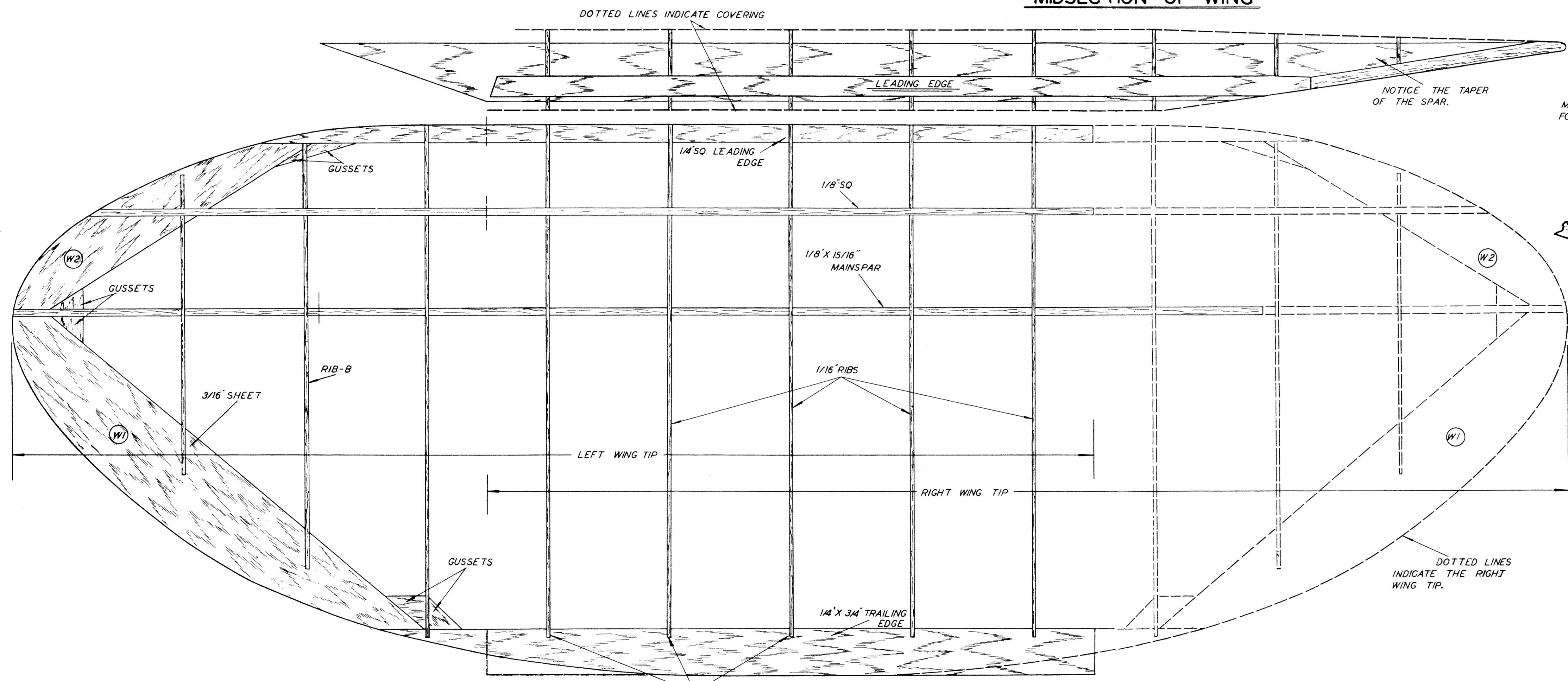

STEPS IN ASSEMBLING THE WING

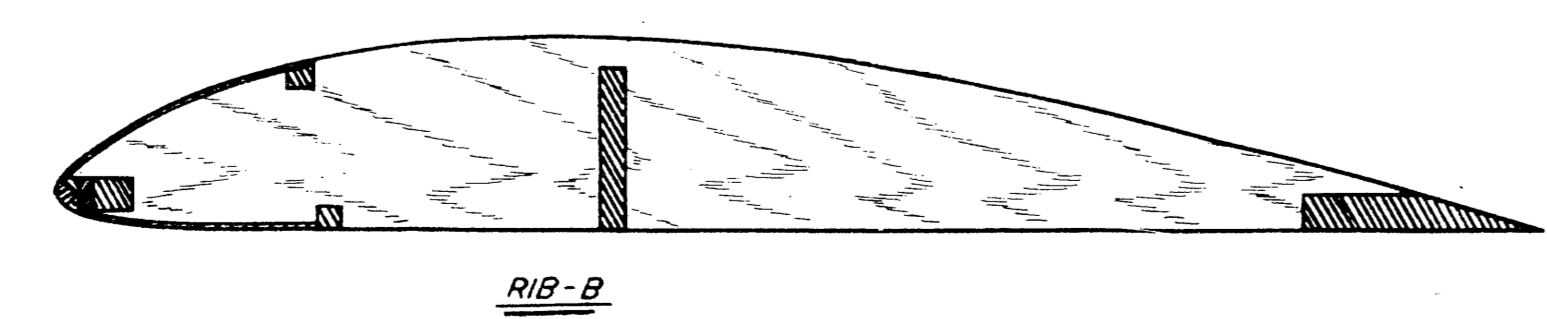
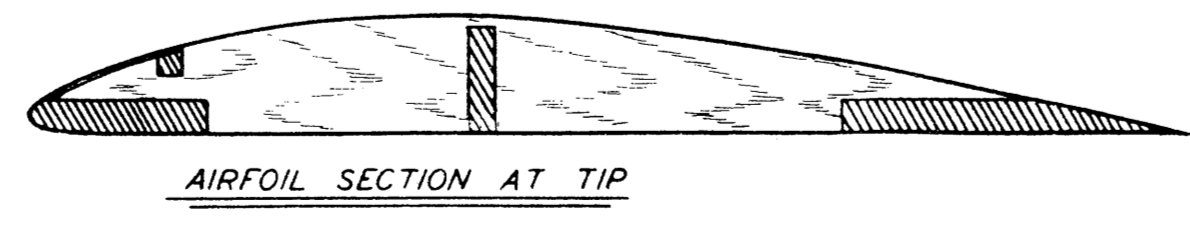
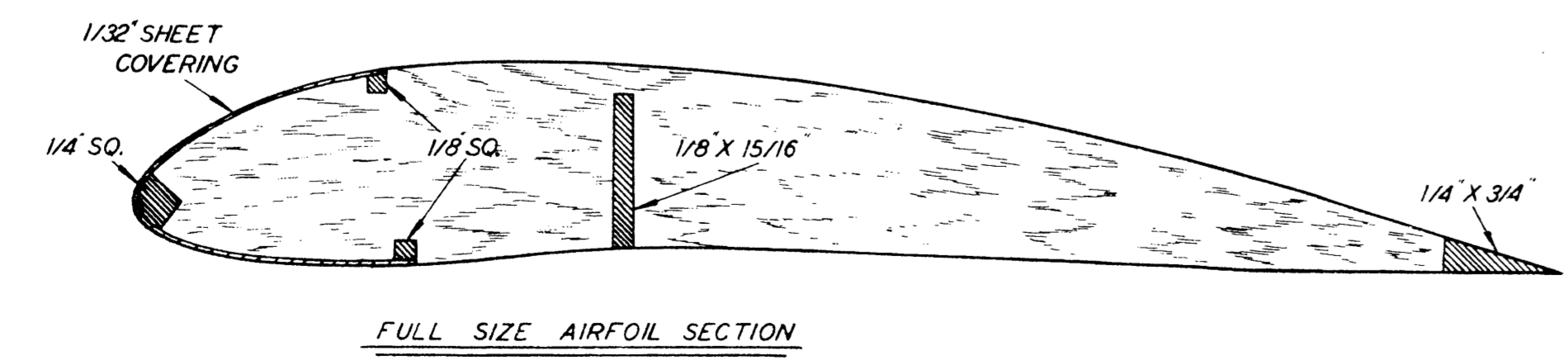
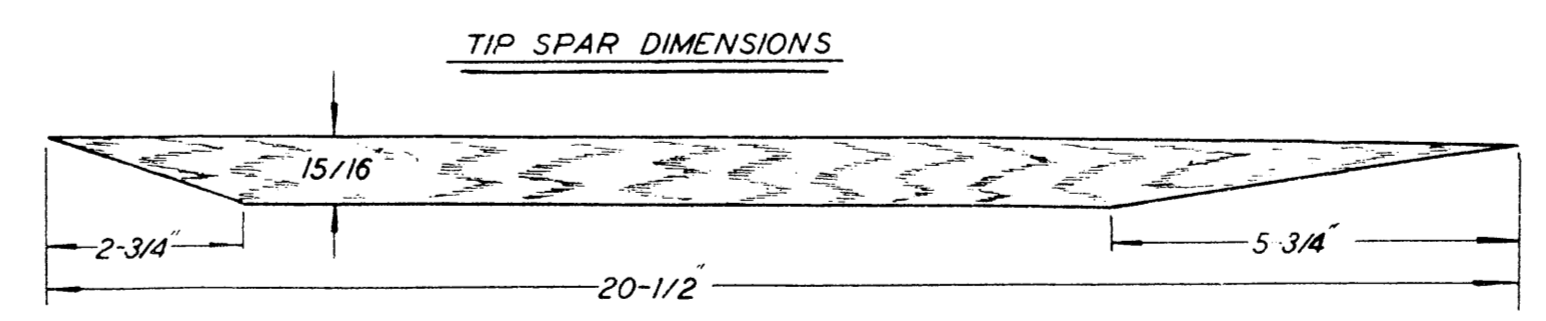

Walter Woods' CHAMPION

GUFF

MEETS PRESENT NAA REQUIREMENTS

SPAN 6 FT.	LENGTH 36"	CLASS-C-GAS
------------	------------	-------------

DRAWN BY
Leo Venturini + Armando Simbello

MIDWEST MODEL SUPPLY 445 W. 69TH ST CHICAGO, ILL.

