

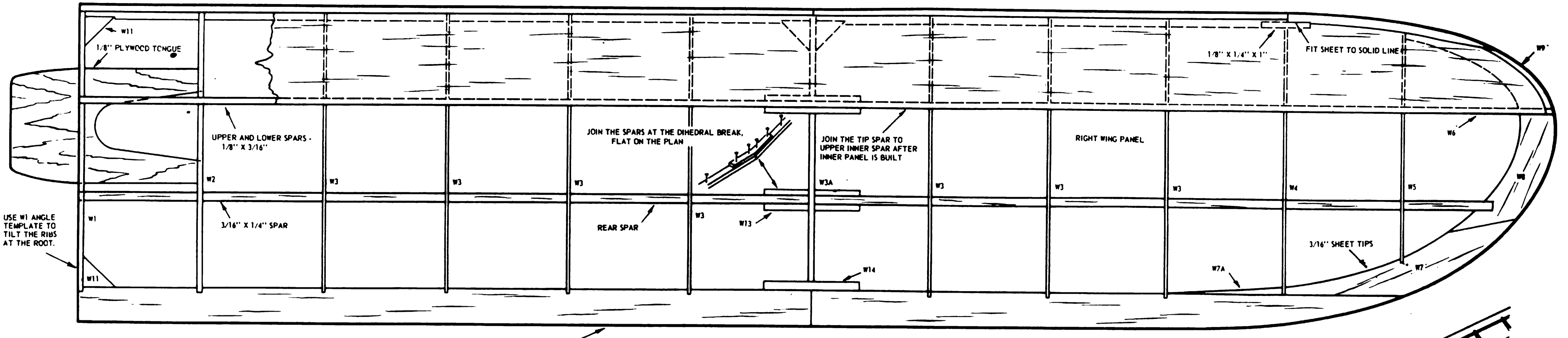

MODIFY CABIN AREA AS NECESSARY FOR ONE-PIECE WING IF DESIRED

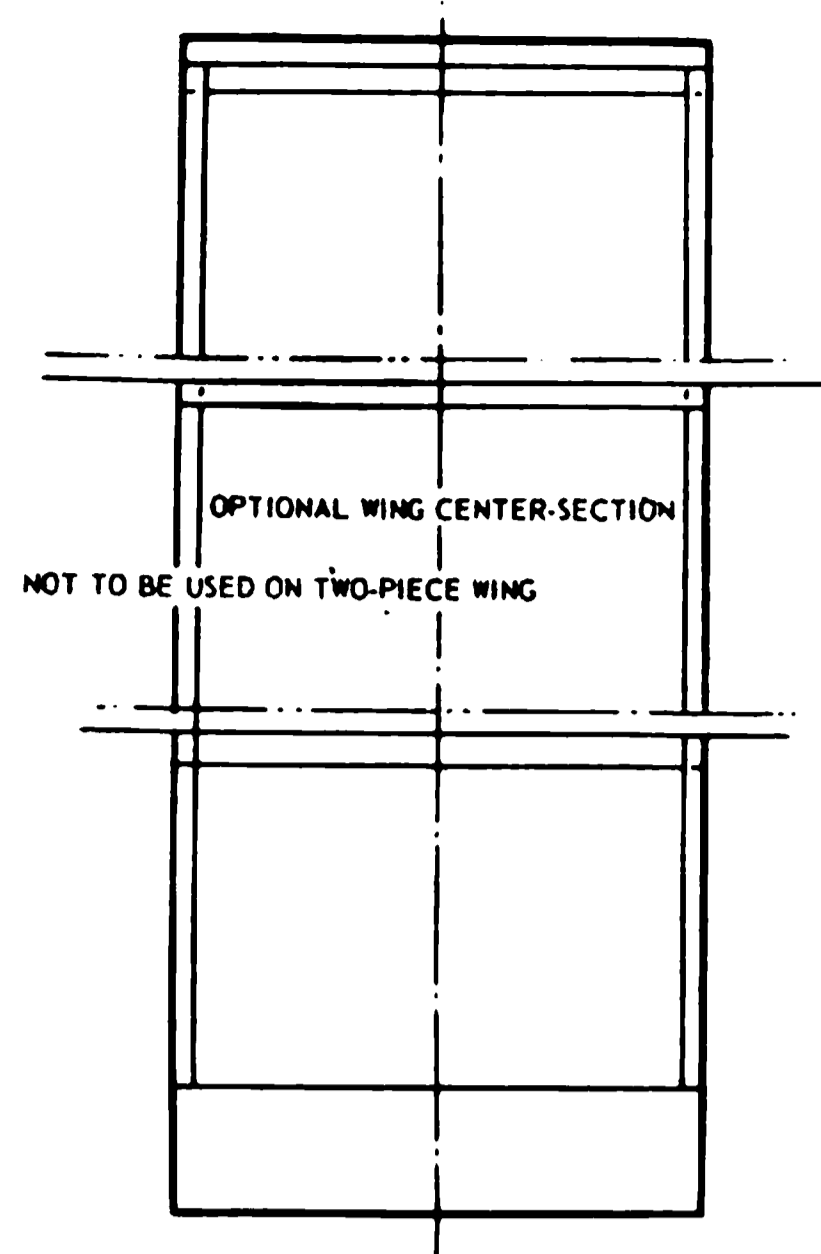

WHEN ASSEMBLING THE WING PANELS, PACK UP PARTS AS INDICATED WITH THIS MARK

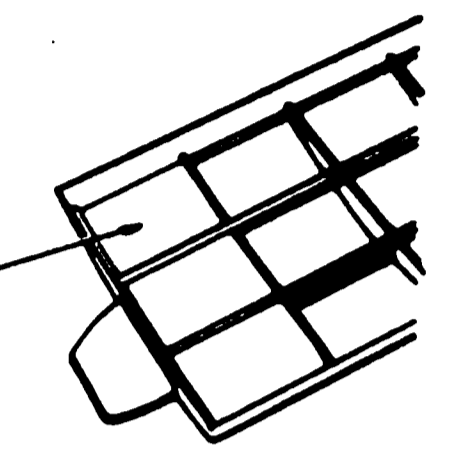
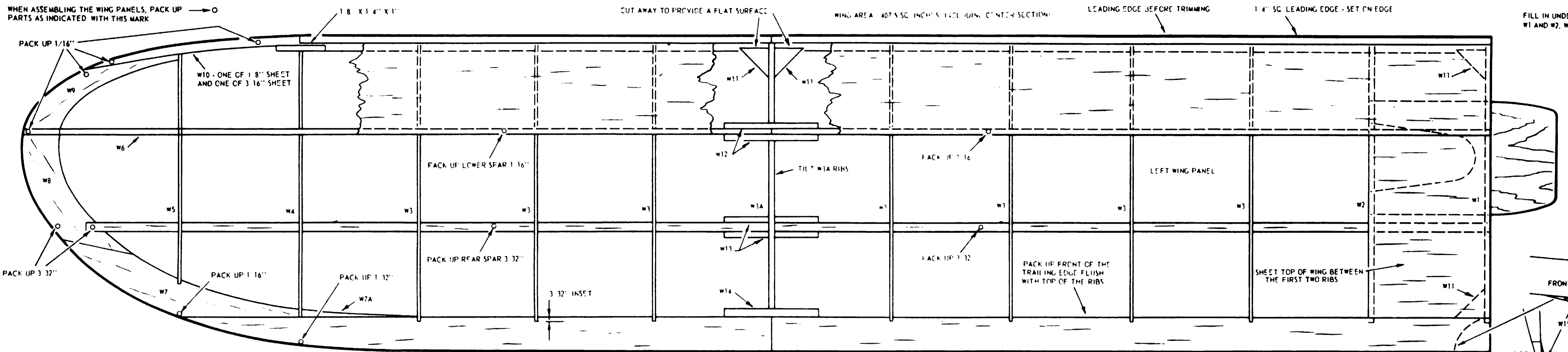

FILL IN UNDERSIDE OF WING BETWEEN W1 AND W2, WITH 1/16" SHEET BALSAs.

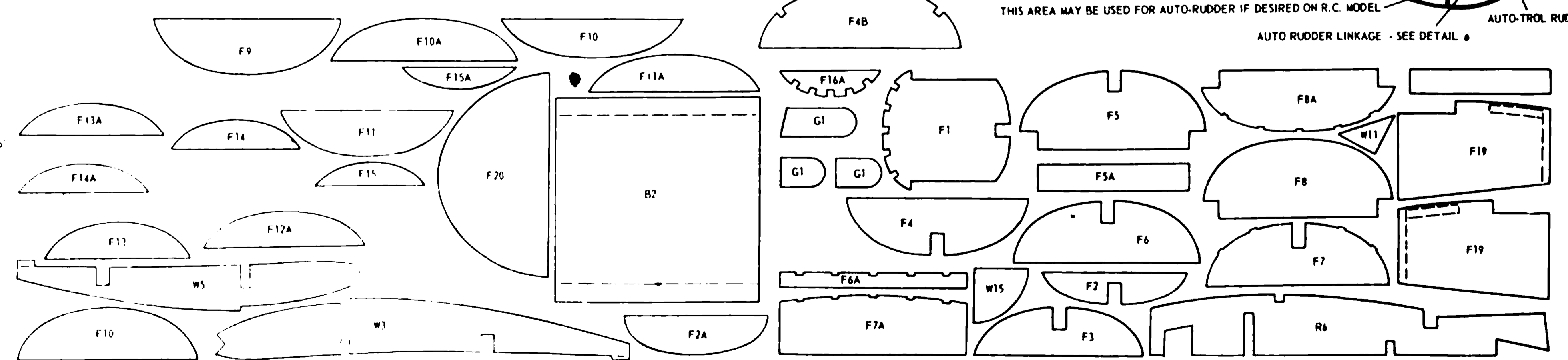
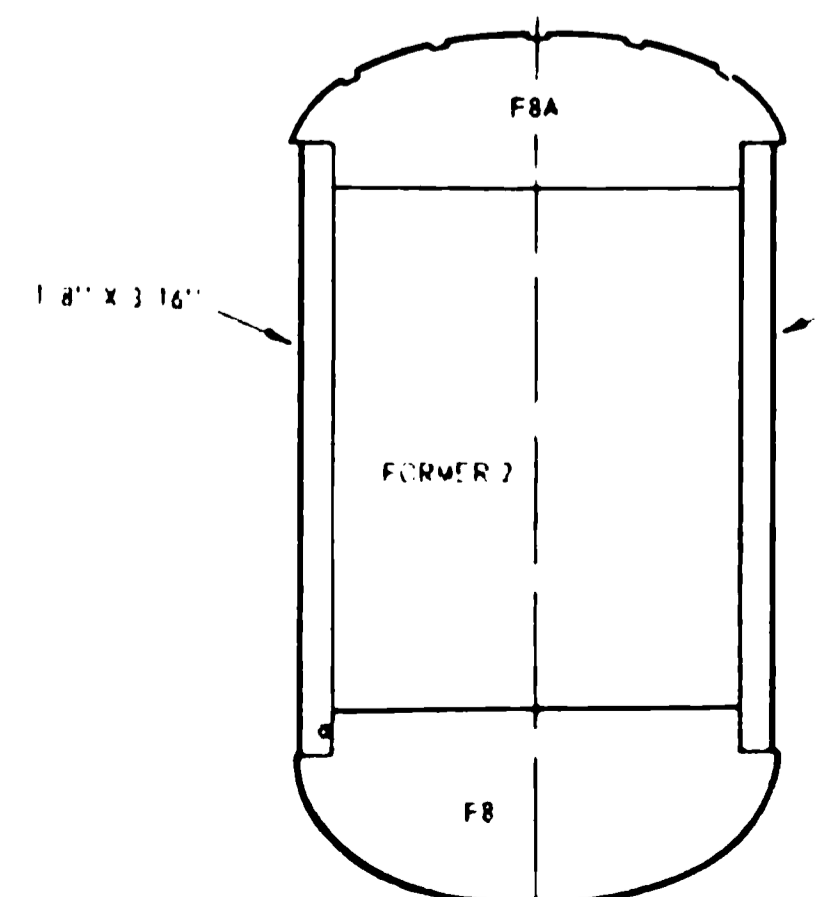
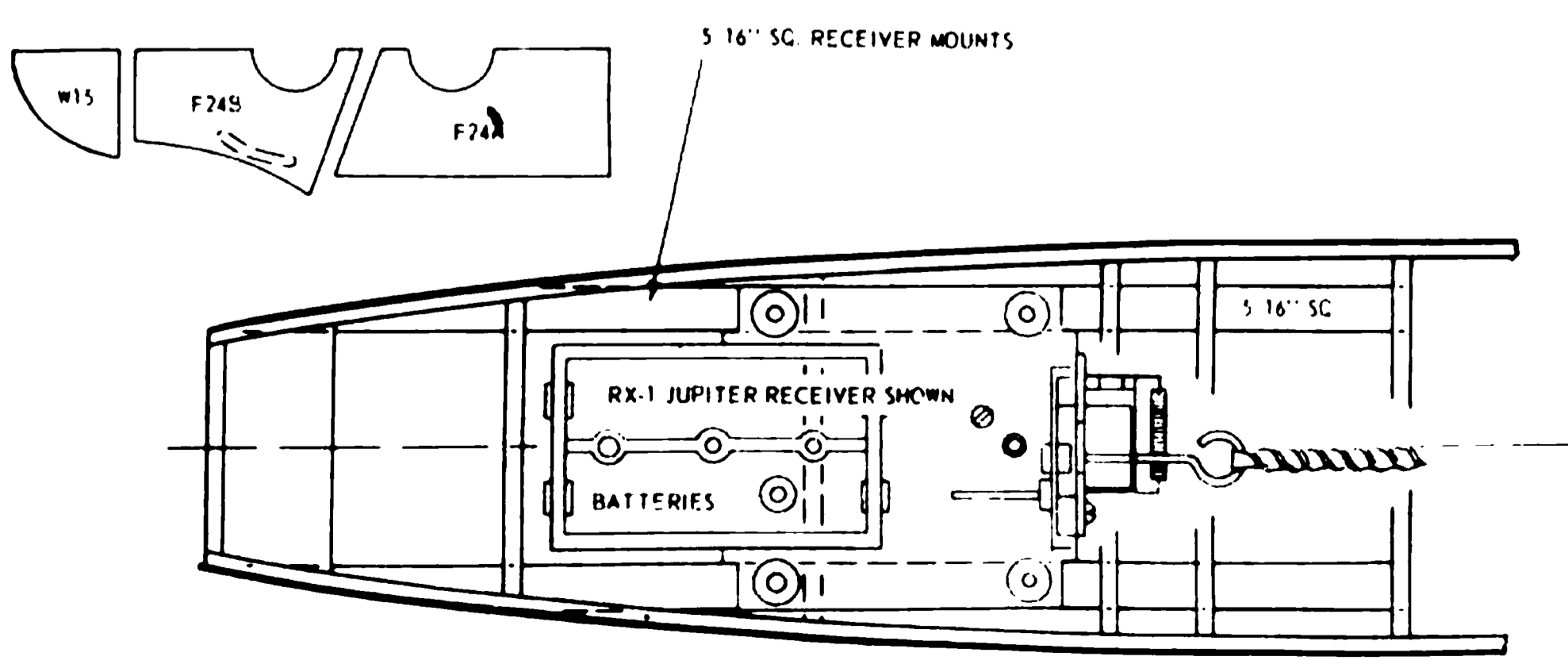
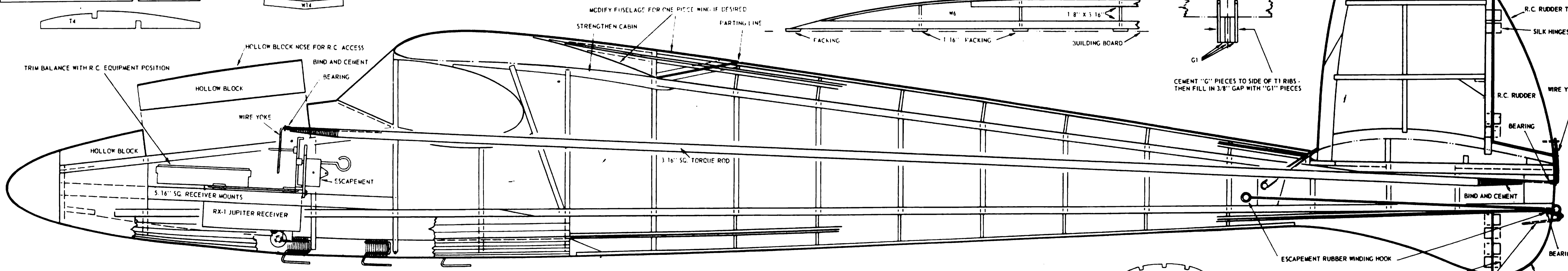
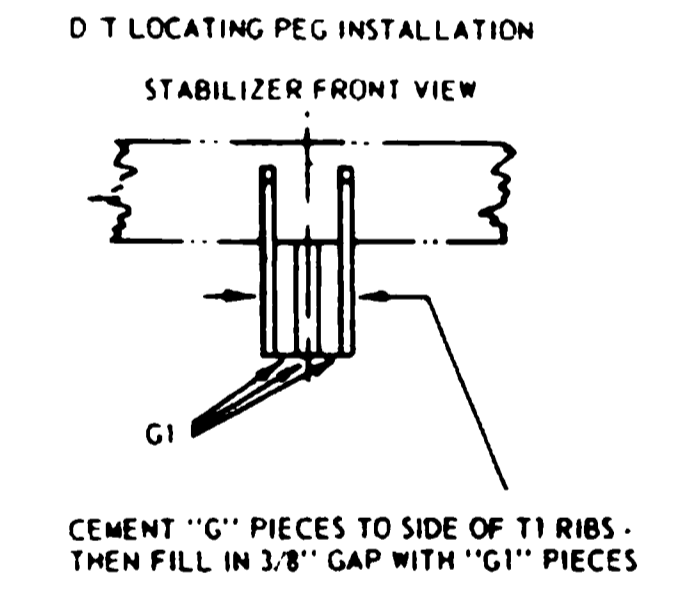
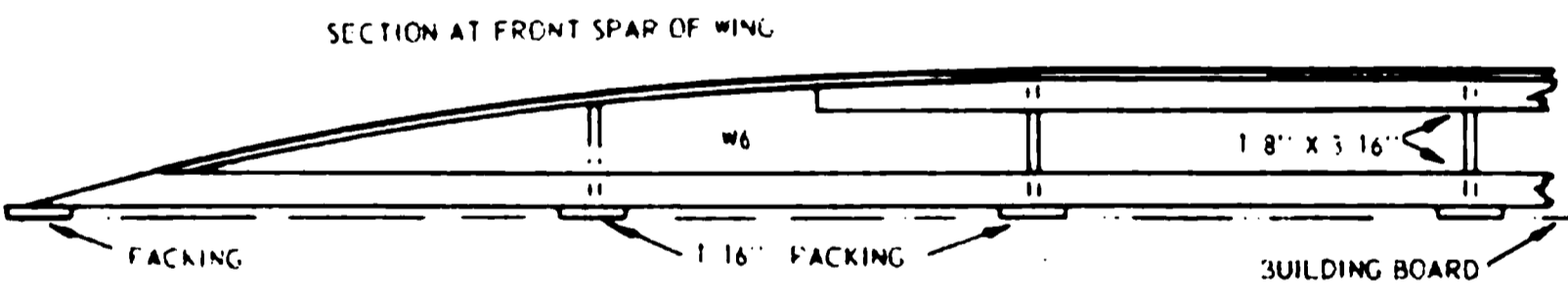
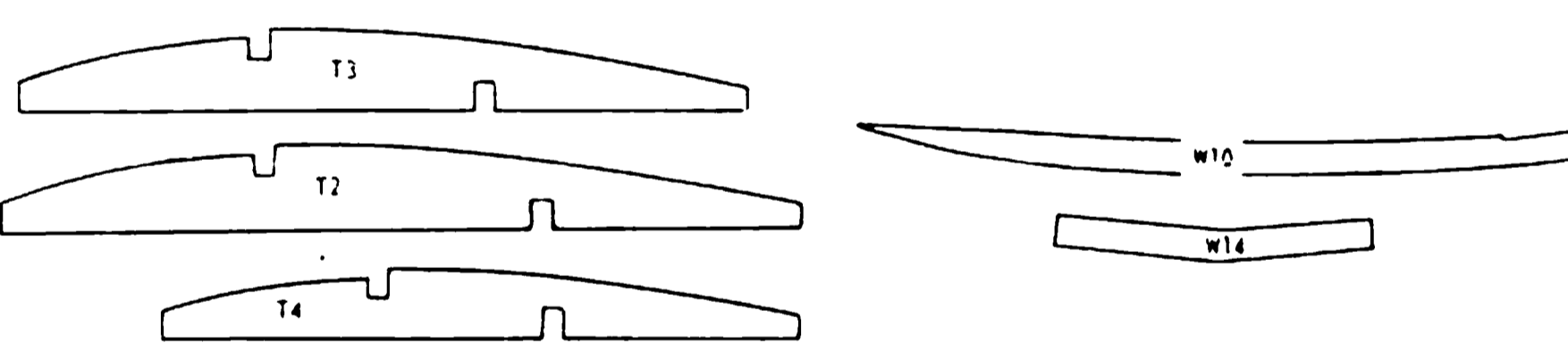
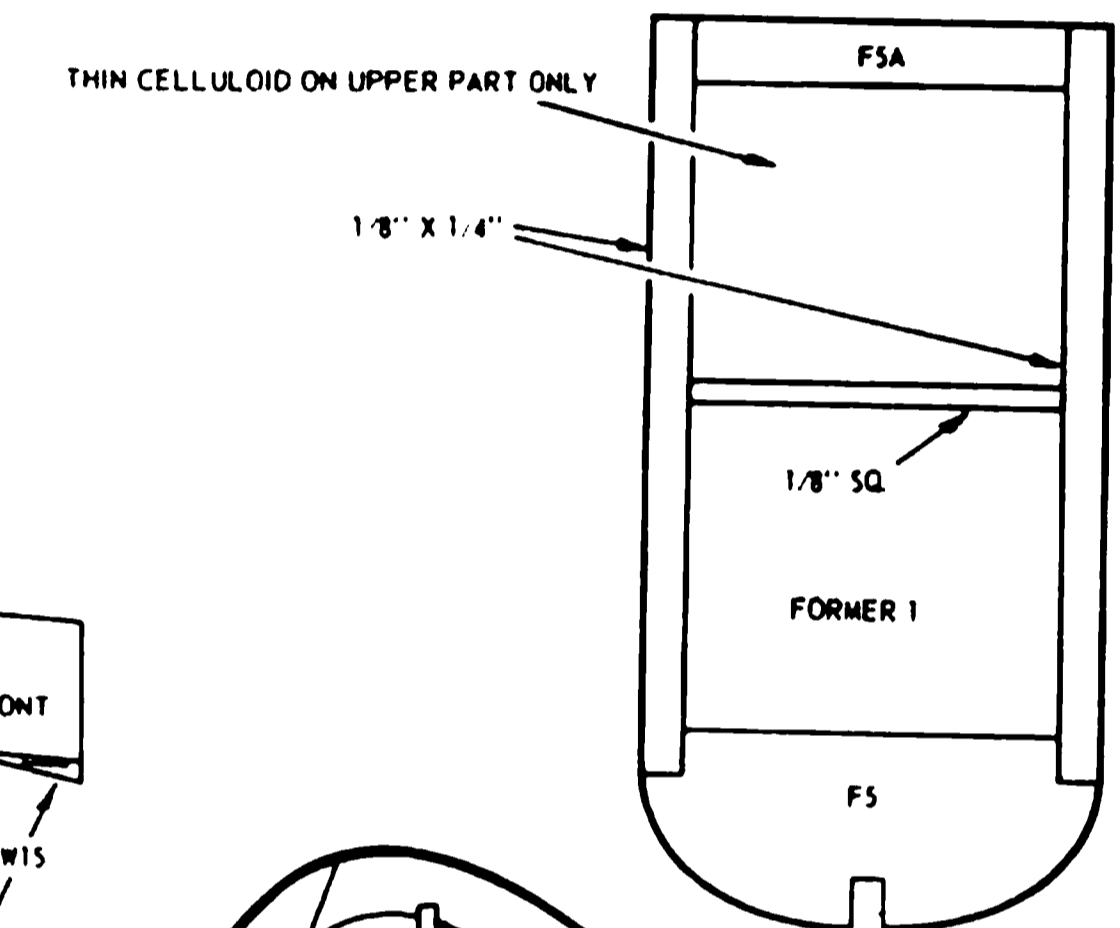

THIS AREA MAY BE USED FOR AUTO-RUDDER IF DESIRED ON R.C. MODEL. AUTO RUDDER LINKAGE - SEE DETAIL