

CRINOLINE HINGES

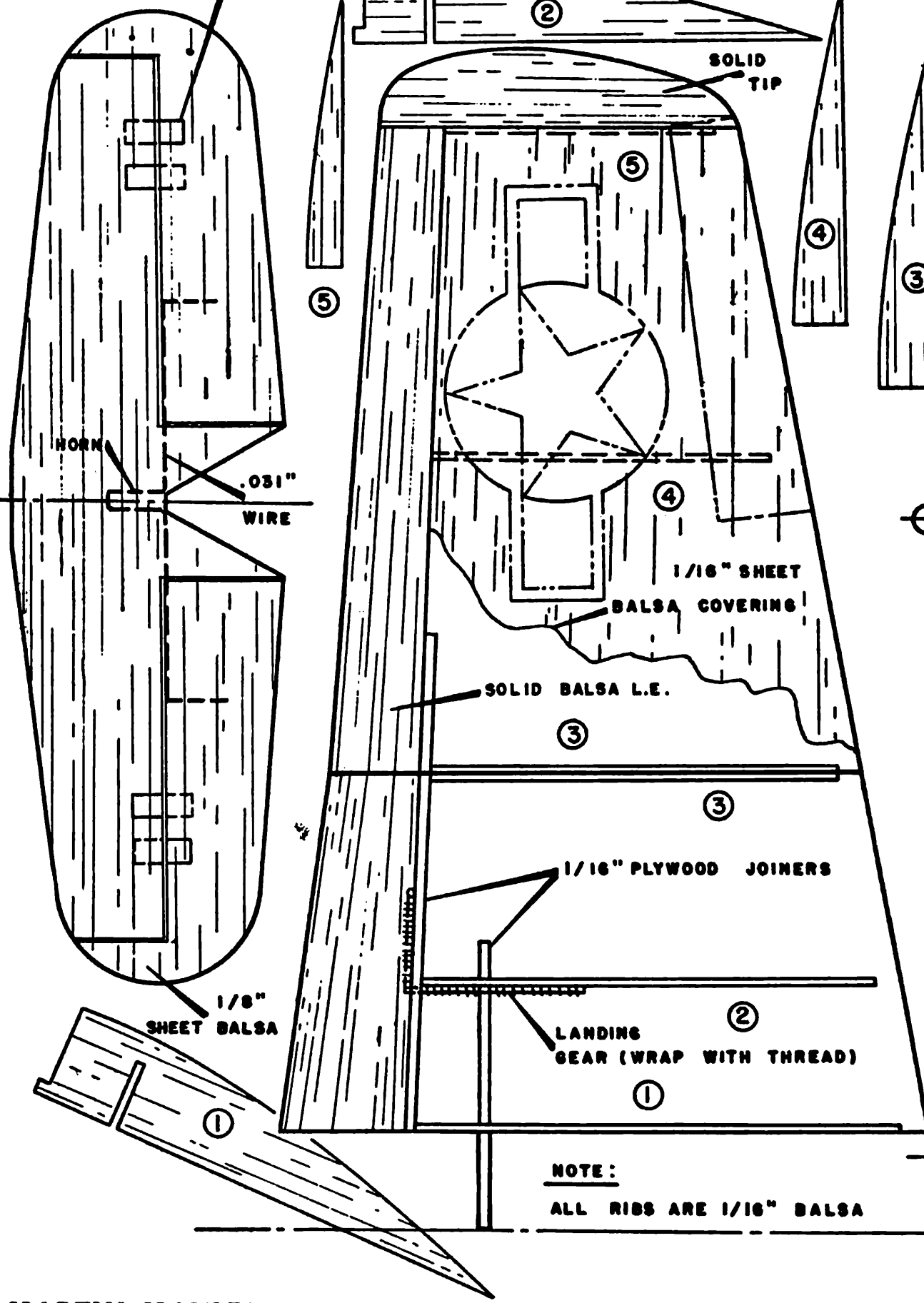

NOTE:
ALL RIBS ARE 1/16" Balsa

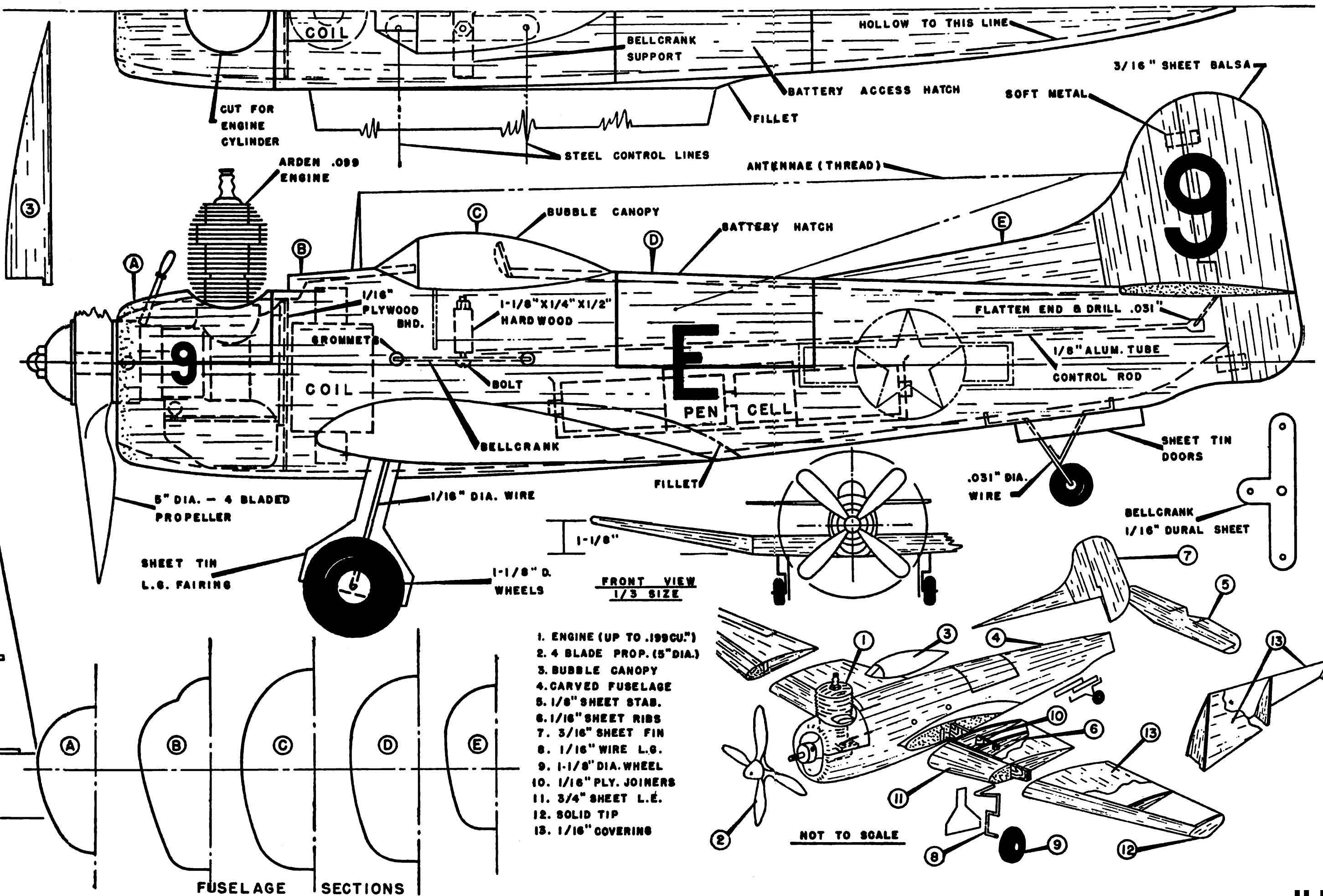

1. ENGINE (UP TO .199CU")
2. 4 BLADE PROP. (5" DIA.)
3. BUBBLE CANOPY
4. CARVED FUSELAGE
5. 1/8" SHEET STAB.
6. 1/16" SHEET RIBS
7. 3/16" SHEET FIN
8. 1/16" WIRE L.G.
9. 1-1/8" DIA. WHEEL
10. 1/16" PLY. JOINERS
11. 3/4" SHEET L.E.
12. SOLID TIP
13. 1/16" COVERING

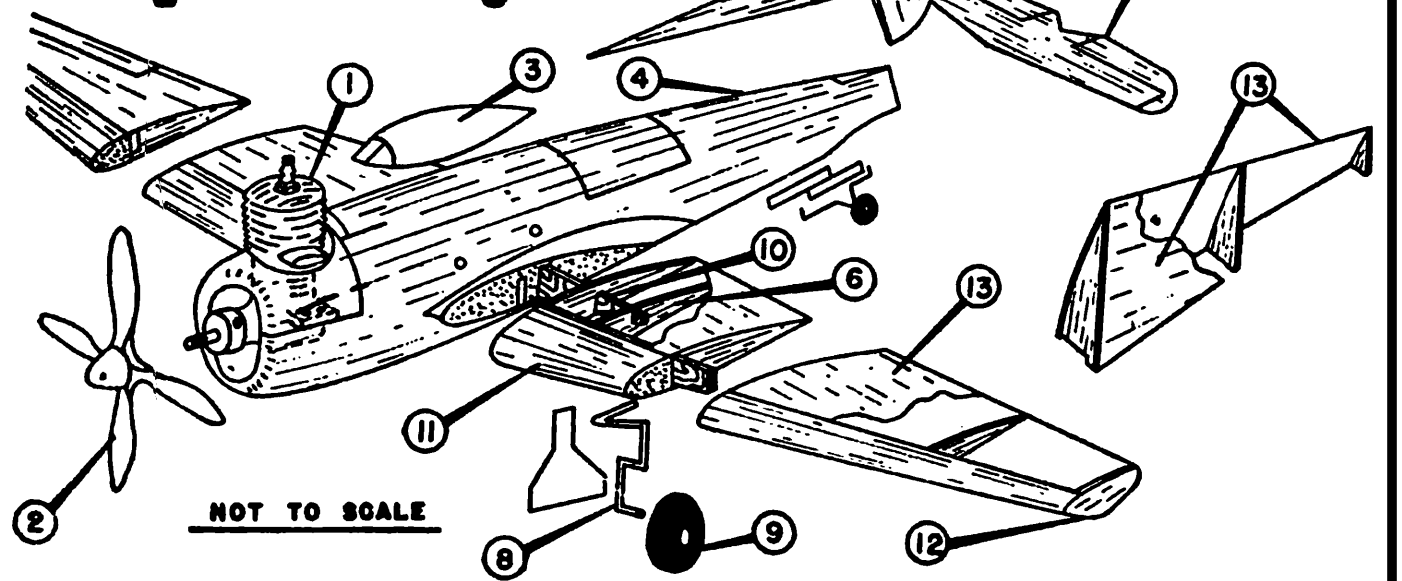

MARTIN MAULER—An Air Trails Exclusive Full Size Plan Feature