

WING PLAN

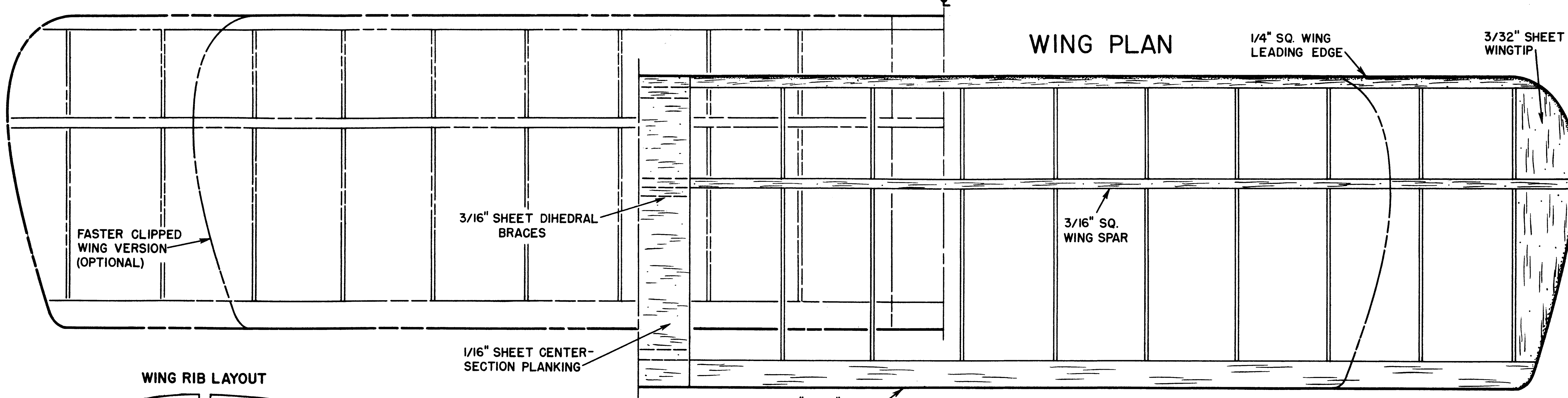

WING RIB LAYOUT



WING DIHEDRAL LAYOUT

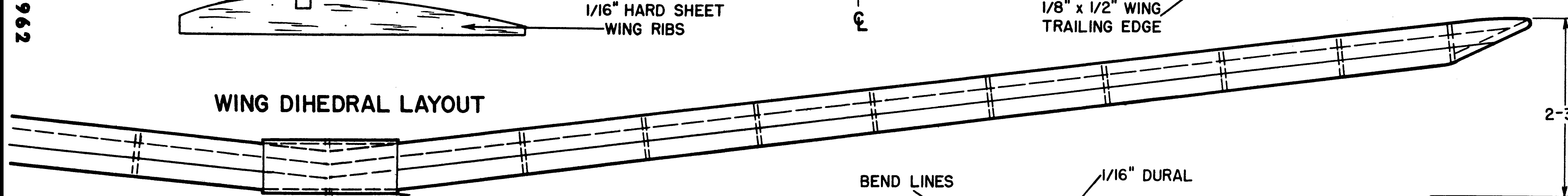

FUSELAGE TOP VIEW

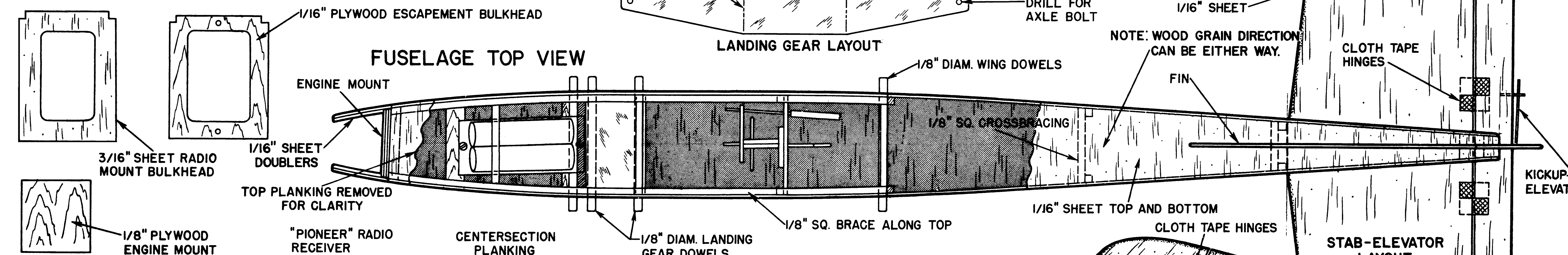

LANDING GEAR LAYOUT

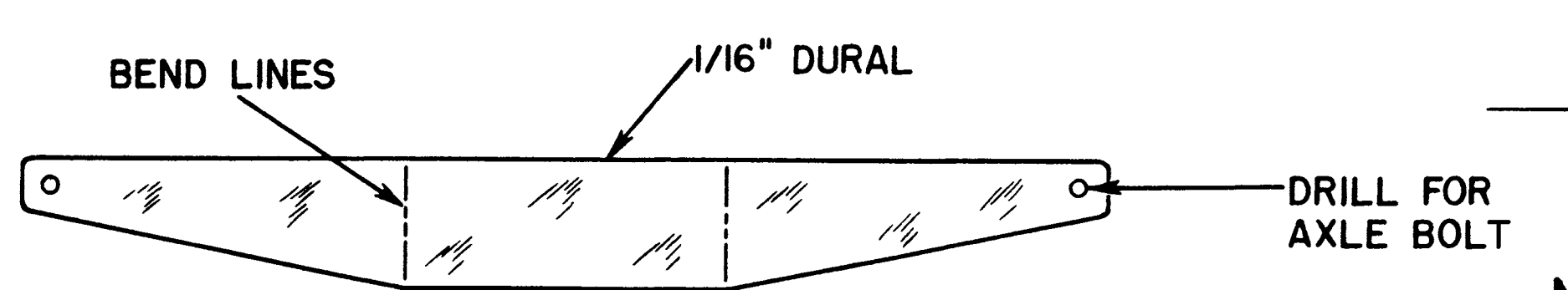

STAB-ELEVATOR LAYOUT

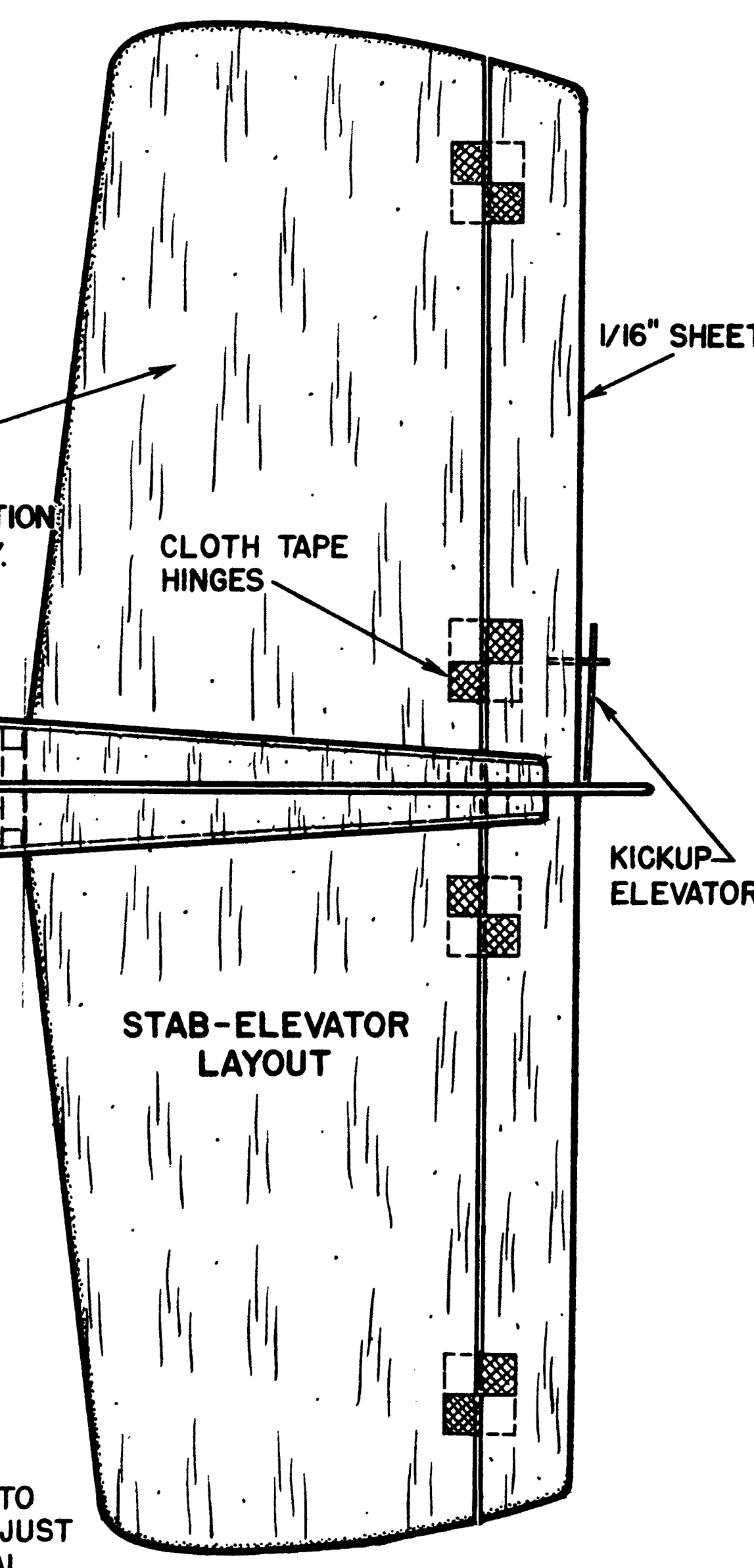

FUSELAGE SIDE VIEW

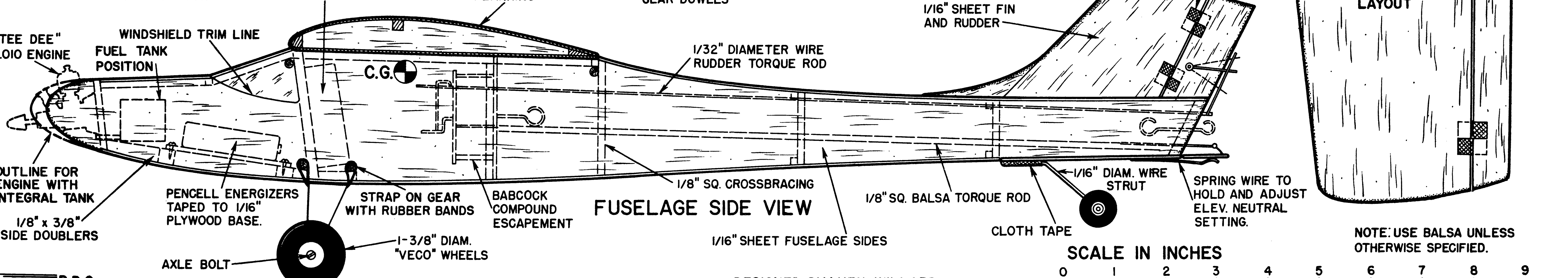

SCALE IN INCHES



DESIGNED BY: KEN WILLARD

FULL SCALE PLANS AVAILABLE. SEE PAGE 60