

A 34 1/2" WINGSPAN, RUBBER POWERED SCALE MODEL SCALE 3/4" = 1"

DOUGLAS O46A

Designed by
J. D. McHARD

Copyright of

The Aeromodeller Plans Service
38 CLARENDON RD. WATFORD HERTS

ALL WOODS UNLESS OTHERWISE STATED ARE Balsa

STAGES IN FORMING UNDERCARRIAGE

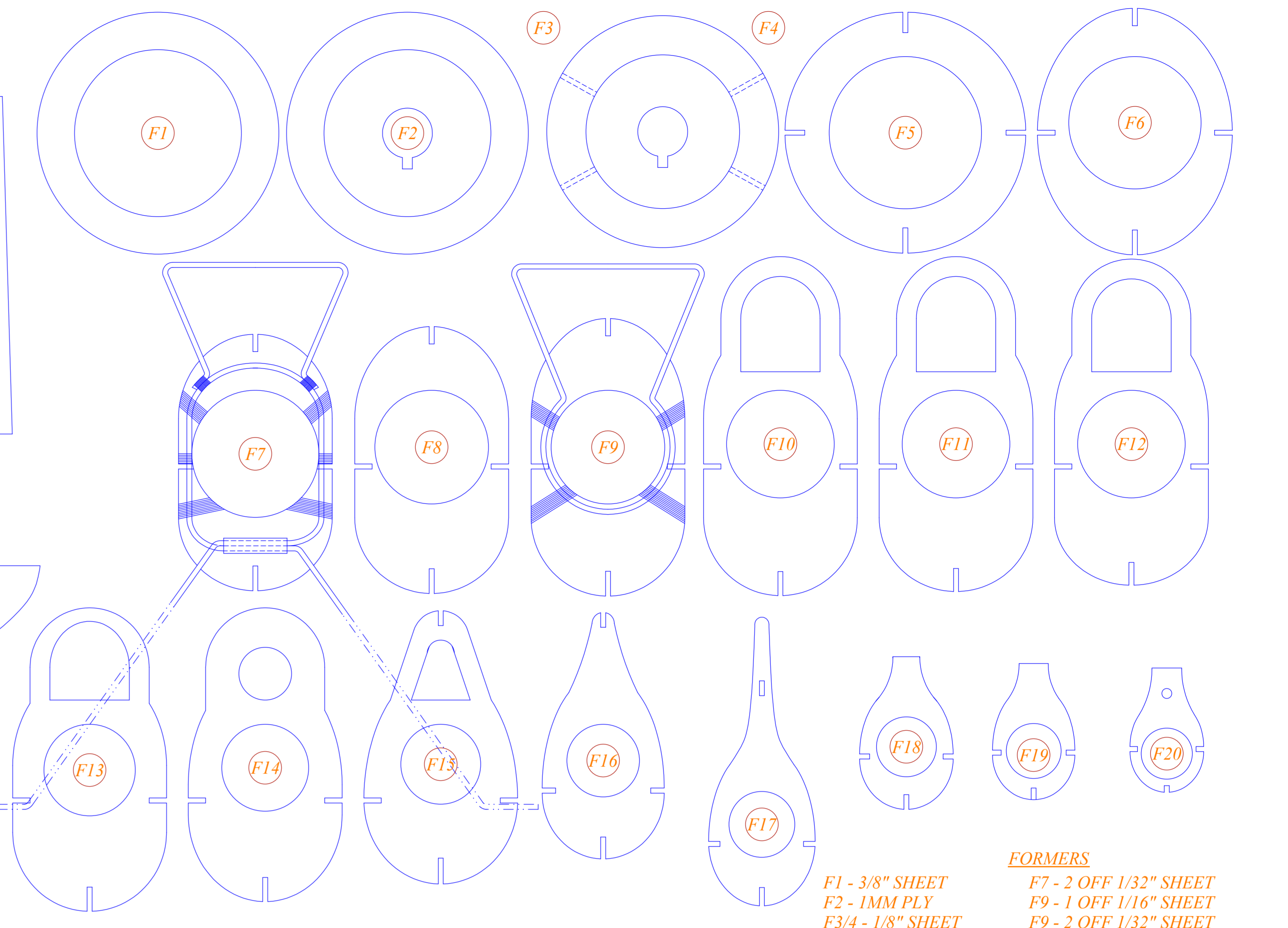
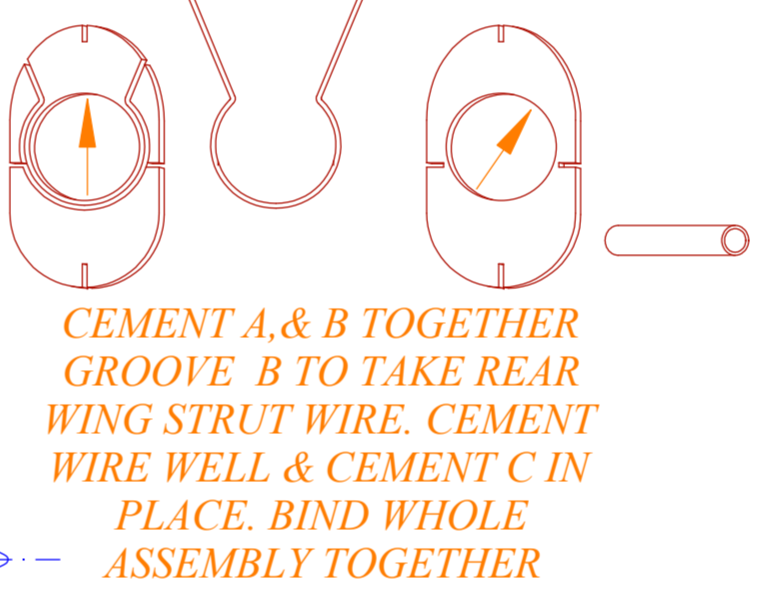
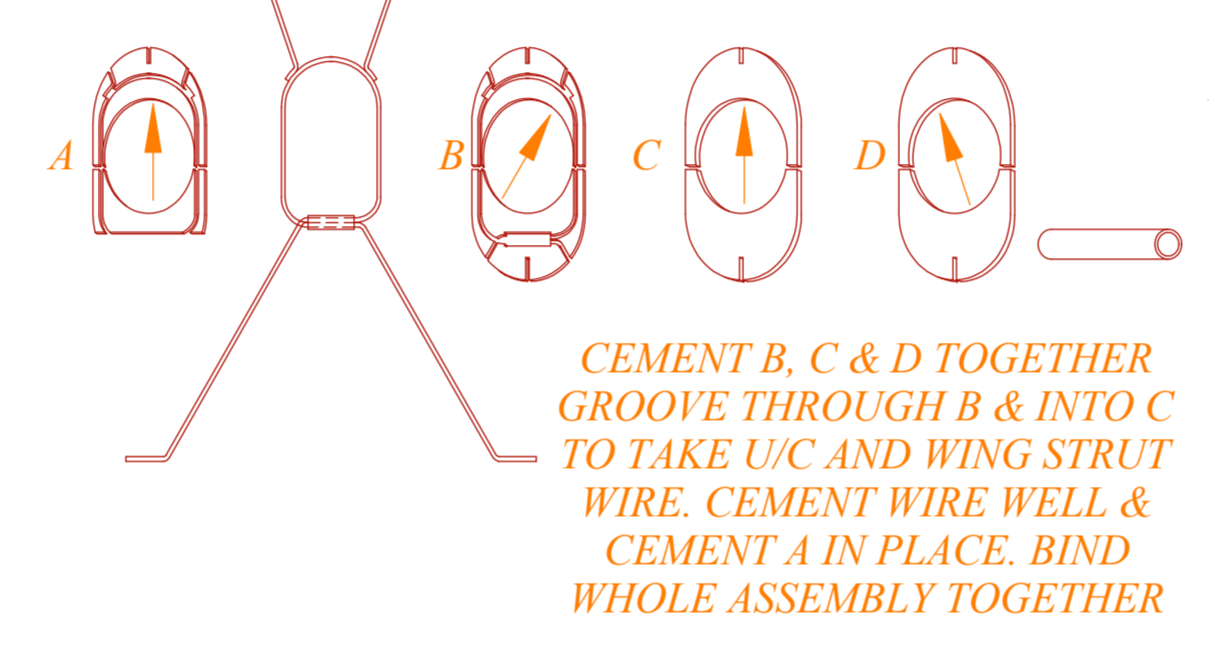
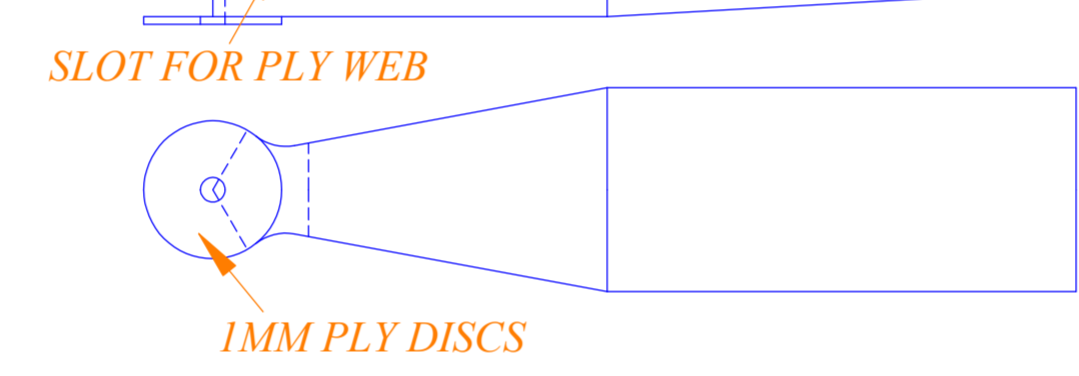
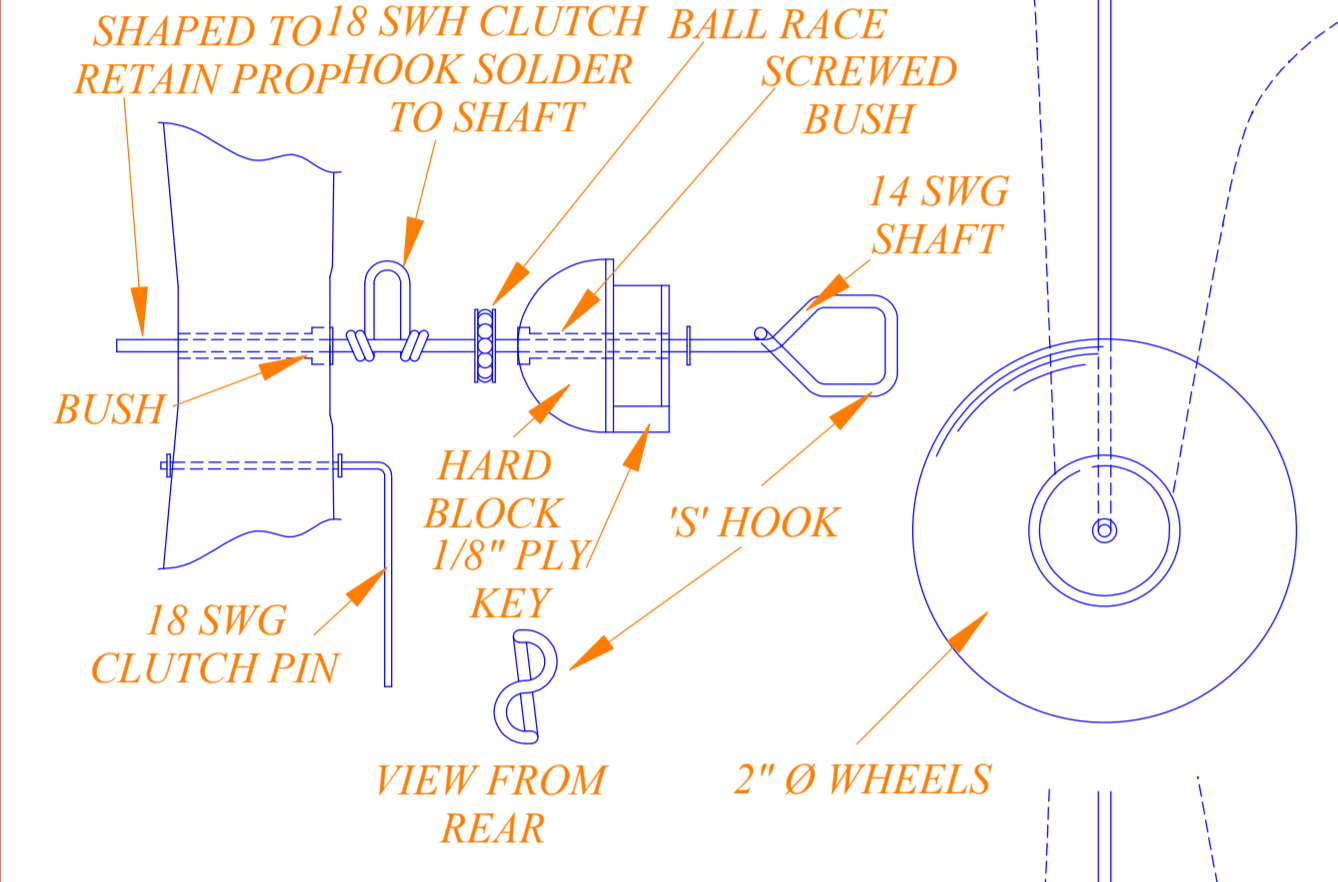
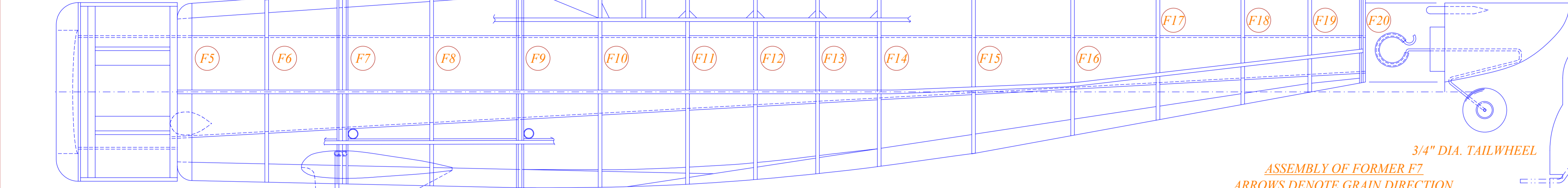
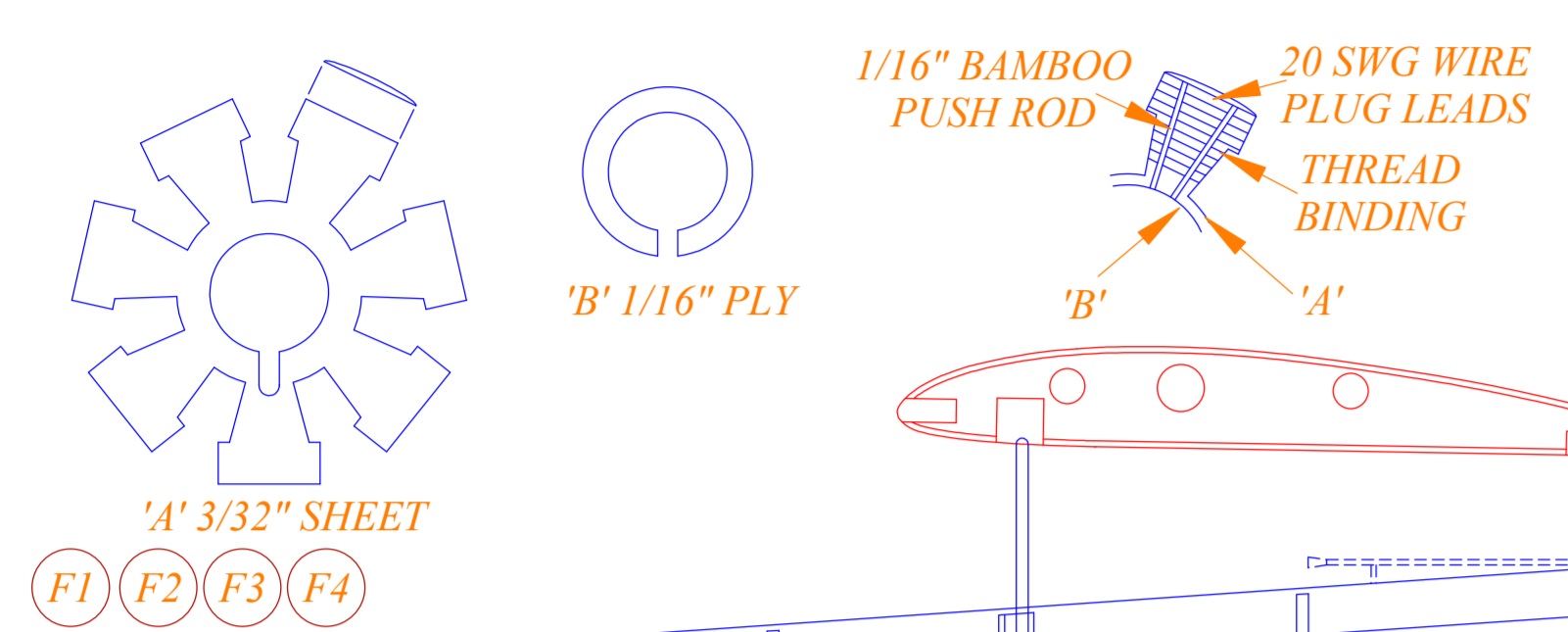
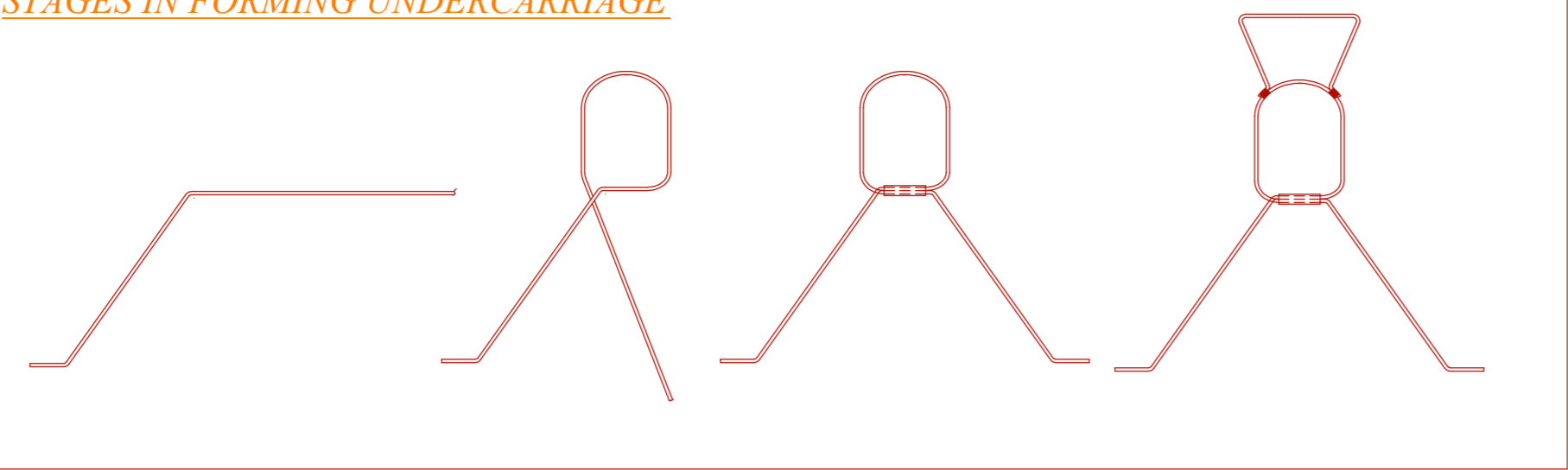

- FORMERS**
F1 - 3/8" SHEET
F2 - IMM PLY
F3/4 - 1/8" SHEET
F5 - 1 OFF 1/8" SHEET
F6 - 1 OFF 1/4" SHEET
F7 - 2 OFF 1/16" SHEET
F8 - 1 OFF 1/16" SHEET
F9 - 2 OFF 1/32" SHEET
F10 - 2 OFF 1/16" SHEET
F11 - 1 OFF IMM PLY
F12 - 2 OFF 1/16" SHEET
F13 - 1 OFF 1/16" SHEET
F14 - 1 OFF 1/16" SHEET
F15 - 1 OFF 1/16" SHEET
F16 - 1 OFF 1/16" SHEET
F17 - 1 OFF 1/16" SHEET
F18 - 1 OFF 1/16" SHEET
F19 - 1 OFF 1/16" SHEET
F20 - 1 OFF 1/16" SHEET

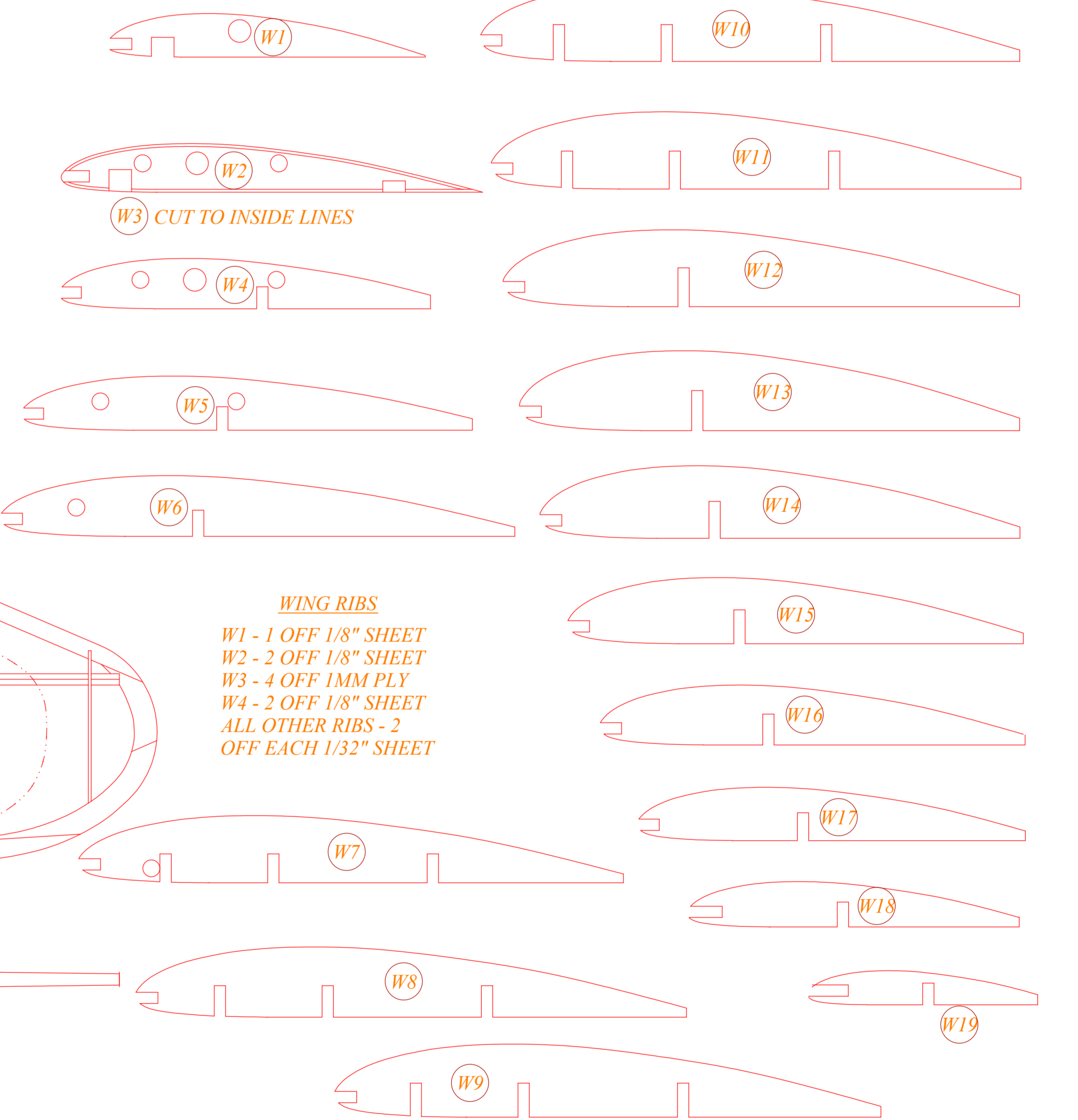
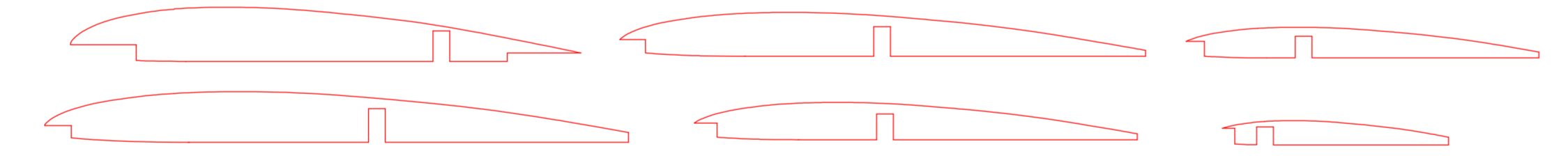
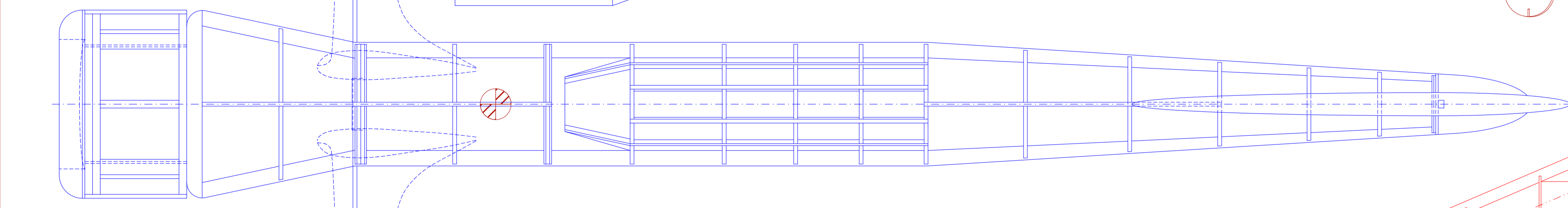

- WING RIBS**
W1 - 1 OFF 1/8" SHEET
W2 - 2 OFF 1/8" SHEET
W3 - 4 OFF IMM PLY
W4 - 2 OFF 1/8" SHEET
ALL OTHER RIBS - 2 OFF EACH 1/32" SHEET

