

RIBS 1/16" SHEET BALSA

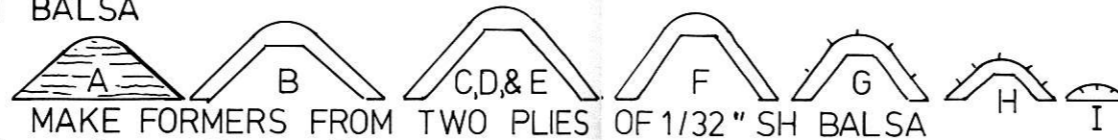

MAKE FORMERS FROM TWO PLYS OF 1/32" SH BALSA

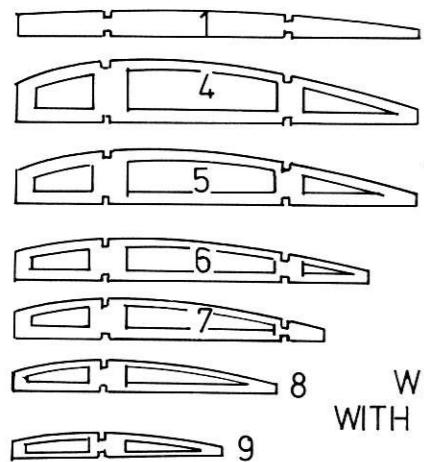

WING STRUTS MADE WITH 1/32" PLYWOOD

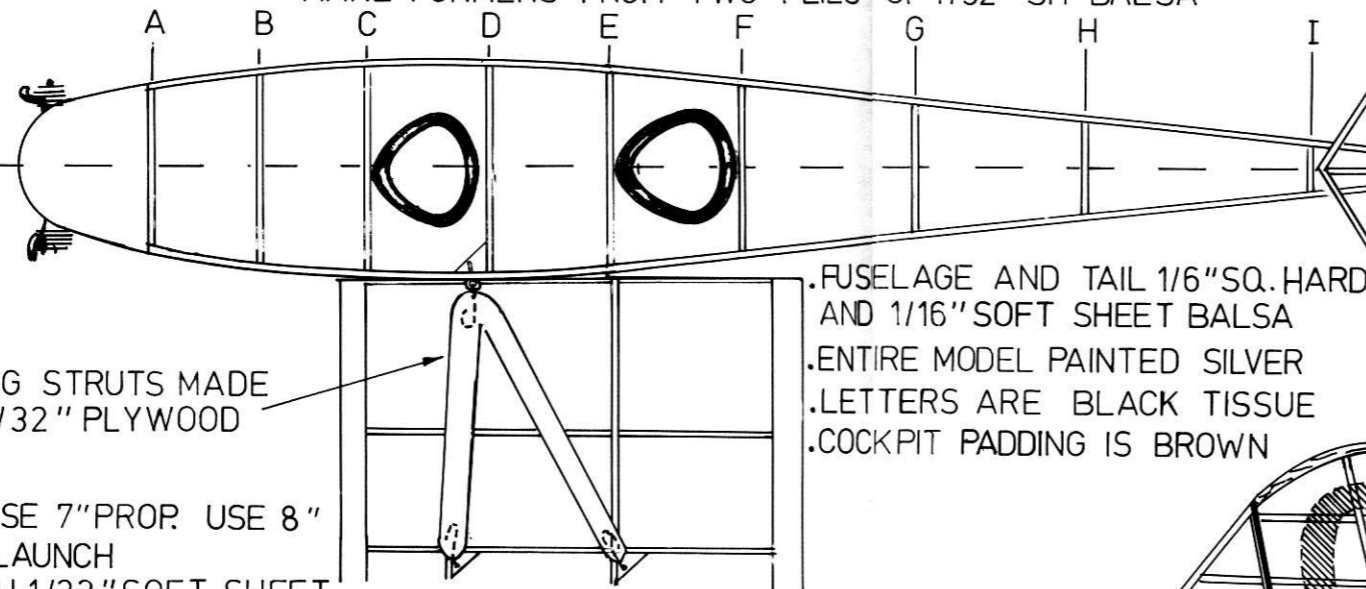

FUSELAGE AND TAIL 1/16" SQ. HARD AND 1/16" SOFT SHEET BALSA  
 ENTIRE MODEL PAINTED SILVER  
 LETTERS ARE BLACK TISSUE  
 COCKPIT PADDING IS BROWN

**PROPELLER**  
 BLADES CUT FROM 16 OZ. PLASTIC CARTON AT 15°

1/8" I.D. ALUM. TUBE

1/8" WOOD DOWEL

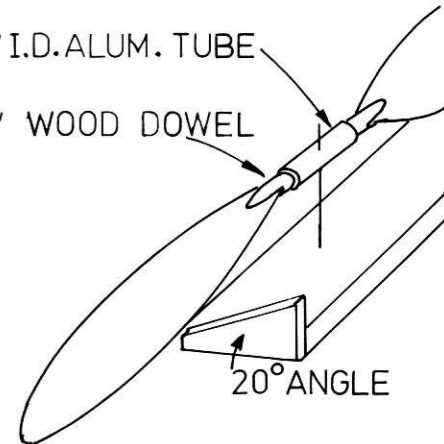

20° ANGLE

FOR R.O.G. USE 7" PROP. USE 8" FOR HAND LAUNCH  
 COVER WITH 1/32" SOFT SHEET

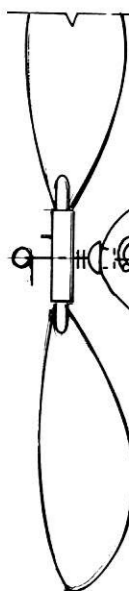

**Constructor's Note:**  
 Build this month's model as a Peanut, or see Page 106 to order the larger size plan!

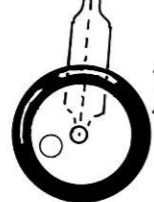

1 1/2" BALSA WHEELS

FOR POWER USE 3 TO 4 LOOPS OF 1/8" FLAT RUBBER 14" LONG

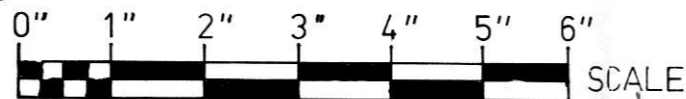

SCALE

1/16" O.D. TUBES

1/64" PLYWOOD  
 .020 WIRE

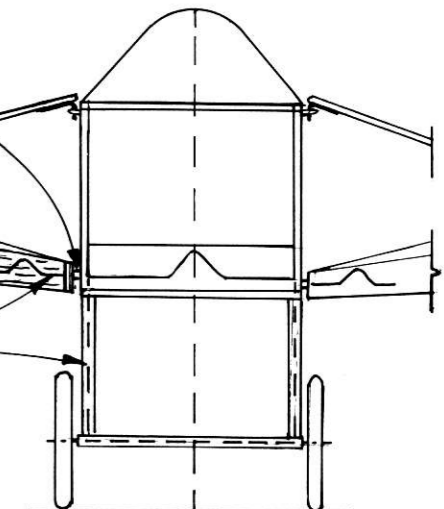

REMOVE CROSS BRACES UNDER FORMERS B THRU H AFTER SHEET BALSA AND STRINGERS ARE IN PLACE TO PROVIDE CLEARANCE FOR RUBBER MOTOR