

STEP ONE

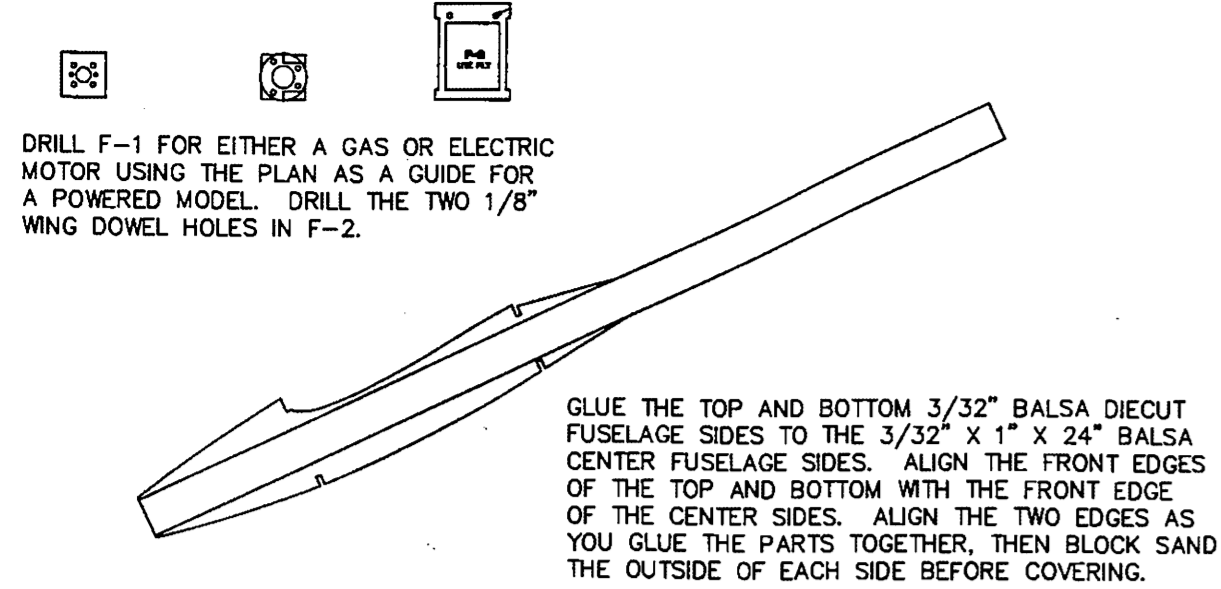

STEP TWO

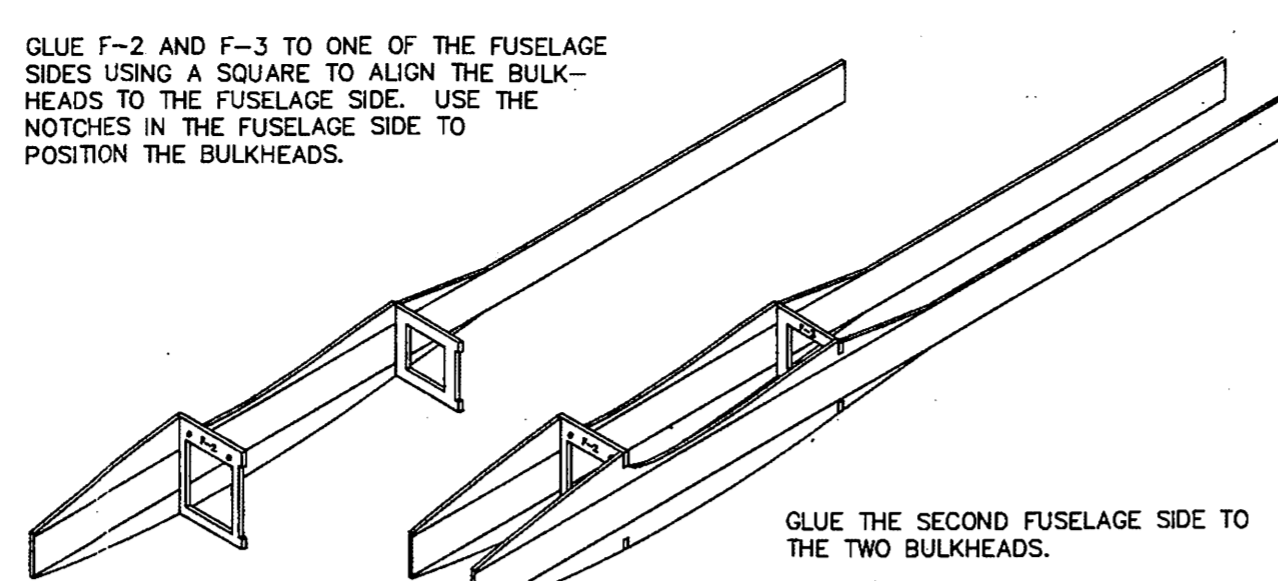

STEP THREE

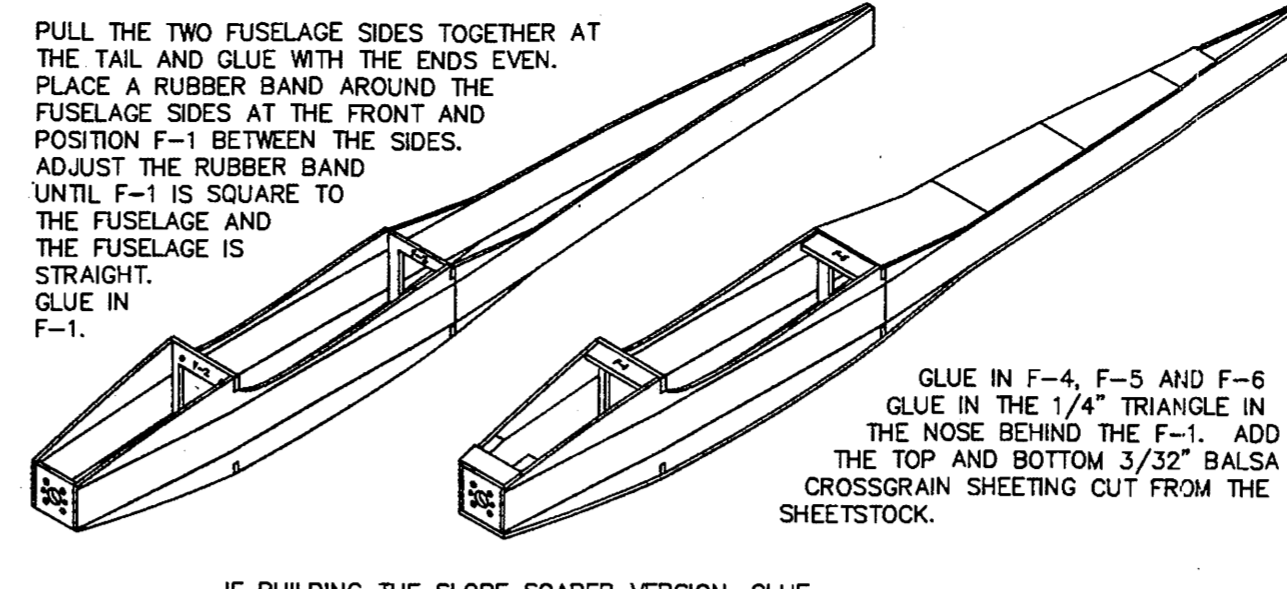

INSTRUCTIONS

TOOLS AND ADHESIVES: TOOLS NEEDED TO BUILD THIS MODEL ARE: X-ACTO KNIFE, PLIERS, DRILL WITH 1/16", 1/8" AND 5/32" DRILL BITS, SCREWDRIVERS, AND MEDIUM AND FINE SANDPAPER. FOR GLUE WE RECOMMEND THE MEDIUM VISCOSITY CYA GLUE FOR ALL WOOD TO WOOD JOINTS. FOR WOOD TO FOAM USE EPOXY OR WHITE GLUE. USE EPOXY TO JOIN THE TWO WING HALVES.

STEP ONE: PREPARE AND DRILL F-1 DEPENDING ON HOW THE MODEL IS TO BE POWERED. USE THE PLAN AS A GUIDE FOR THE GAS ENGINE MOTOR MOUNT OR THE SPEED 400 MOUNT AND COOLING PATTERN. IF BUILDING THE GLIDER, NO HOLES ARE NEEDED. DRILL TWO 1/8" HOLES IN F-2 FOR THE WING MOUNT DOWELS. GLUE THE TOP AND BOTTOM FUSELAGE 3/32" Balsa Diecuts TO EACH OF THE TWO 3/32" x 1" x 24" Balsa SHEETS TO MAKE THE COMPLETE FUSELAGE SIDES.

STEP TWO: GLUE F-2 AND F-3 TO ONE OF THE FUSELAGE SIDES USING A SQUARE TO KEEP THEM ALIGNED. GLUE ON THE SECOND FUSELAGE SIDE USING THE TABS AND NOTCHES FOR POSITION.

STEP THREE: PULL THE FUSELAGE SIDES TOGETHER AT THE REAR, ALIGN THE EDGES, AND GLUE. USE THE TOP VIEW OF THE FUSELAGE TO CHECK ALIGNMENT. PUT A RUBBER BAND AROUND THE SIDES AT THE FRONT AND POSITION F-1. CHECK THE ALIGNMENT AND GLUE F-1 IN PLACE. GLUE F-4, F-5 AND F-6 IN PLACE FOLLOWED BY THE 3/32" Balsa CROSSGRAIN SHEETING TOP AND BOTTOM. GLUE THE 1/4" TRIANGLE IN THE CORNERS OF THE NOSE. CARVE THE NOSE TO MATCH THE ELECTRIC MOTOR SPINNER, GAS MOTOR MOUNT OR THE GLIDER'S NOSE BLOCK.

STEP FOUR: ASSEMBLE THE AILERON LINKAGE FROM THE TWO SHORT PIECES OF 1/16" WIRE AND BRASS TUBES. SOLDER THE BRASS TUBE AILERON ARMS TO THE WIRES, CRIMP THE ENDS AND DRILL WITH A 1/16" DRILL. SLOT THE INBOARD SECTIONS OF THE AILERONS FOR THE LINKAGE, THEN GLUE THE LINKAGE INTO THE SLOTS. GLUE THE 1/8" x 1/4" STRIPS TO THE TRAILING EDGE OF THE FOAM WING HALVES. GLUE THE AILERON LINKAGE TO THE WING PANELS. EPOXY THE TWO WING HALVES TOGETHER, UPSIDE DOWN, FLAT ON THE BENCH. SAND OFF THE FLASHING ALONG THE LEADING EDGE AND THE SURFACE BUMPS WITH FINE SANDPAPER, THEN VACUUM OFF THE DUST. APPLY A STRIP OF 3/4" NYLON FILAMENT STRAPPING TAPE FROM TIP TO TIP, TOP AND BOTTOM OF THE WING AS SHOWN ON THE PLAN. FIT THE AILERONS AND COVER THE WING WITH LOW TEMPERATURE COVERING FILM. HINGE THE AILERONS WITH THE FIGURE 8 HINGES AND HEAVY THREAD. SAND, COVER AND HINGE THE RUDDER AND FIN, STABILIZER AND ELEVATOR. MAKE THE FUSELAGE HATCH WITH THE 3/32" Balsa HATCH AND HATCH TAB USING THE PLAN AS A GUIDE. COVER THE FUSELAGE.

STEP FIVE: CENTER THE WING IN THE FUSELAGE AND HOLD IT FIRMLY IN PLACE WHILE DRILLING THE TWO WING DOWEL HOLES USING THE HOLES IN F-2 AS A GUIDE. USE A LONG DRILL, PIECE OF WIRE OR SHARPENED BRASS TUBE TO DRILL THE HOLES. EPOXY IN THE 3" LENGTHS OF 1/8" DOWEL. DRILL TWO 1/16" HOLES THROUGH THE WING TRAILING EDGE AND F-5 AND INSTALL THE TWO #4 SM SCREWS. REMOVE THE SCREWS AND HARDEN THE HOLES WITH A DROP OF CYA.

FINISH AND RADIO INSTALLATION: APPLY ANY TRIM OR DECORATIONS BEFORE ASSEMBLING THE MODEL. GLUE IN THE TWO LITE PLY SERVO RAILS USING THE PLAN AS A GUIDE. INSTALL THE SERVOS USING THE MANUFACTURER'S GROMMETS AND SCREWS. BEND THE TWO 1/16" WIRE PUSHRODS USING THE PLAN AS A GUIDE. CUT AWAY THE COVERING ON THE TAIL PARTS WHERE THERE IS A GLUE JOINT AND GLUE THE RUDDER AND STABILIZER TO THE FUSELAGE. INSTALL THE PUSHRODS AND MOUNT THE CONTROL HORNS. MAKE THE AILERON PUSHRODS AND ATTACH TO THE AILERON LINKAGE. WITH THE WING HELD ABOVE THE FUSELAGE, INSERT THE ENDS OF THE AILERON PUSHRODS INTO THE SERVO WHEEL. PUSH THE WIRES IN AS THE WING LOWERS INTO THE SADDLE. SLIDE THE WING DOWELS INTO F-2 AND INSERT THE TWO SCREWS TO SECURE THE WING. ADJUST THE AILERON LINKAGE.

FLYING: SET THE CONTROL THROWS PER THE PLAN. CHARGE THE BATTERIES, START THE ENGINE OR HEAD FOR THE HILL. THE SIMPLE 400 IS A CLEAN DESIGN THAT WILL GET THE MOST OUT OF POWER USED. IT GLIDES FURTHER WHEN LANDING THAN OTHER SIMPLE SERIES DESIGNS. THE SIMPLE 400 WAS DESIGNED FOR AEROBATICS, ONE DESIGN RACING OR JUST SPORT FLYING. THE RUDDER WAS ADDED FOR SNAPS AND SPINS, KNIFE EDGE AND HAMMERHEADS AT THE SLOPE OR THE FLYING FIELD.

STEP FOUR

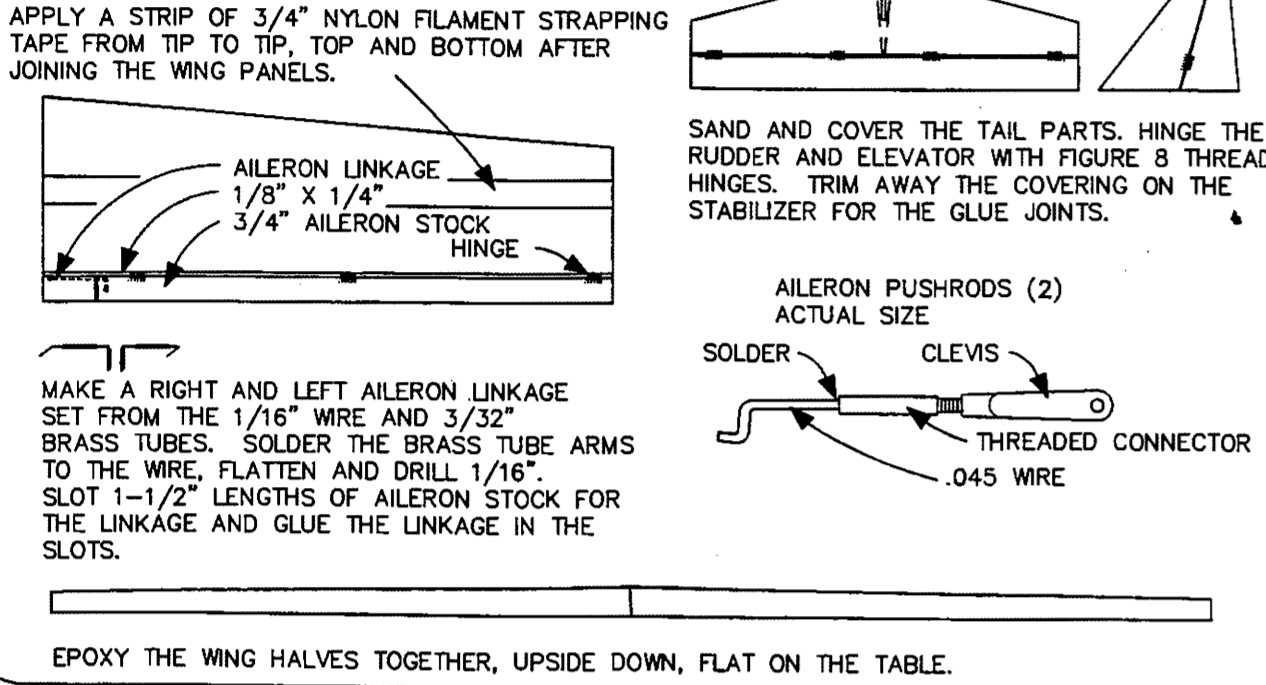

STEP FIVE

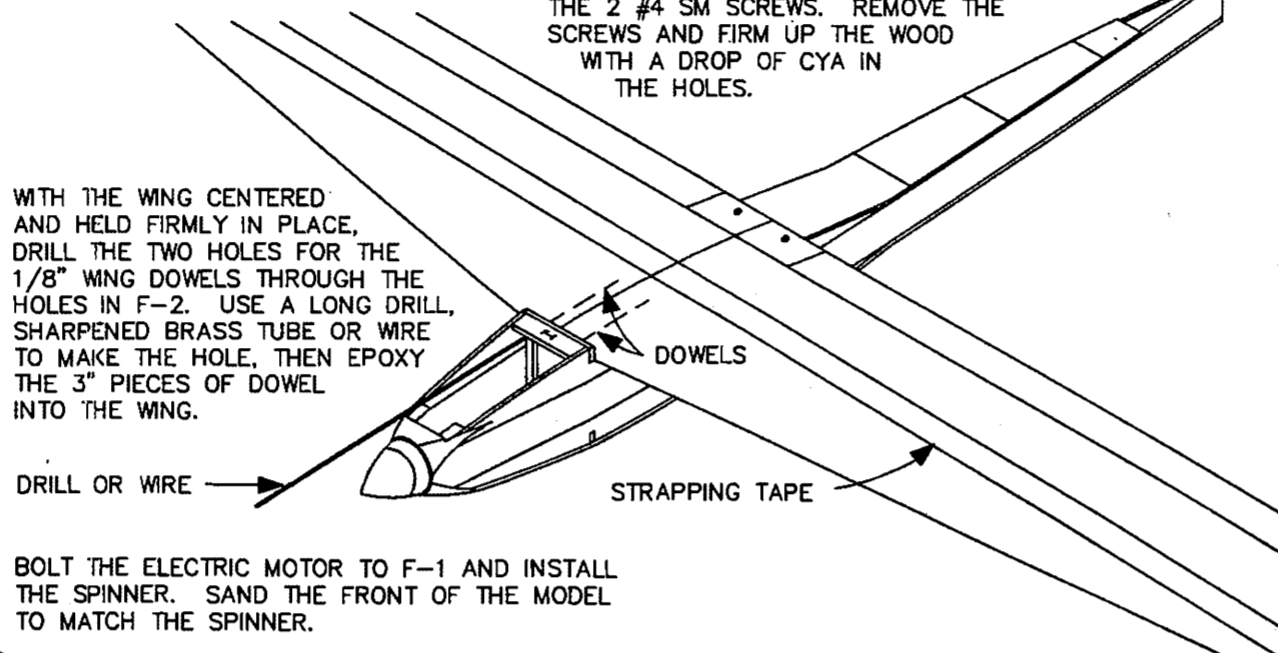

STEP SIX

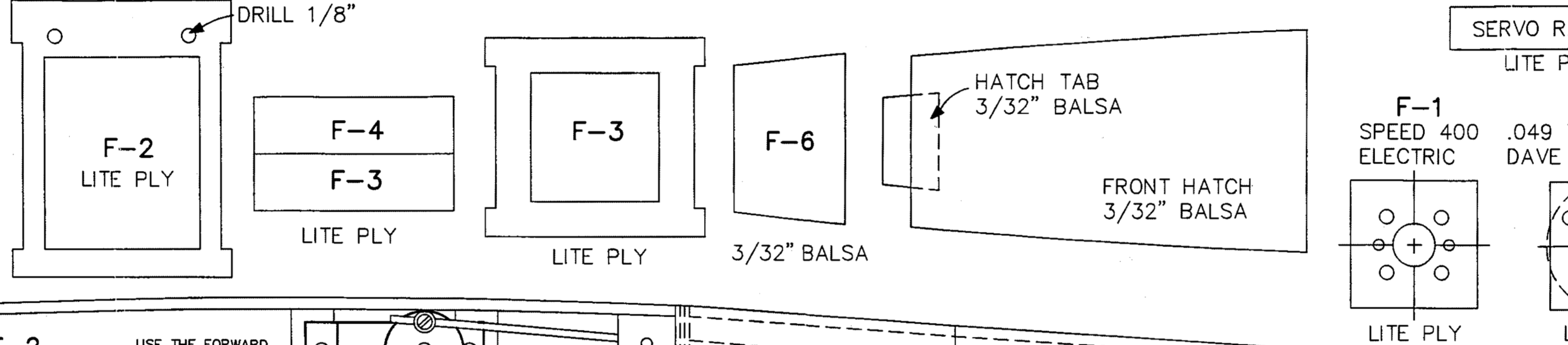
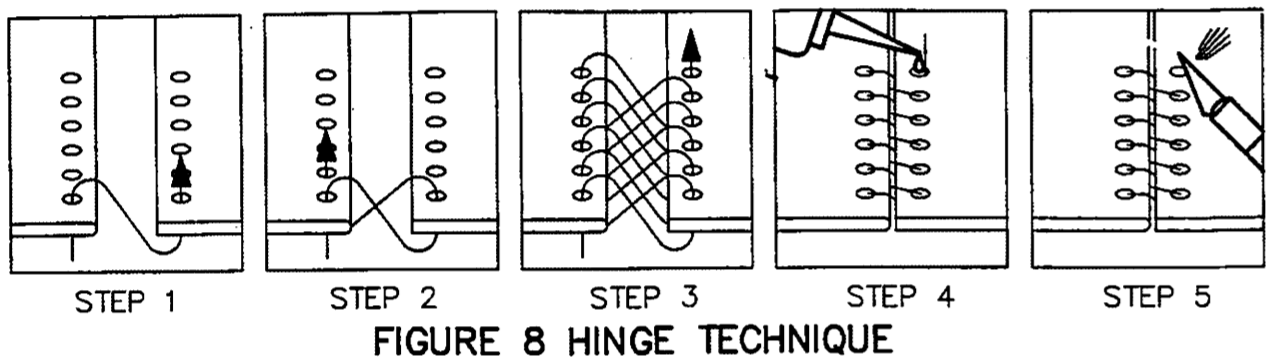
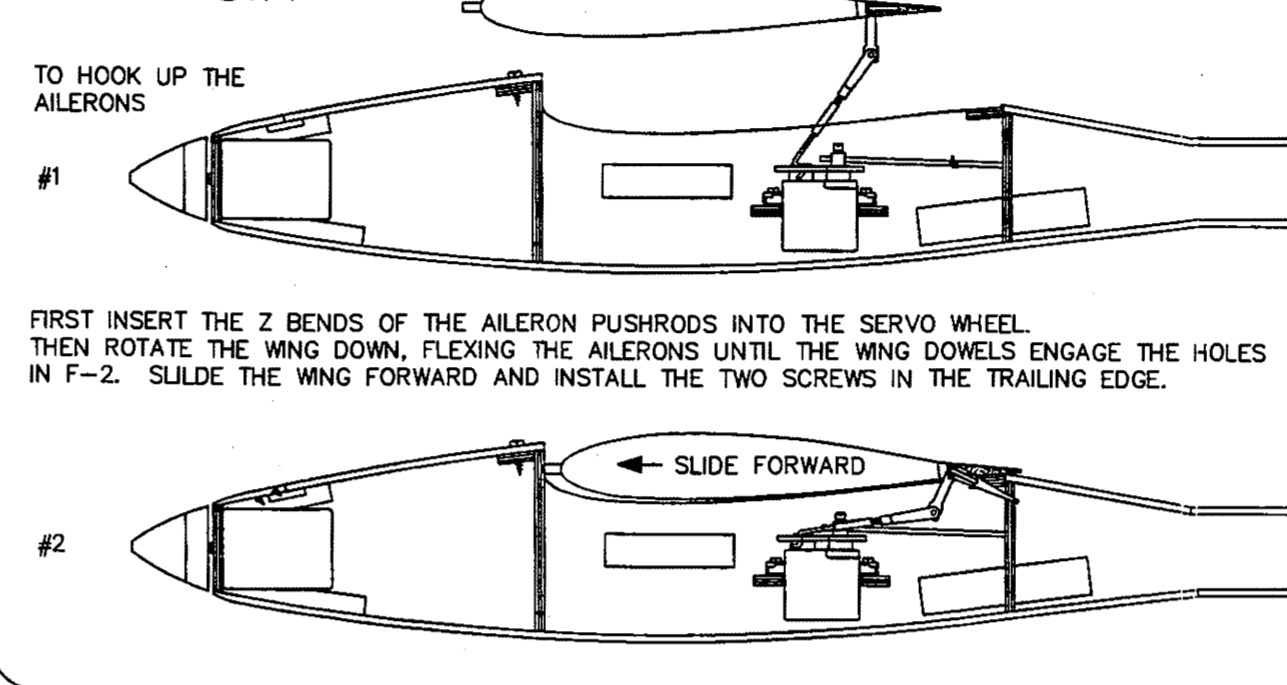

GAS POWER

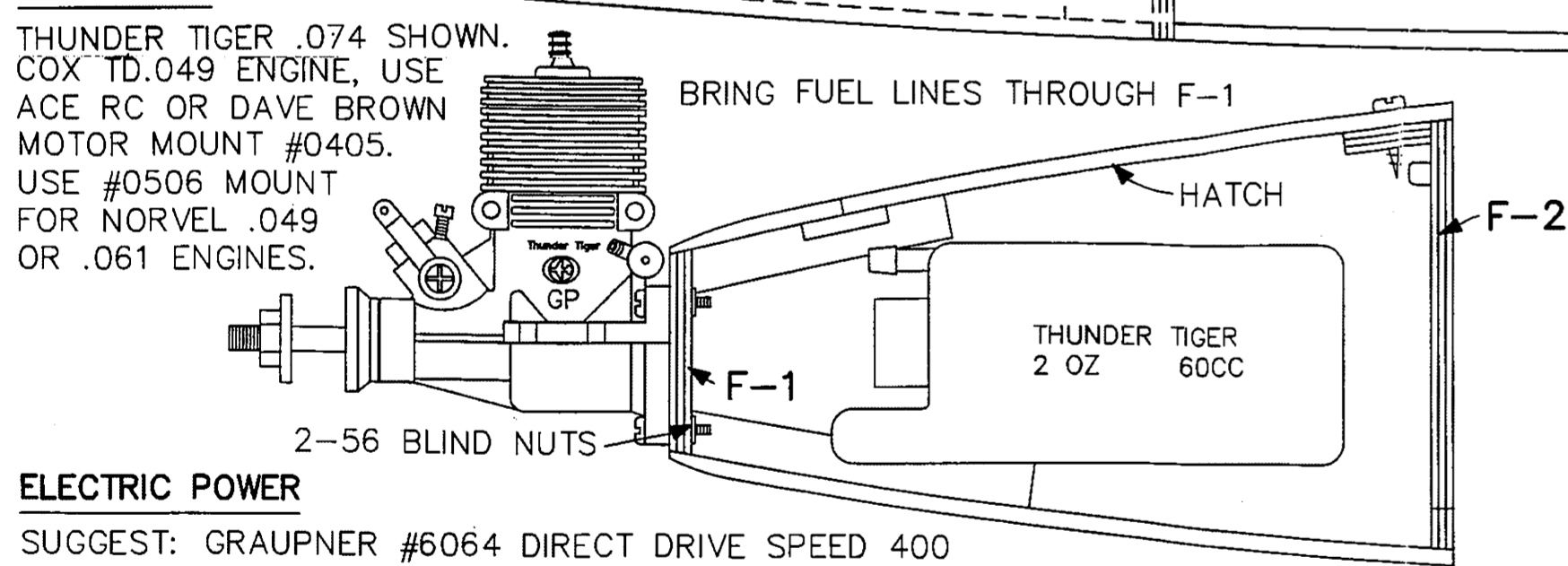

ELECTRIC POWER

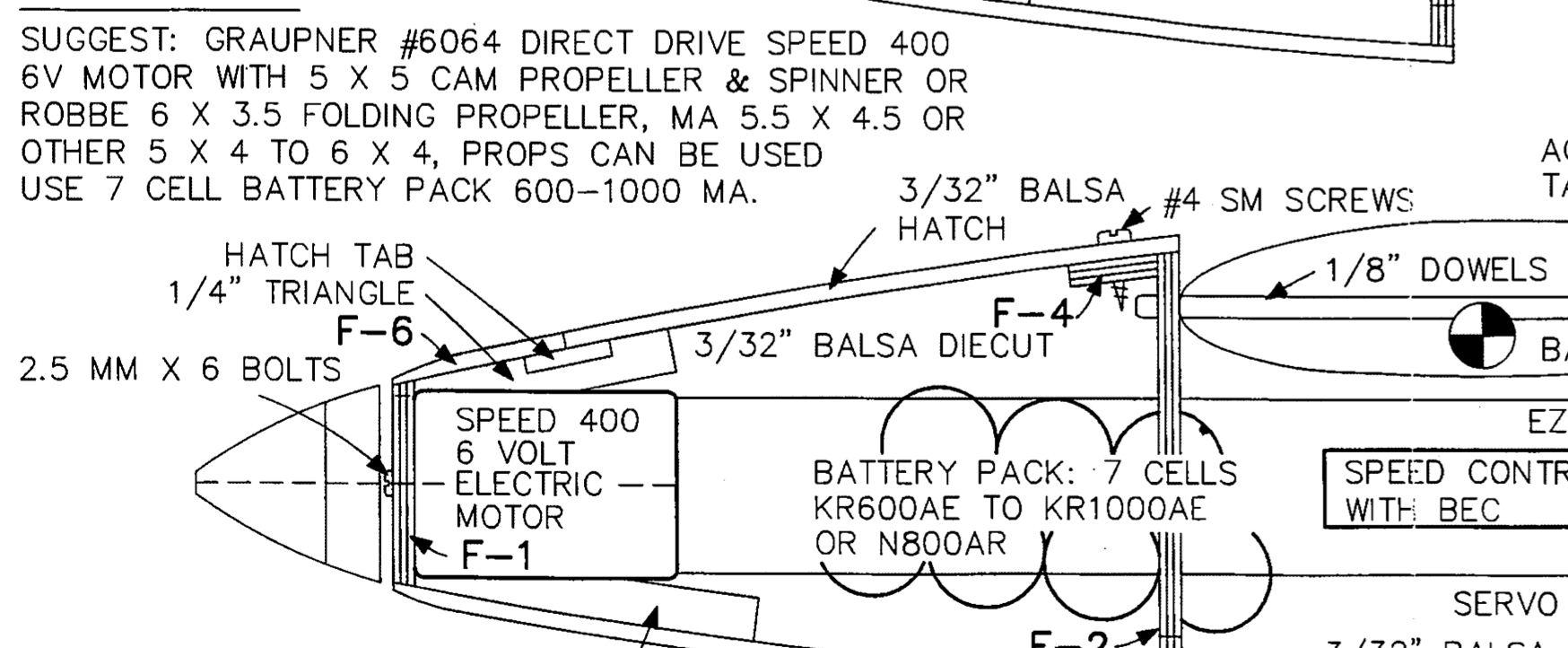

AILERON LINKAGE

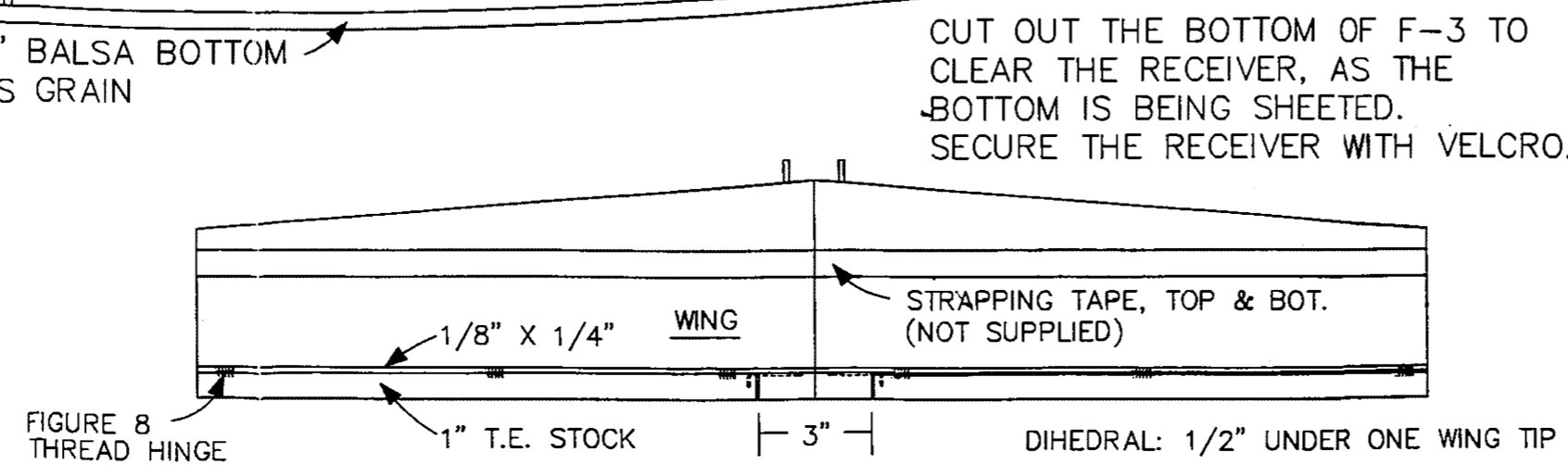
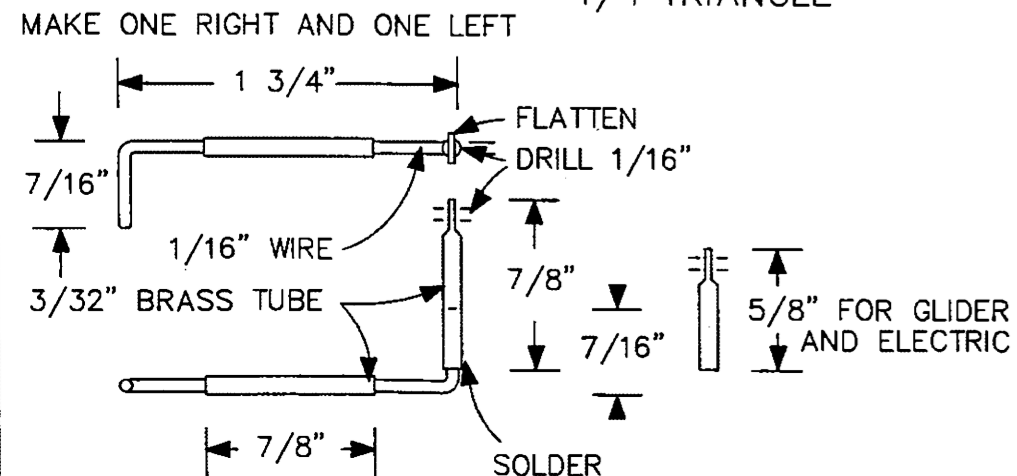

CONTROL MOVEMENT

AILERONS: 3/16" UP AND DOWN
ELEVATOR: 1/4" UP AND DOWN

SIMPLE 400

WINGSPAN 34"
WING AREA 180 SQ. IN.
LENGTH 26 1/2"
WEIGHT 11 OZ.
ENGINE .049-.074 GAS
SPEED 400 ELECTRIC
RADIO 2-4 CHANNEL

DESIGNED AND DRAWN BY FRED REESE

©1997 ACE RC MFG.

ACE R/C

116 W 19 ST, POB 472, HIGGINSVILLE, MO. 64037-0472