

SORT-A-SCALE FOKKER

DESIGNED BY
HENRY A. HAFKKE
WINGSPAN 56 IN.
LENGTH 44 IN.
POWER .35-40 OR .46 4 CYCLE
WEIGHT 4 1/2 - 5 LBS.
PLATE 1 OF 2

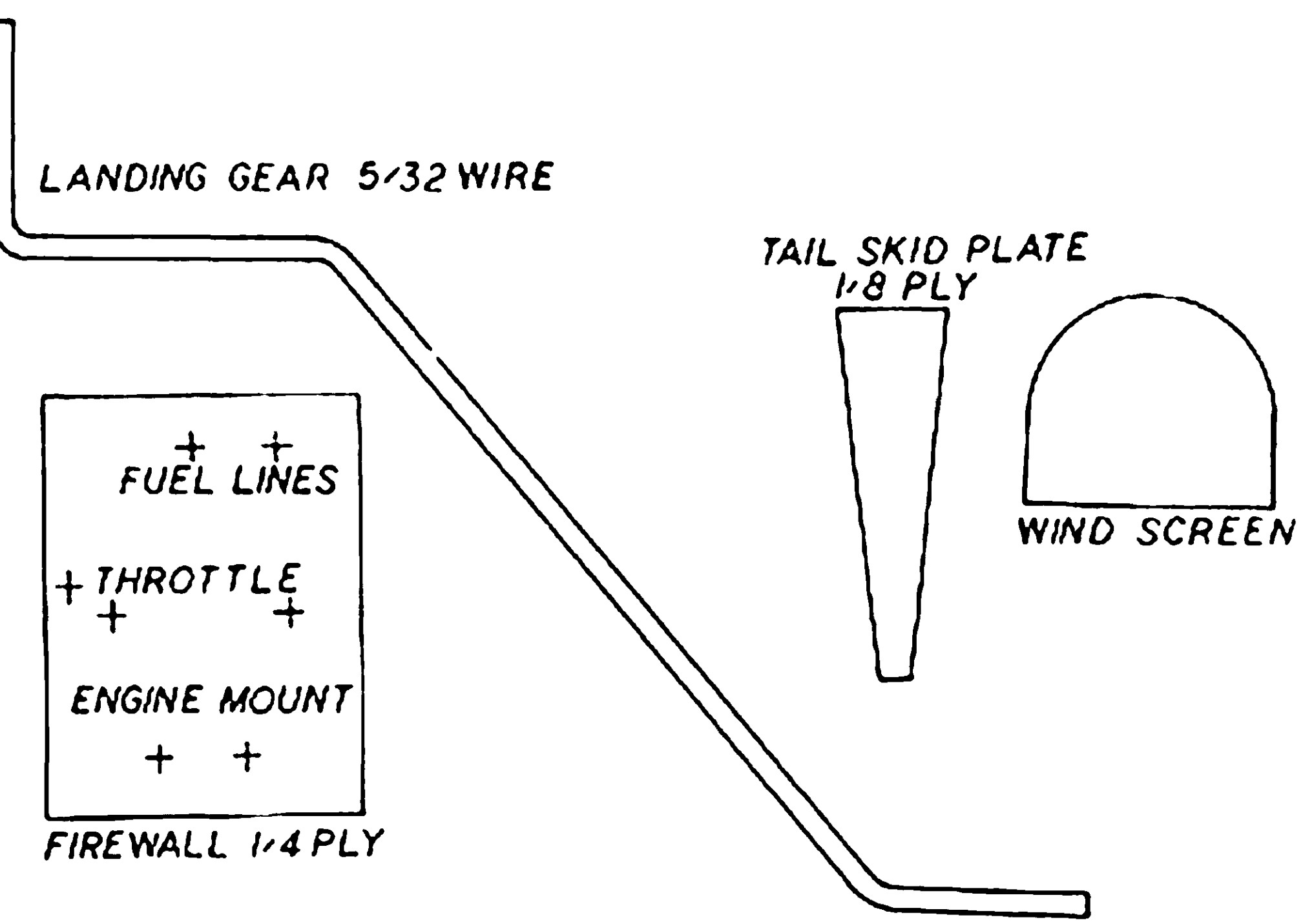

4 CYCLE INSTALLATION
 MOVE FIREWALL 11/16 BACK FROM FRONT
 USE J'TEC MOUNT
 USE SS-6 FUEL TANK
 ENYA 46-4C USED ON PROTOTYPE
 CUT AWAY FUSELAGE SIDES FORWARD OF FIREWALL IF DESIRED

FOR CONVENTIONAL LANDING GEAR
 MOVE LG. MOUNT BLOCKS TO POSITION SHOWN ABOVE. ANGLE GEAR FORWARD AS SHOWN

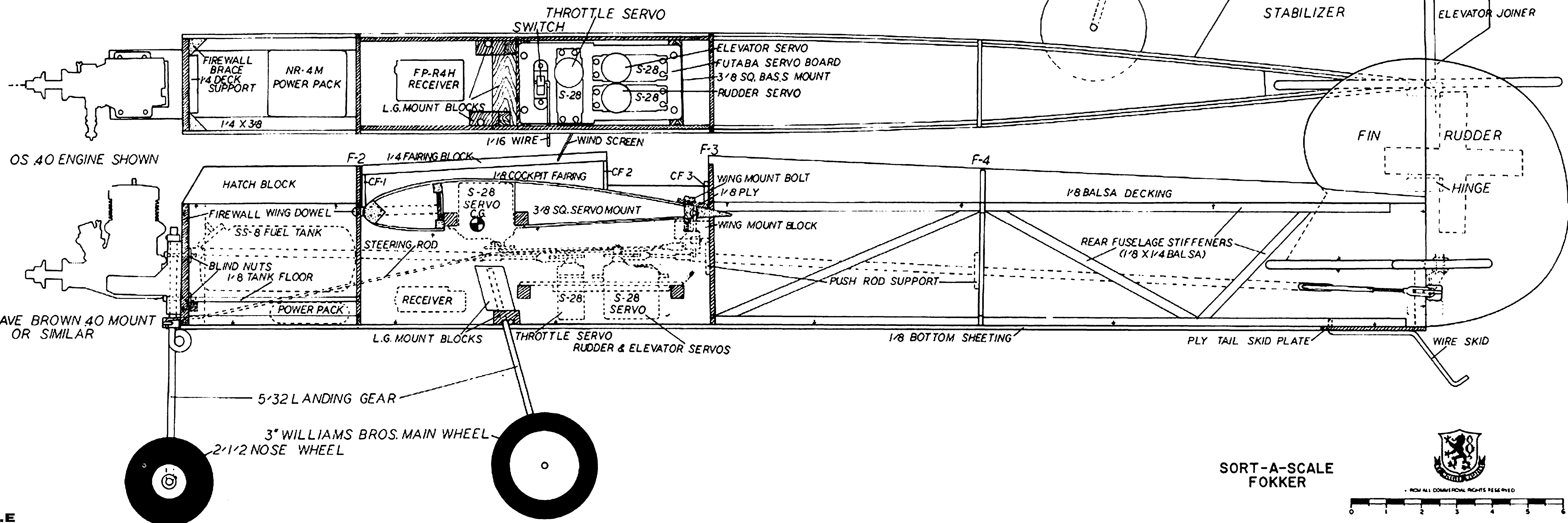

SORT-A-SCALE FOKKER

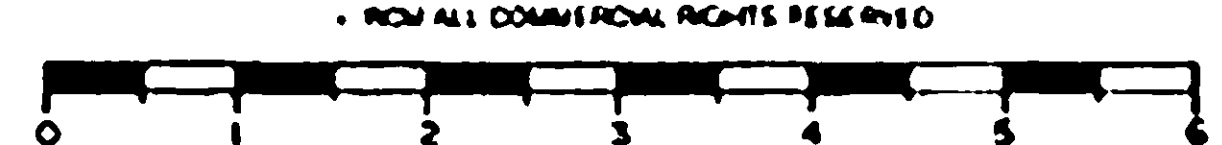

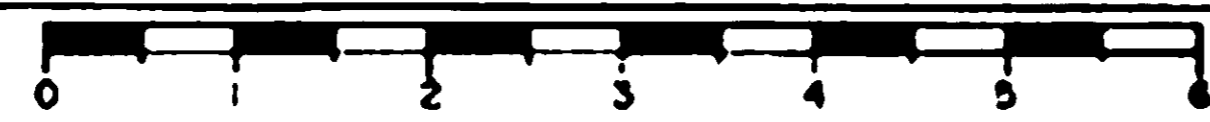
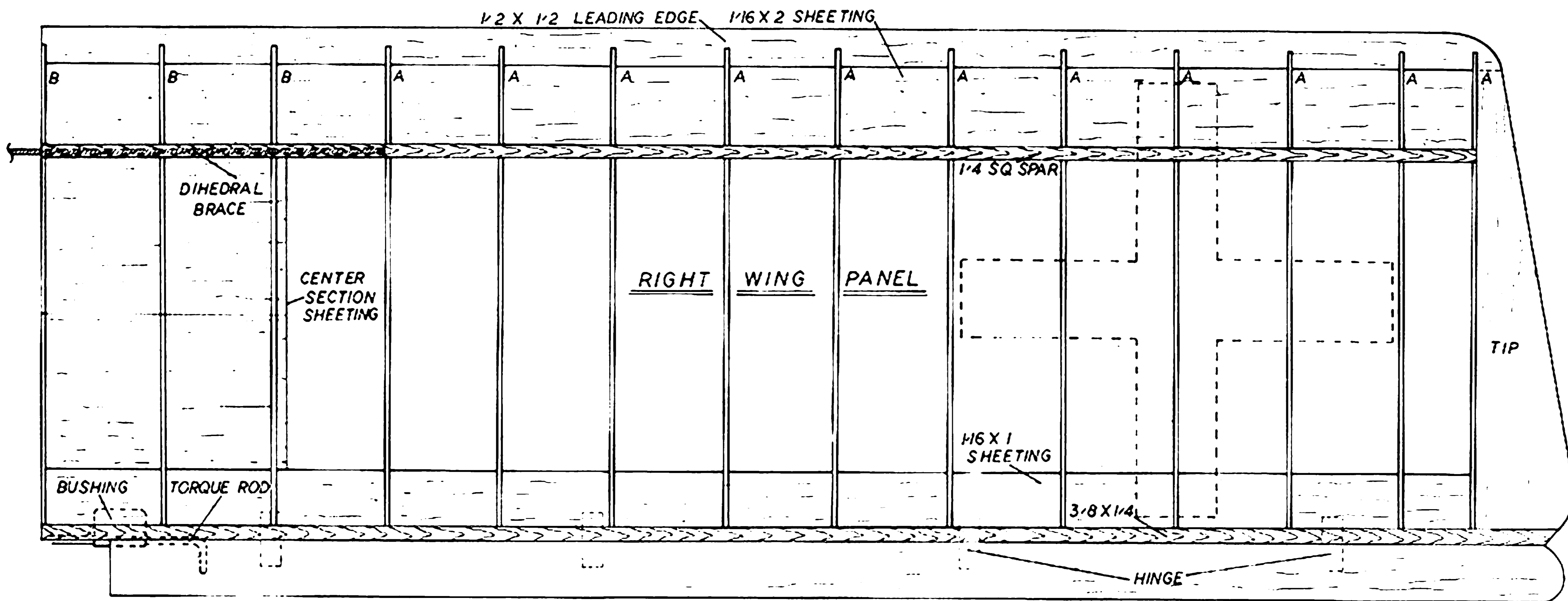

PLATE 2 OF 2 SORT-A- SCALE FOKKER BY HENRY A. HAFFKE

