

NOTE: DIHEDRAL IS 2-1/2" UNDER EACH TIP

NOTE: RIB W-1 1/4" Balsa
RIB W-2 3/16" Balsa
RIB W-4, W-5, W-6, W-7 1/16" Plywood
ALL OTHER RIBS FROM 3/32" Balsa

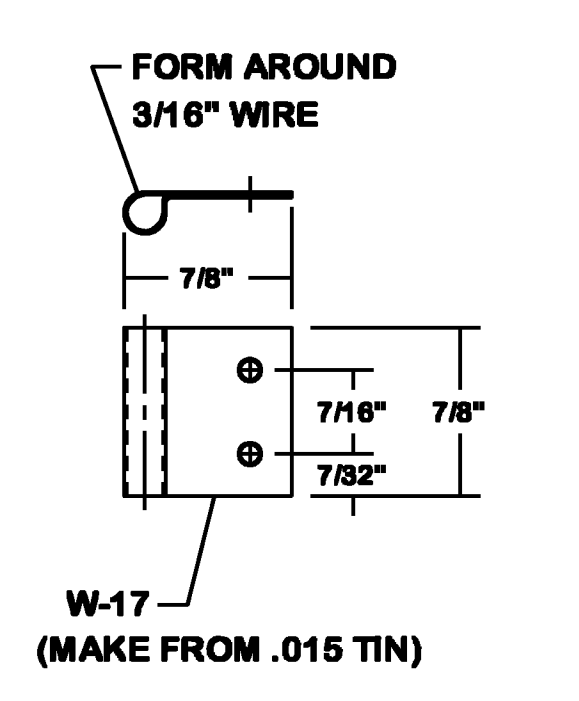

IMPORTANT: RETAIN ALL RIBS IN ONE PIECE AS STAB & ELEVATOR ARE TO BE BUILT AS A UNIT

NOTE: DO NOT USE S7 & S8 RIBS IF SHEET ELEVATORS ARE CONTEMPLATED

NOTE: THIS CENTER SECTION AND ELEVATORS CAN BE MADE FROM 1/2" x 2" SHEET IF BUILD UP STRUCTURE IS NOT DESIRED

HINGE LINES - HINGE TO SUIT NYLON STRIP OR WILLIAMS BROTHERS OR ROUND OFF LEADING EDGE IF THREAD IS USED

NOTE: REAR EDGE OF TOP AND BOTTOM MAIN SHEETS IF SOLID ELEVATORS & CENTER SECTION ARE USED

NOTE: BEVEL LEADING EDGE OF ALERONS SO THAT 35" UP TRAVEL AND 25" DOWN TRAVEL IS OBTAINED

AFTER ALERON IS CUT FROM MAIN WING PANEL REMOVE ENOUGH STOCK FROM INBOARD END OF ALERON TO OBTAIN CLEARANCES SHOWN

BASIC STEPS IN CONSTRUCTION OF WING

1 ASSEMBLE BASIC PANELS OVER PLAN-ADD W-15, PLYWOOD DOUBLERS W-4-A, W-4-B, W-5-A & W-5-A THEN ADD LANDING GEAR BLOCK & CLAMP W-17

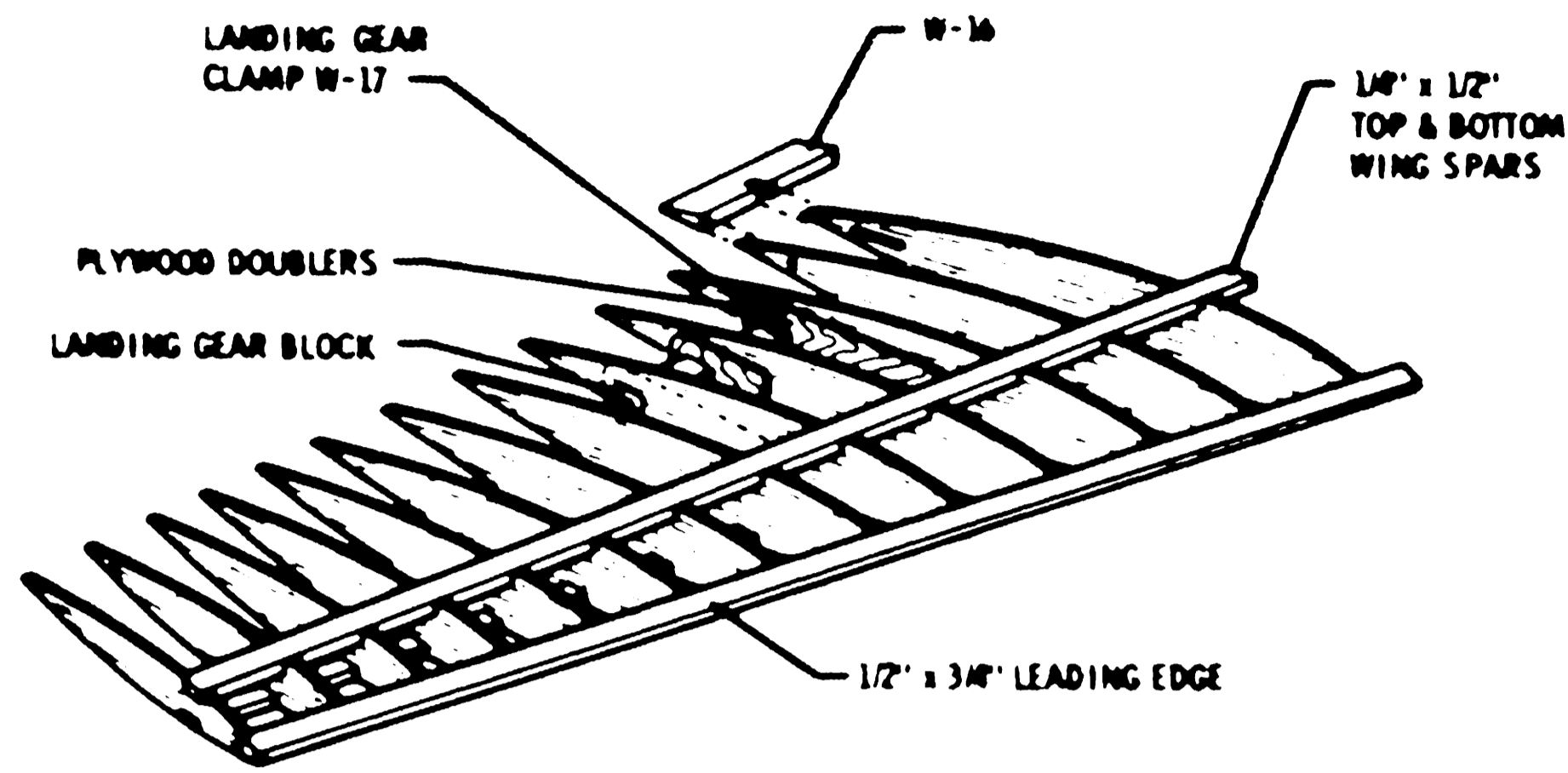

2 BEVEL LEADING EDGE UPPER & LOWER SURFACES PER SECTION H H. THEN SHEET ENTIRE TOP OF PANEL WHILE STILL ON BUILDING SURFACE. WHEN TOP SHEETING IS DRY REMOVE PANEL FROM BUILDING SURFACE, TURN OVER & BEING CAREFUL NOT TO PUT A WARP INTO PANEL WHILE APPLYING SHEETS WHEN DRY ADD TIP BLOCK

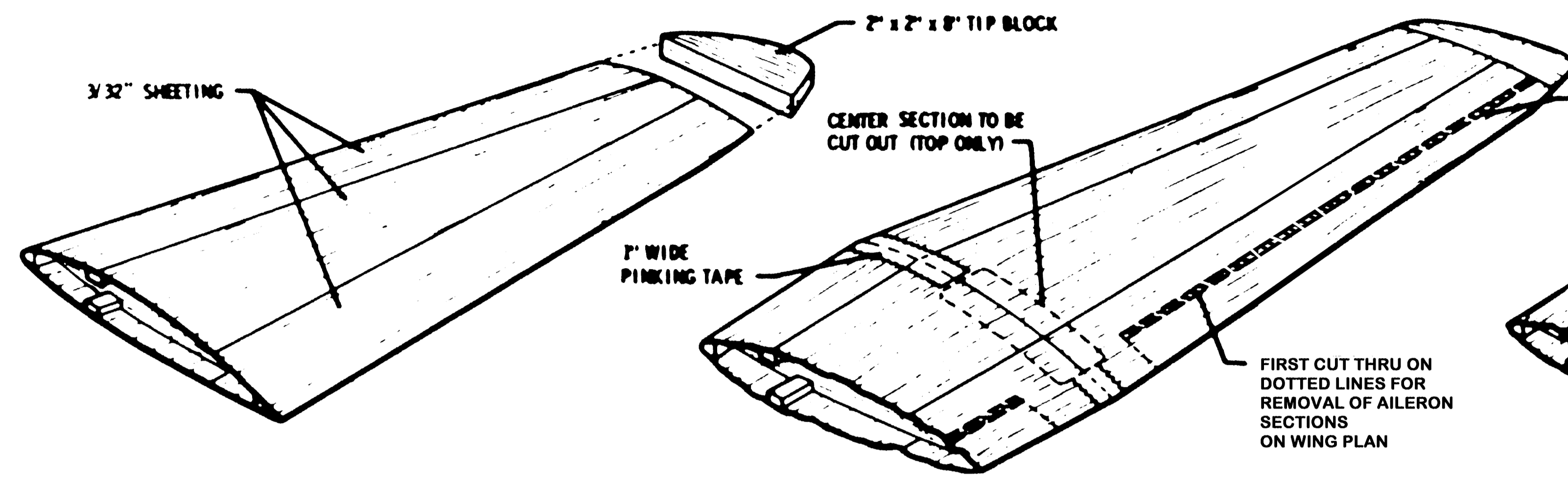

3 BEVEL IN-BOARD END OF EACH PANEL TO ACHIEVE THE PROPER DIHEDRAL: 2-1/2\"/>

THEN CUT OUT REMAINING PORTIONS OF WING PANEL WHICH WILL BE TAKEN UP BY ADDED REAR SPAR & AILERON LEADING EDGE

4 CEMENT SCRAP HINGE BLOCKS IN PLACE ADD REAR SPARS TO MAIN PANELS. WHEN DRY TRIM OFF FLUSH WITH TOP & BOTTOM SURFACES. CEMENT DRIVE WIRE BLOCKS IN PLACE AT INBOARD ENDS OF AILERONS THEN ADD AILERON LEADING EDGES WHEN DRY TRIM OFF FLUSH WITH TOP & BOTTOM OF AILERON (SEE SECTION H H)

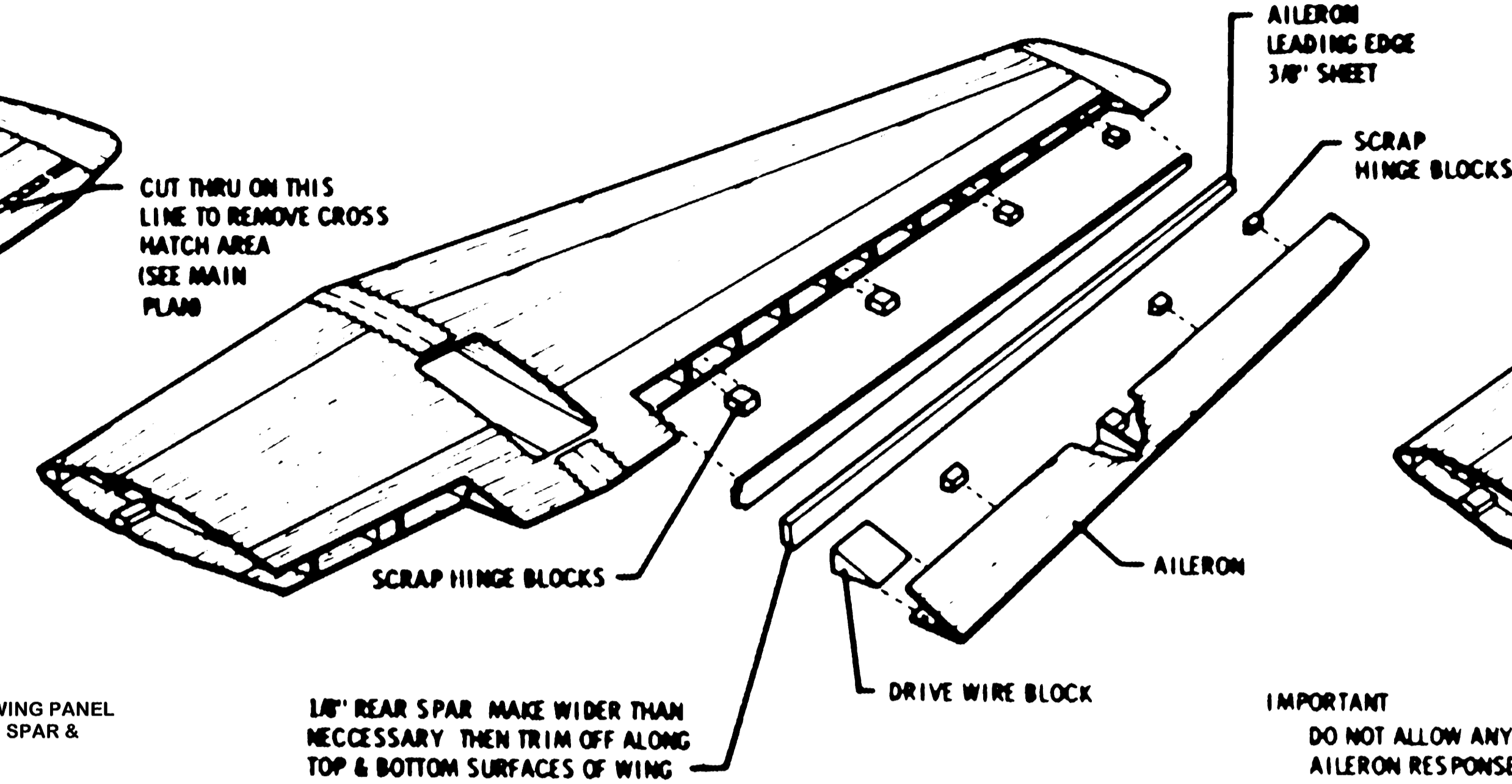

5 SLIDE AILERON DRIVE WIRE ASSEMBLY IN PLACE BY FIRST THREADING THE CENTER LEG OF WIRE THRU HOLE IN RIB W-2, THEN PUSHING THRU SLOT 3 IN RIB W-2. CENTER THE DRIVE ASSEMBLY CAREFULLY AND EPOXY IN PLACE BEING SURE TO APPLY THE GLUE ONLY TO THE BRASS TUBING OF THE ASSEMBLY. NOW BEVEL AILERON LEADING EDGES PER SECTION H H. INSTALL YOUR FAVORITE HINGES (NYLON STRIP HINGES ARE ILLUSTRATED)

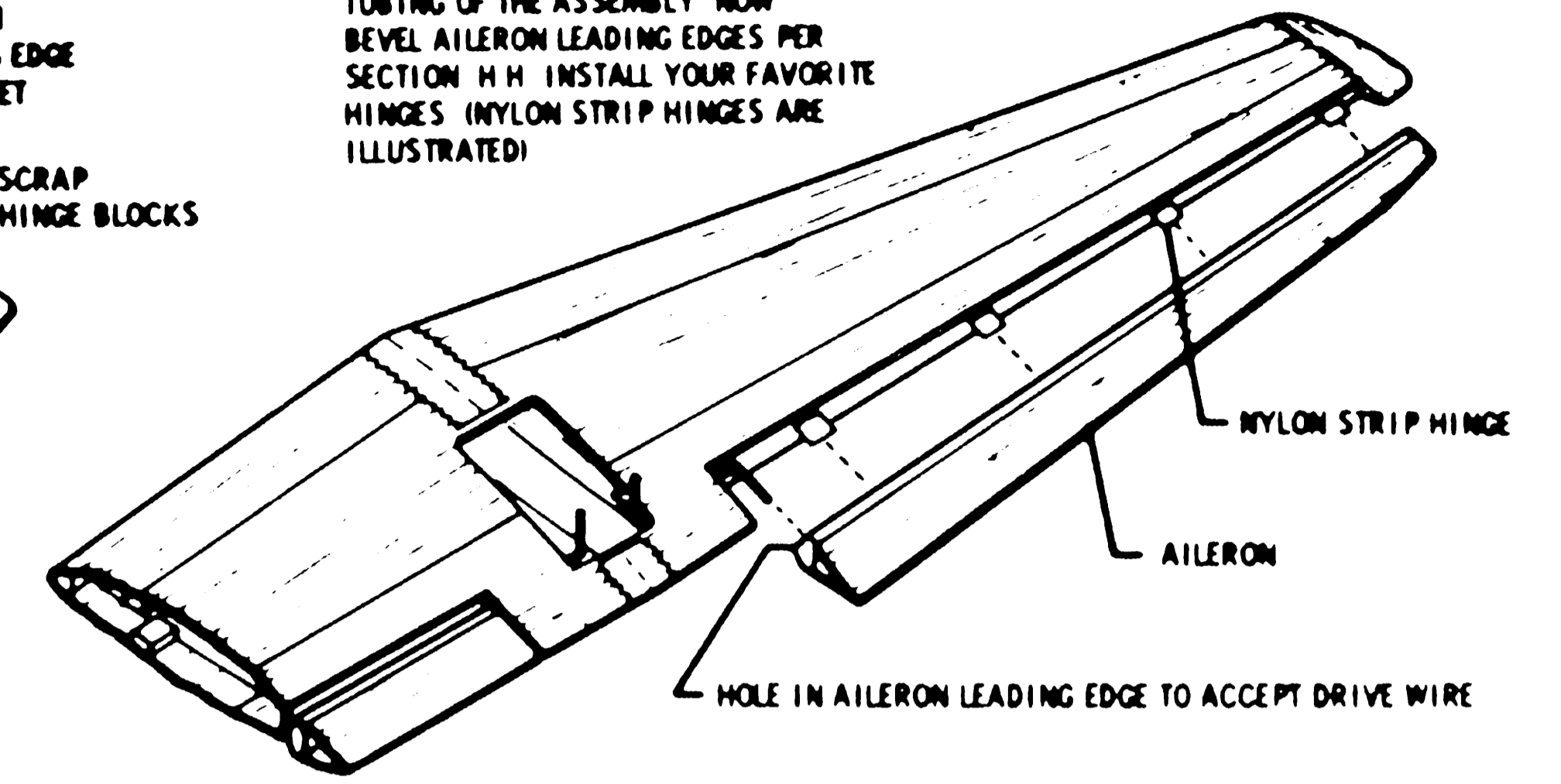

IMPORTANT DO NOT ALLOW ANY VISIBLE GAP BETWEEN AILERON LEADING EDGE AND REAR SPAR. AILERON RESPONSE WILL SUFFER IF THIS CONDITION EXISTS

SEE VIEW "A" FOR FAIRING BLOCK DETAILS

BASIC STEPS IN CONSTRUCTION OF STABILIZER & ELEVATOR ASSEMBLY

1 LAY BOTTOM MAIN SHEET ON FLAT SURFACE. ADD RIBS-ADD TOP MAIN SHEET

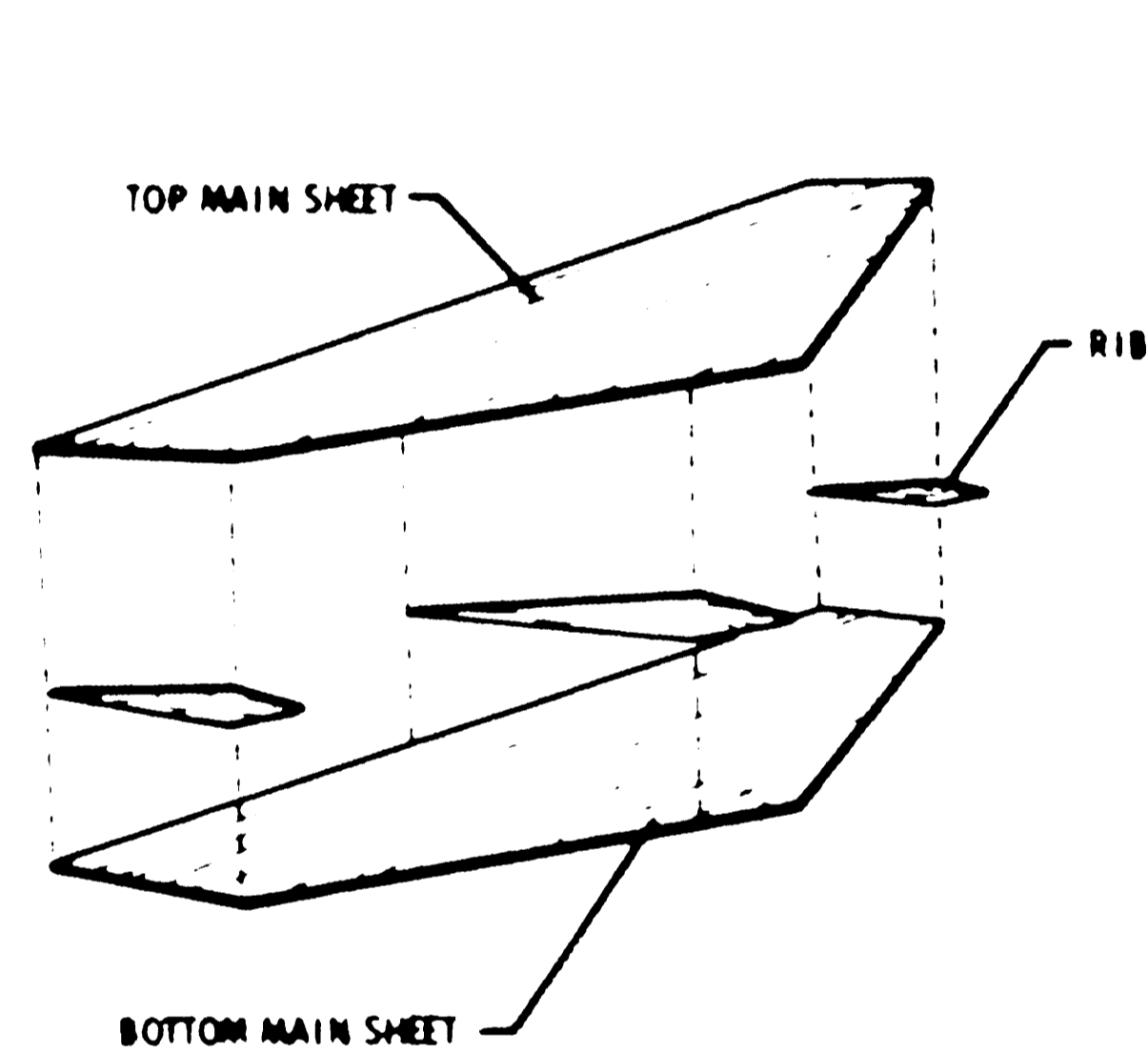

2 ADD TOP & BOTTOM LEADING EDGES ADD TIP BLOCKS

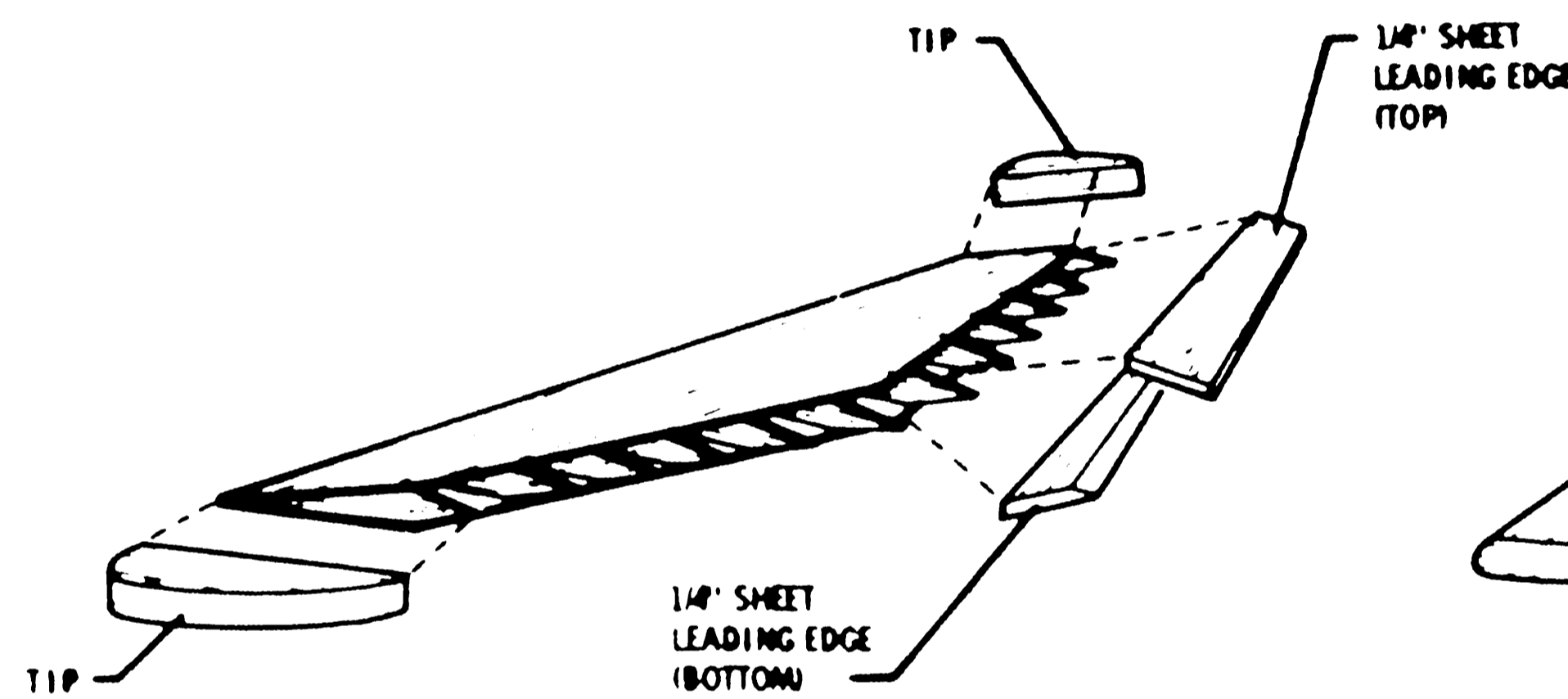

3 SAND AND CONTOUR ENTIRE STAB AND ELEVATOR ASSEMBLY (SEE SECTION G G)

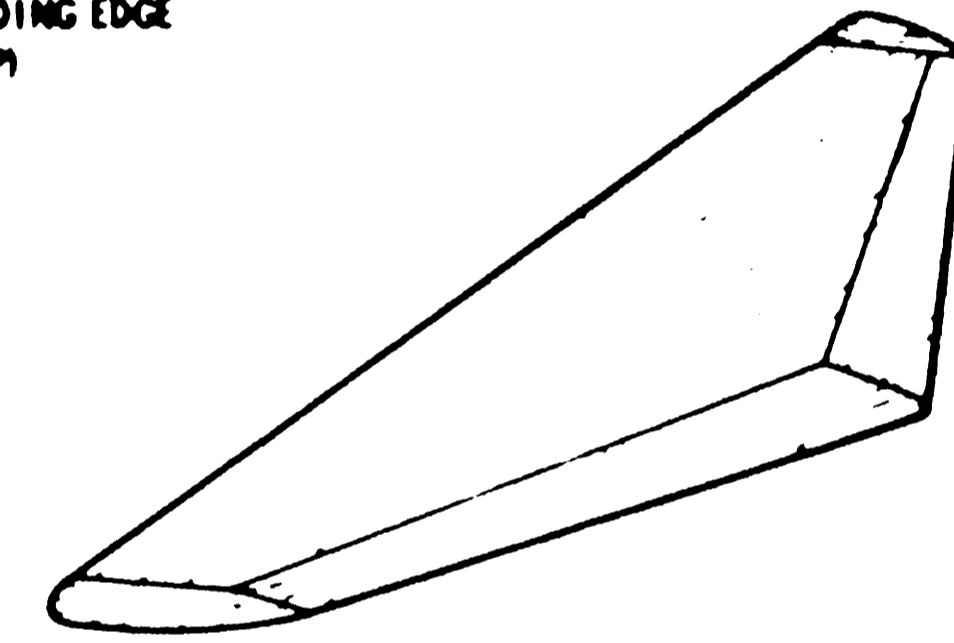

4 CUT OUT ELEVATOR SECTIONS ON LINES INDICATED THEN CUT OUT CENTER SECTION

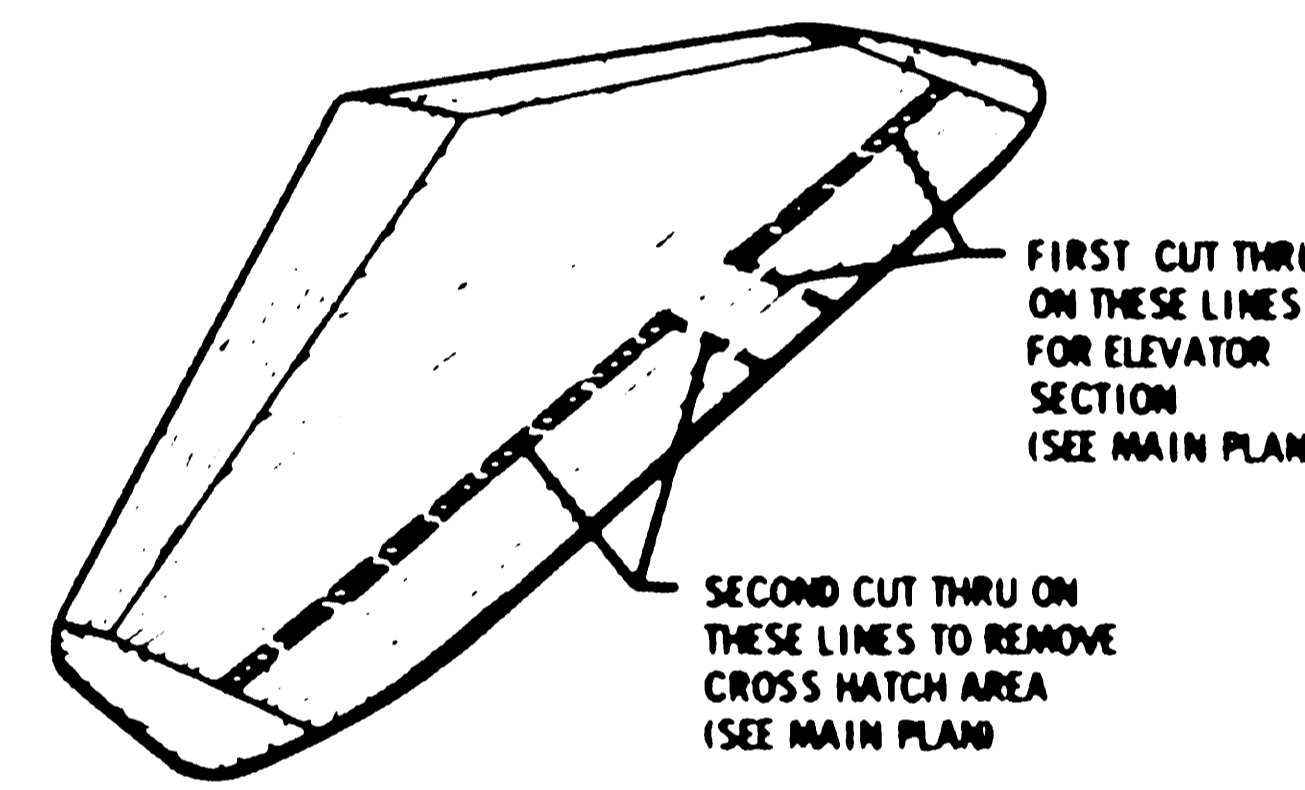

5 INSTALL SCRAP HINGE BLOCK AS SHOWN IN MAIN LAYOUT THEN ADD REAR SPAR. ADD SCRAP HINGE BLOCKS AND HORN WIRE BLOCKS TO ELEVATORS THEN ADD LEADING EDGE CAPS TRIM OFF FLUSH WITH TOP & BOTTOM OF ELEVATORS (SEE SECTION G G)

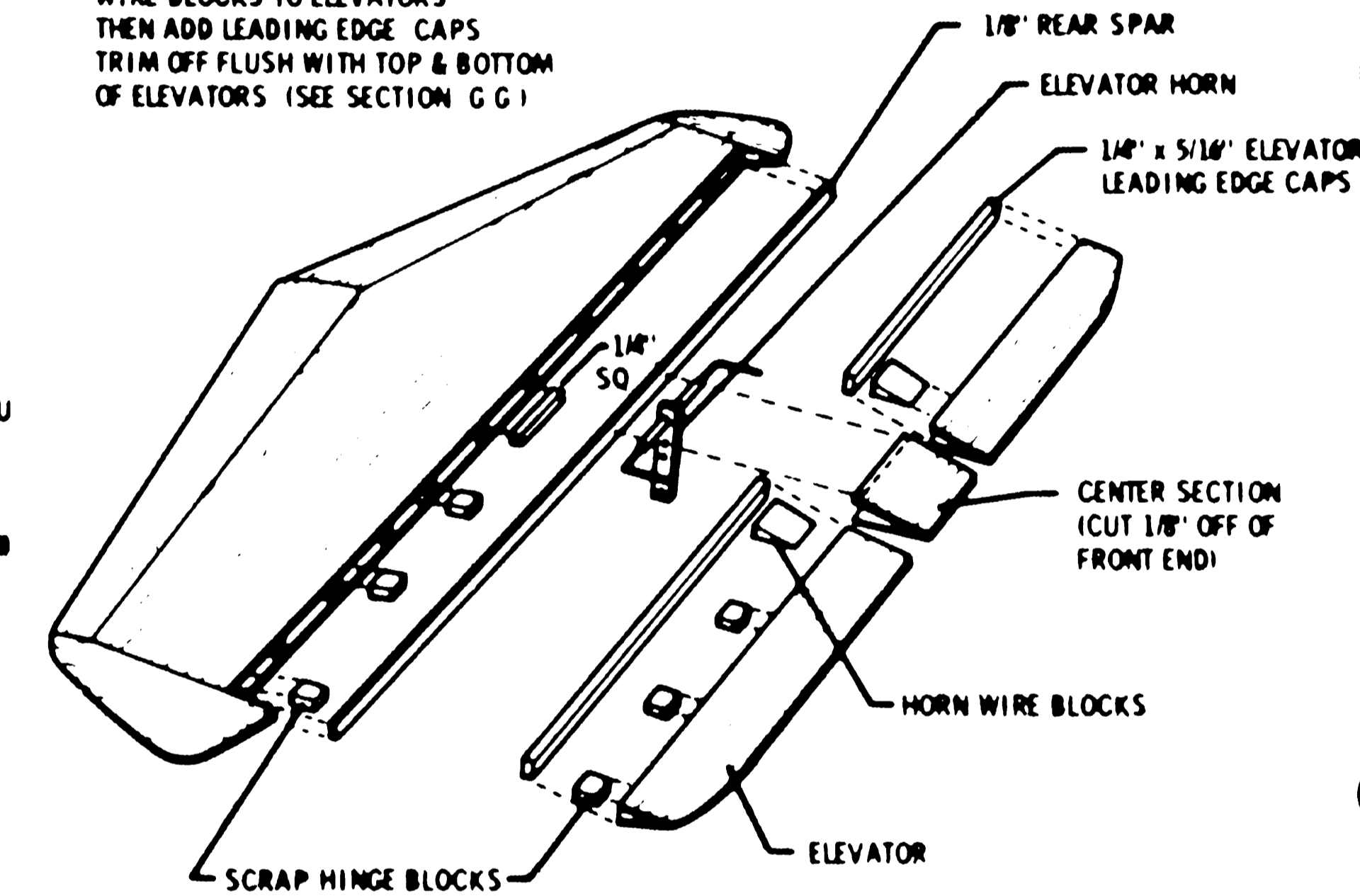

6 NOTCH REAR SPAR AS SHOWN IN MAIN LAYOUT. EPOXY ELEVATOR HORN IN PLACE - CEMENT CENTER SECTION BACK IN PLACE OVER HORN TAPER LEADING EDGES OF ELEVATOR. SILK ENTIRE STRUCTURE INCLUDING ELEVATORS. ADD HINGES AS DESIRED

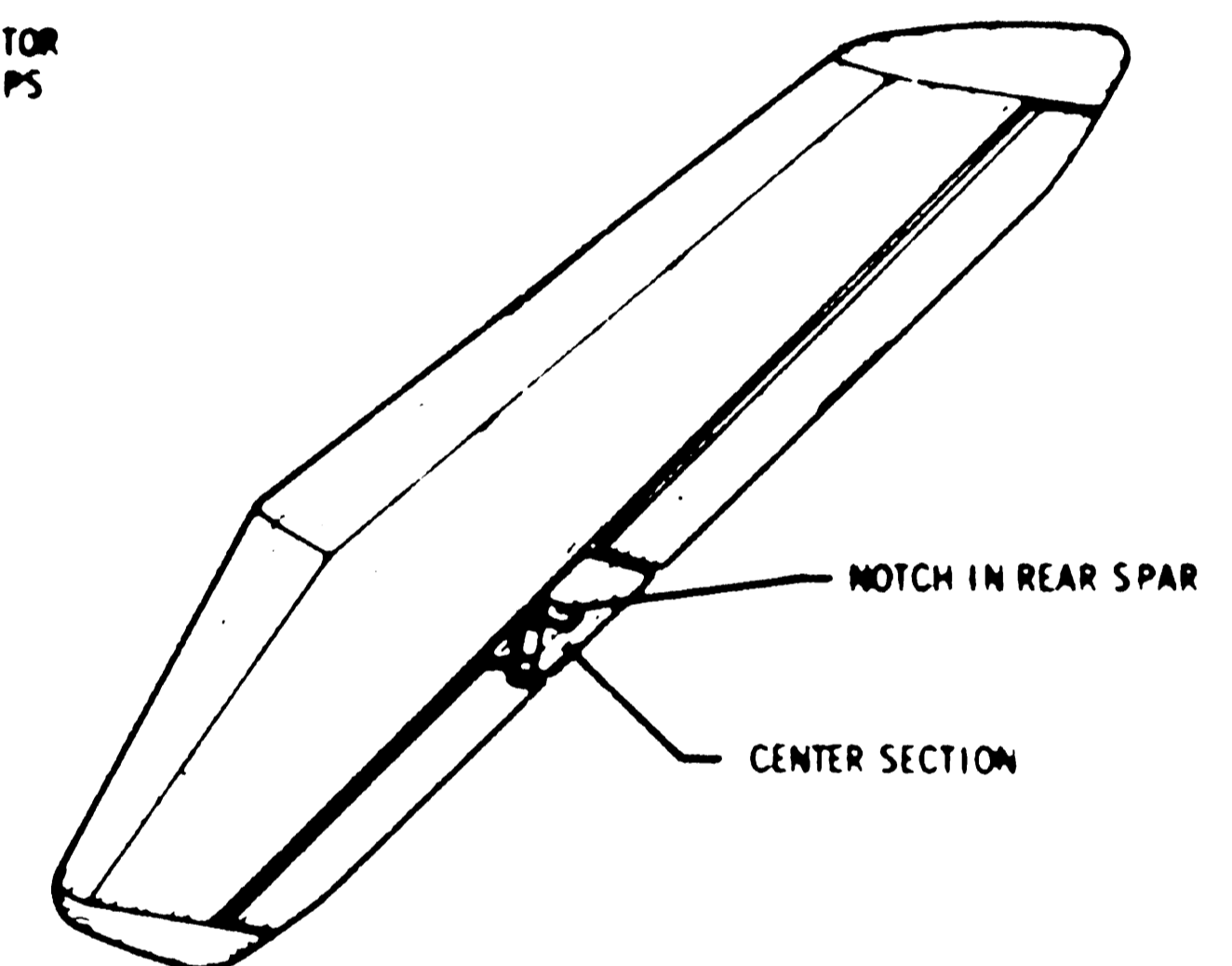

RUDDER DEFLECTION: AT LEAST 30° TO EACH SIDE FROM NEUTRAL
 ELEVATOR DEFLECTION: 40° UP FROM NEUTRAL AND 35° DOWN FROM NEUTRAL (PROPORTIONAL GEAR)
 AILERON DEFLECTION: 35° UP FROM NEUTRAL AND 25° DOWN FROM NEUTRAL

UNDER SIDE VIEW OF COMPLETED STAB AND ELEVATOR ASSEMBLY

BASIC STEPS IN CONSTRUCTION OF FUSELAGE

1 MAKE UP BASIC SIDES BY ASSEMBLING ITEMS AS SHOWN LEFT SIDE ASSEMBLY REVERSED

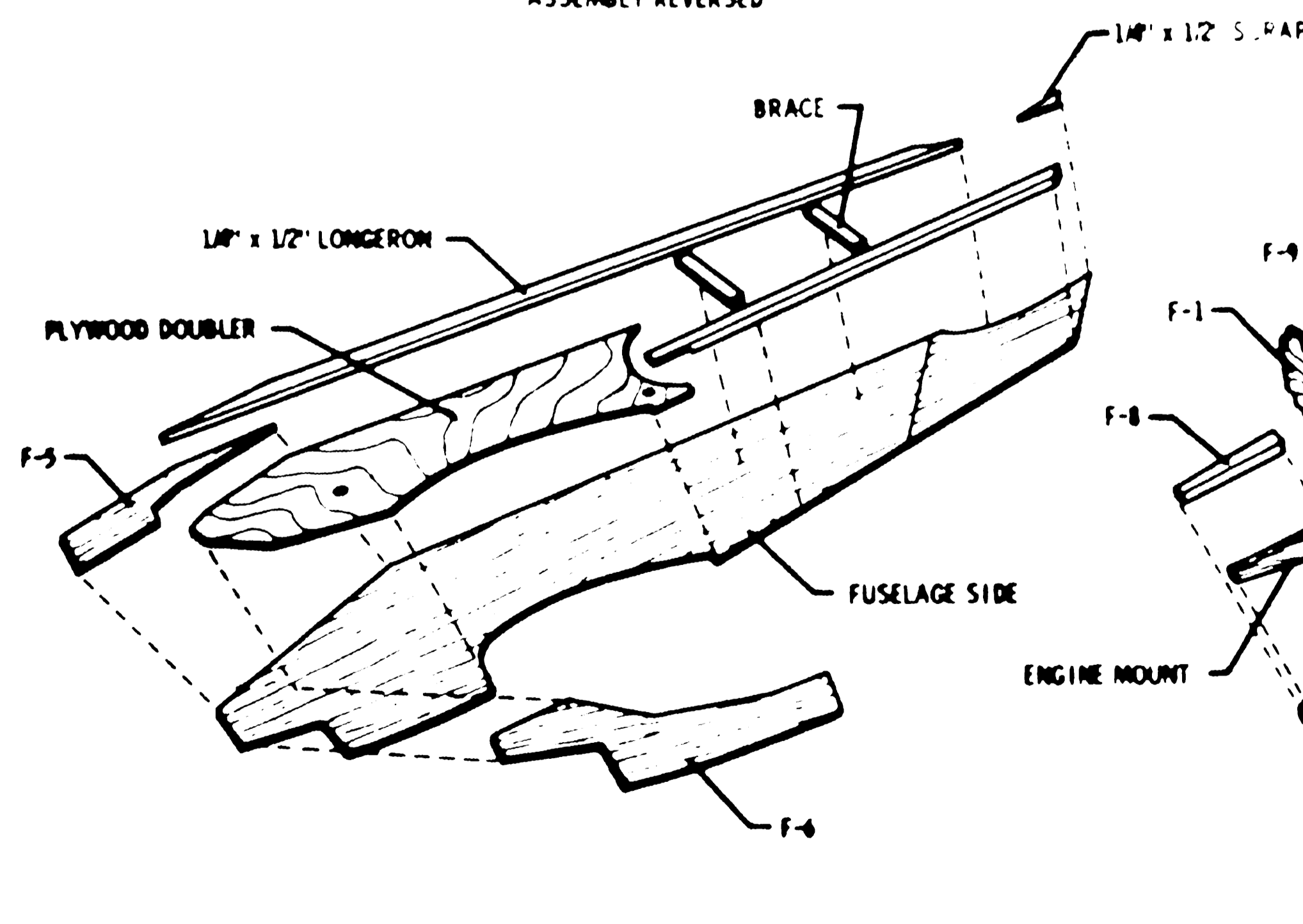

2 ADD ENGINE MOUNTS, FORMERS AND NOSE FILLER BLOCKS THEN ASSEMBLE BOTH SIDES TOGETHER

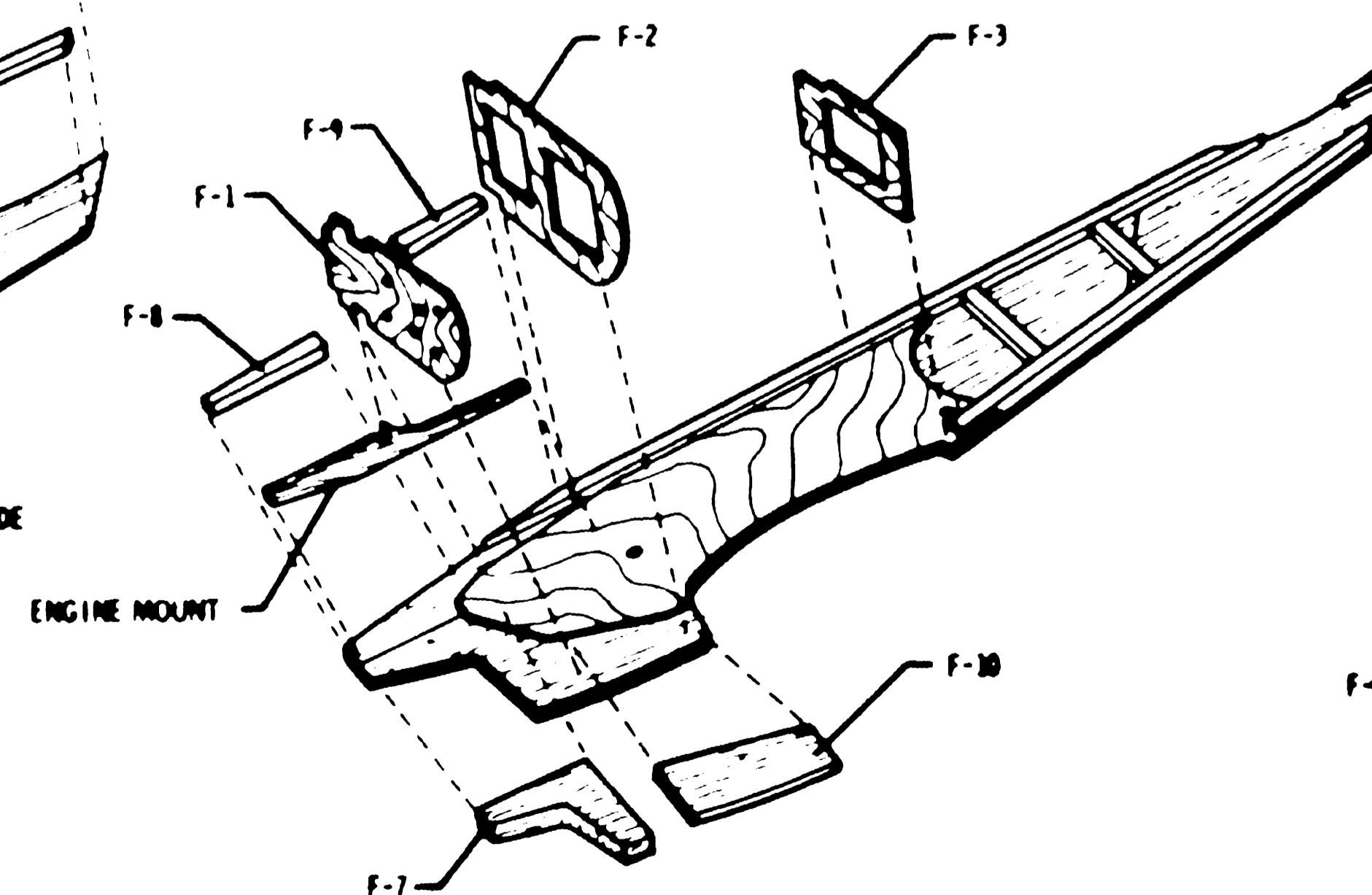

3 ADD F-14 AT REAR OF FUSELAGE, KEEP SIDES PROPERLY ALIGNED, TEMPORARILY FASTEN TOP & BOTTOM BLOCK, ADD F-4

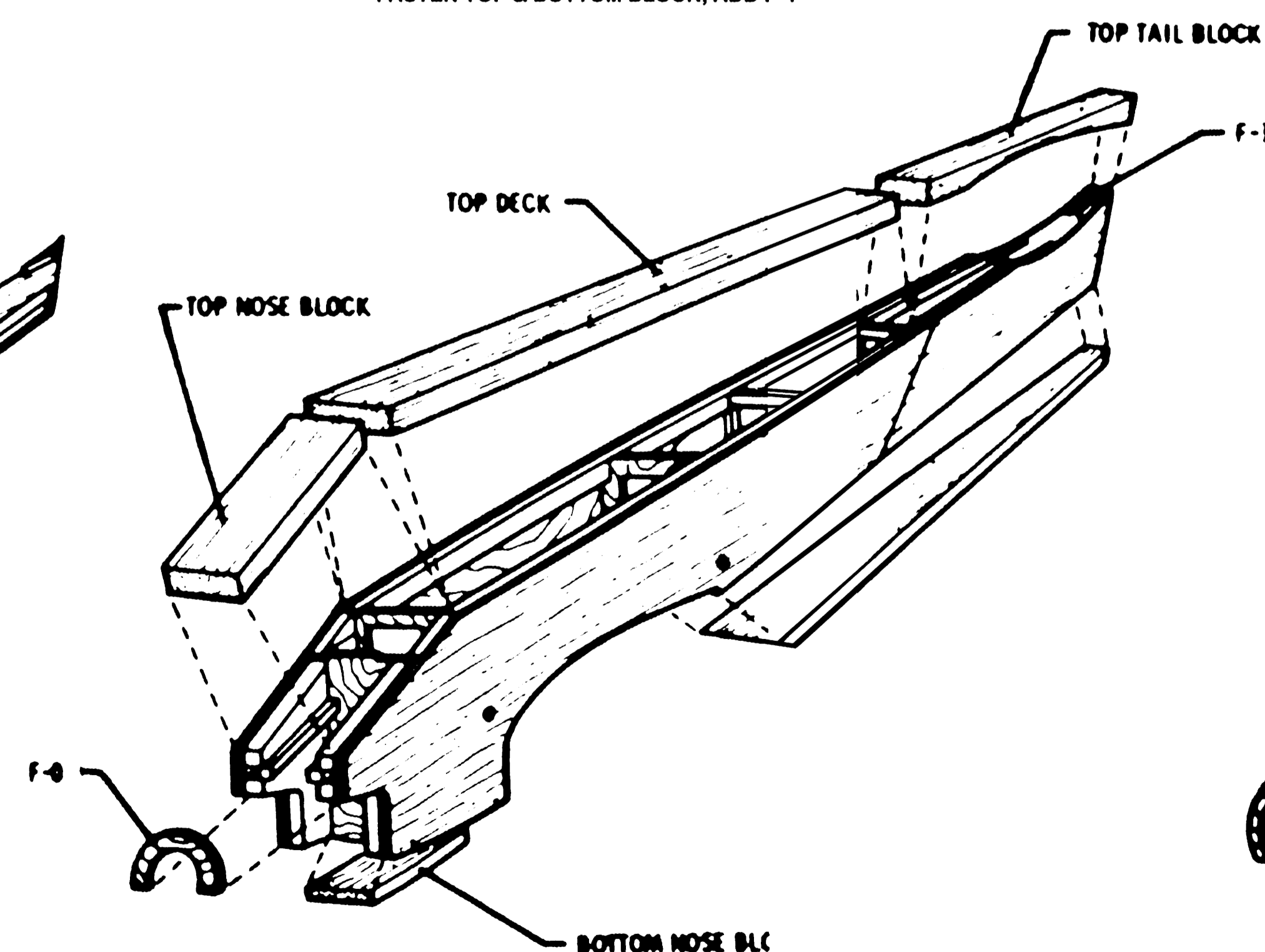

4 SHAPE OUTSIDE. REMOVE BLOCKS AND HOLLOW OUT IF DESIRED RECENT IN PLACE. ADD CANOPY BLOCK (REAR TOP BLOCK IS PERMANENTLY CEMENTED AFTER STAB IS IN PLACE)

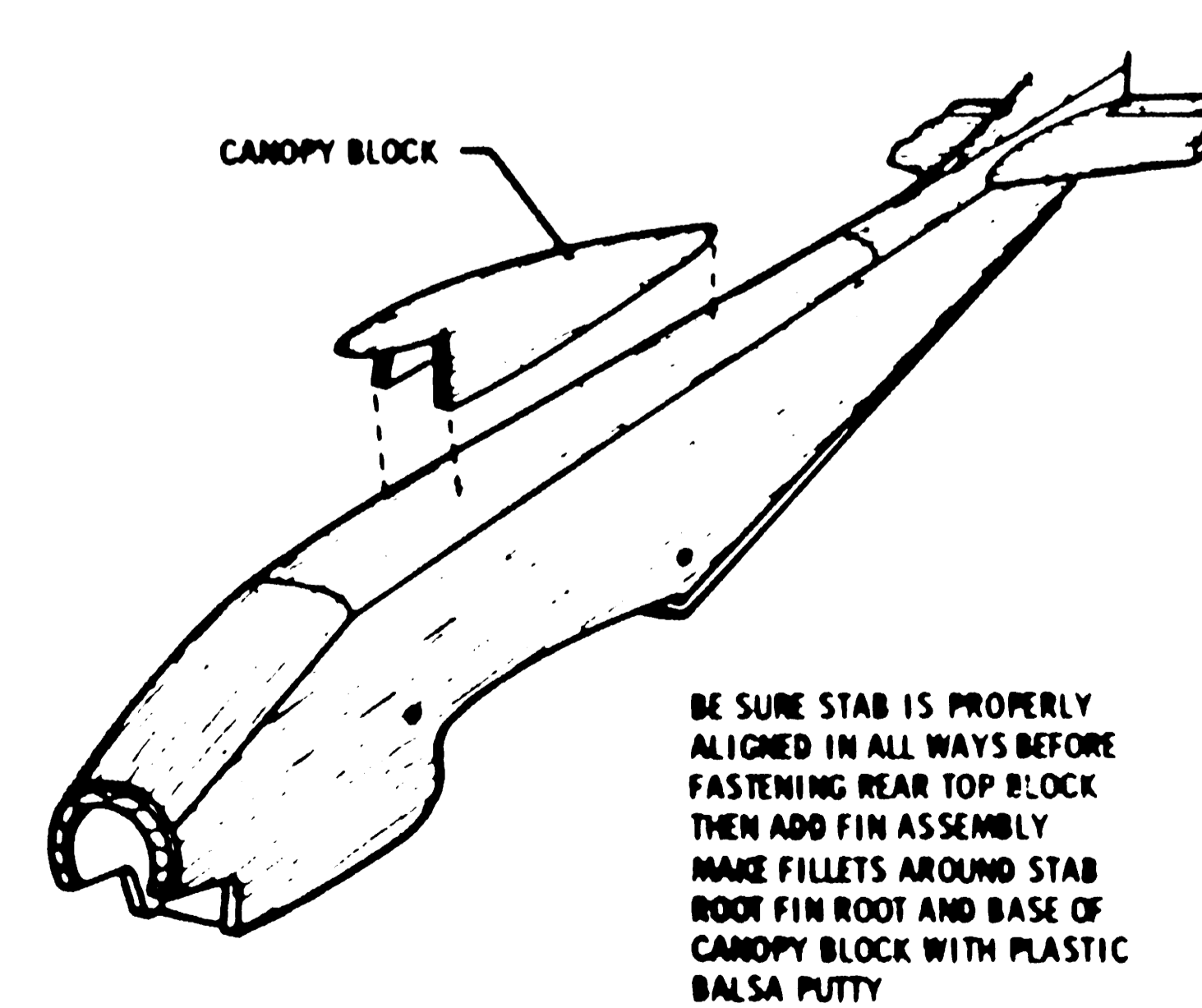

BE SURE STAB IS PROPERLY ALIGNED IN ALL WAYS BEFORE FASTENING REAR TOP BLOCK THEN ADD FIN ASSEMBLY MAKE FILLETS AROUND STAB ROOT FIN ROOT AND BASE OF CANOPY BLOCK WITH PLASTIC BALSA PUTTY

A AFTER WING IS COMPLETED AND SILKED, TURN FUSELAGE UPSIDE DOWN AND CAREFULLY FIT WING TO SADDLE IN FUSELAGE. CHECK CONSTANTLY TO MAINTAIN PROPER INCIDENCE. NOW CAREFULLY ALIGN WING ON SADDLE AND CARVE AND FIT FAIRING BLOCKS. CEMENT BLOCKS AND PLYWOOD PADS IN PLACE BEING VERY CAREFUL NOT TO DISLODGE WING FROM IT'S POSITION IN FUSELAGE SADDLE. WHEN DRY, FINISH SAND AND SILK FAIRING BLOCKS (SEE MAIN LAYOUT & SECTION D D)

