

ALL RIGHTS RESERVED. COMMERCIAL USE OF THIS PLAN IS STRICTLY INTERDITED.

**AVANTI**

DESIGNED & DRAWN BY DONALD A. GRASSI INKED BY DICK KIDD

www.rcmagazine.com

Sheet 1 of 2 Plan #558


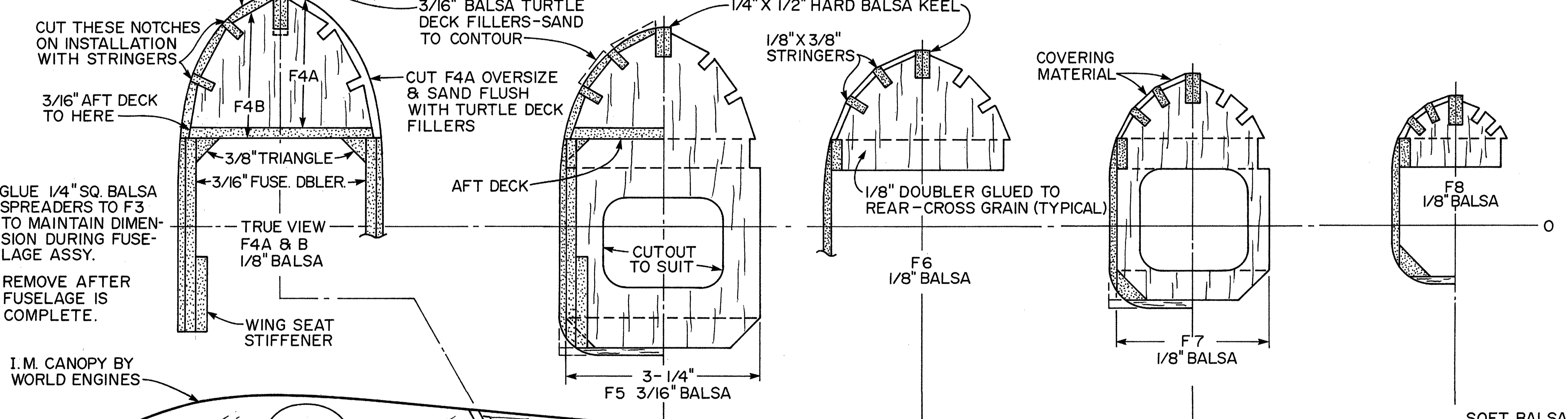
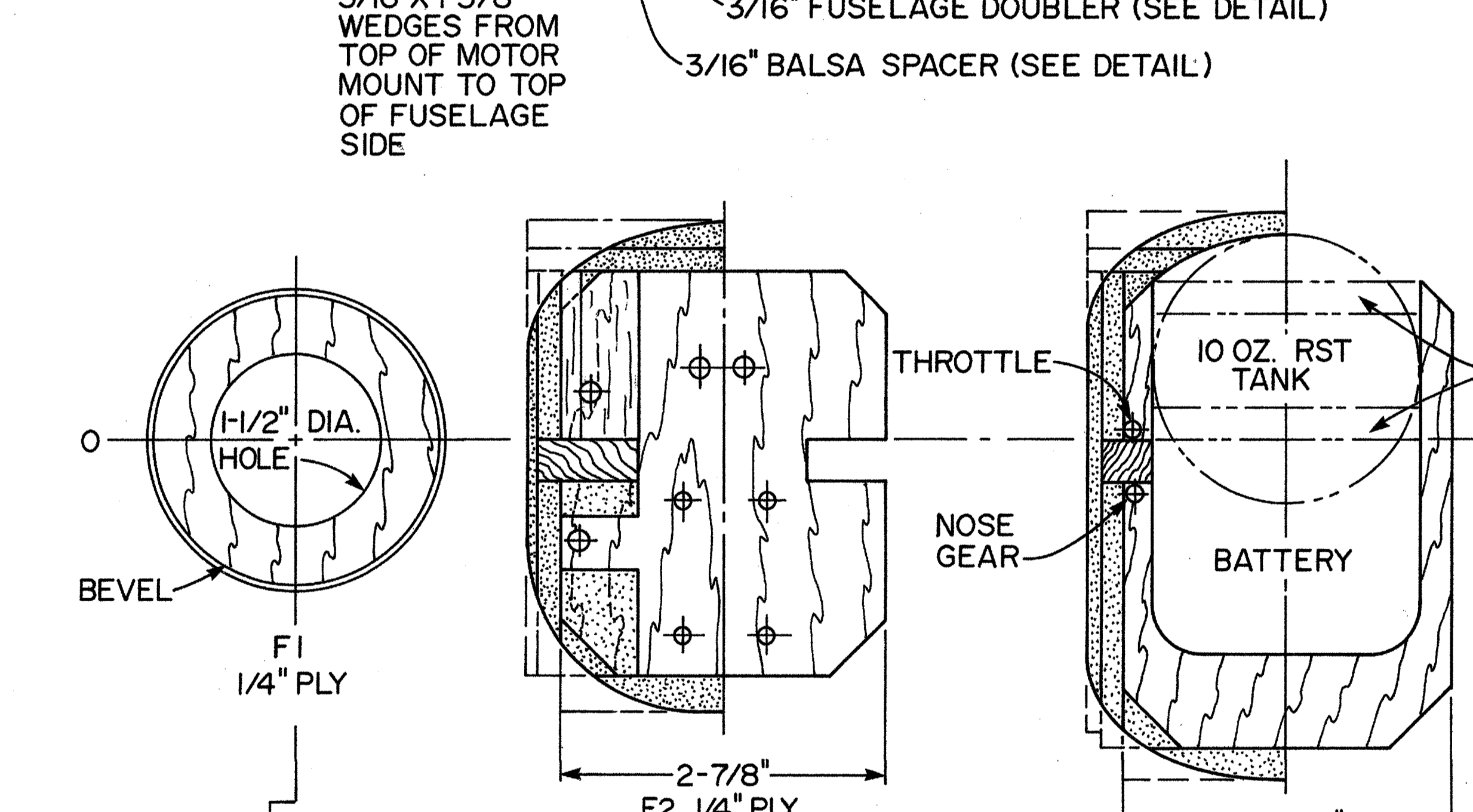

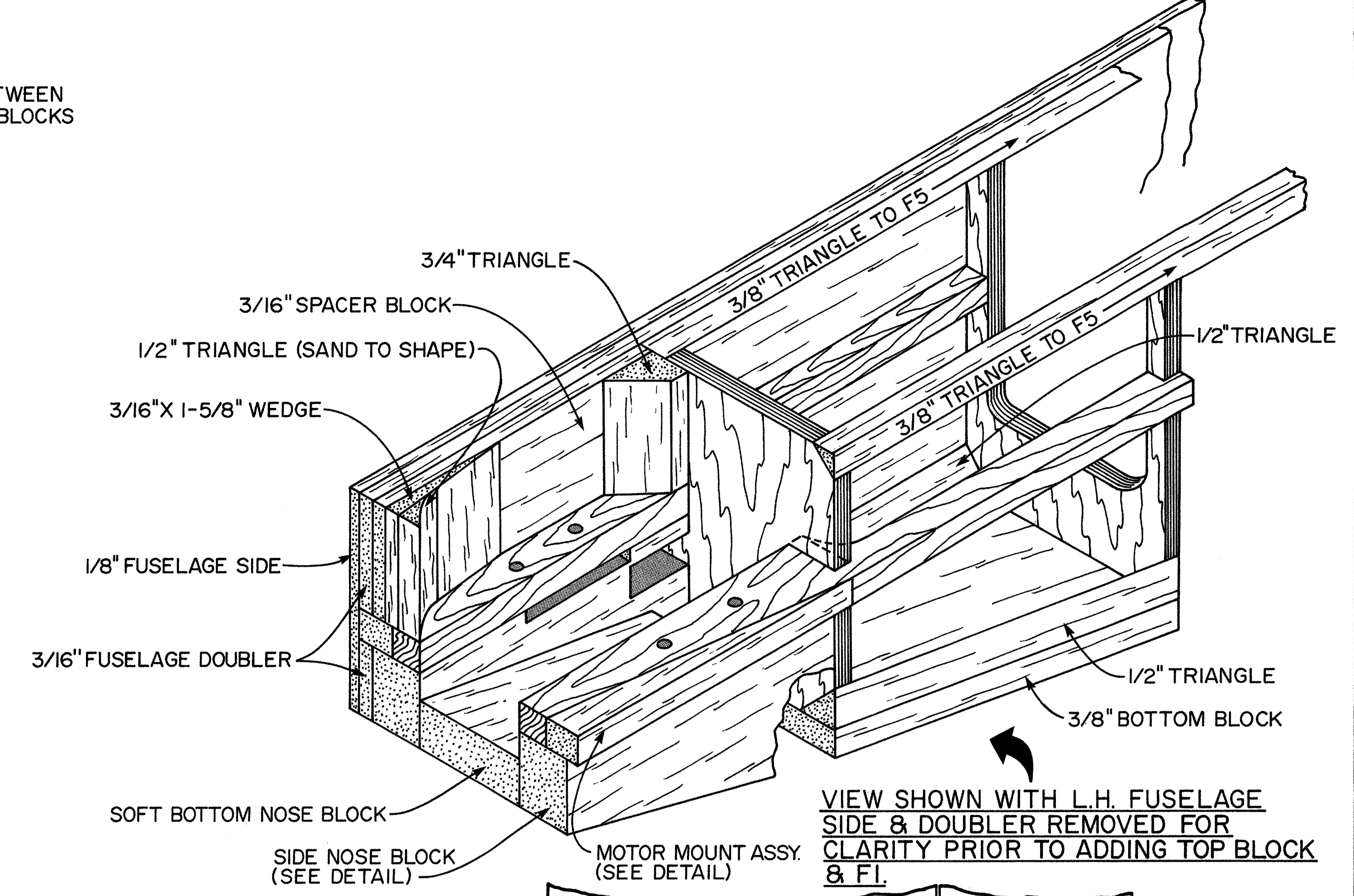
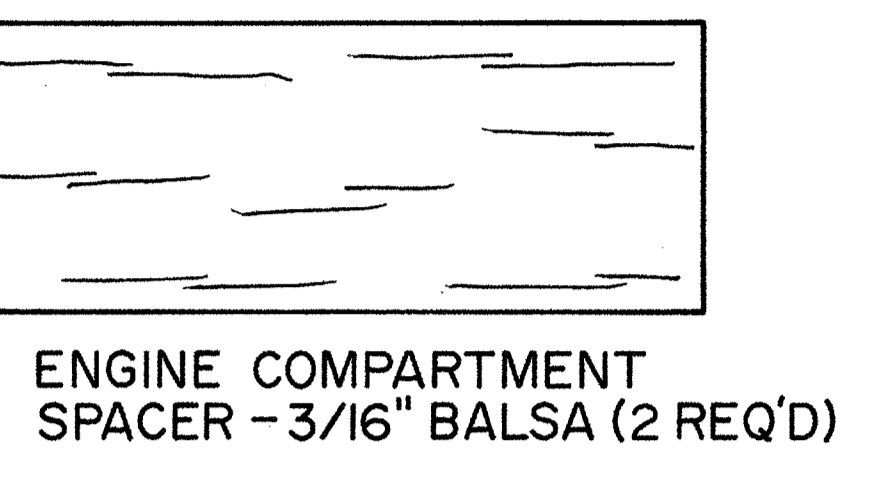
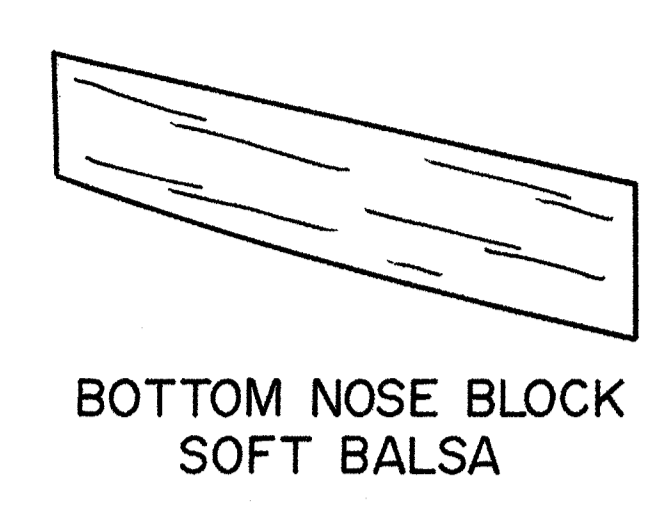
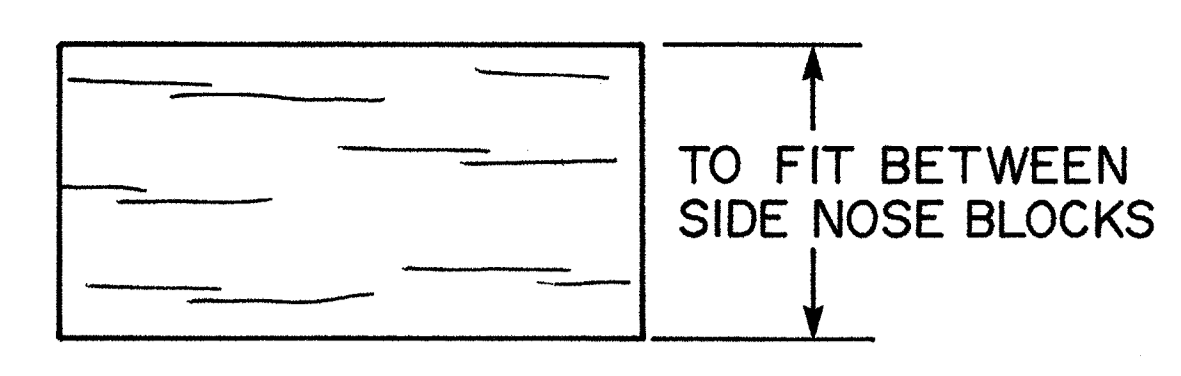
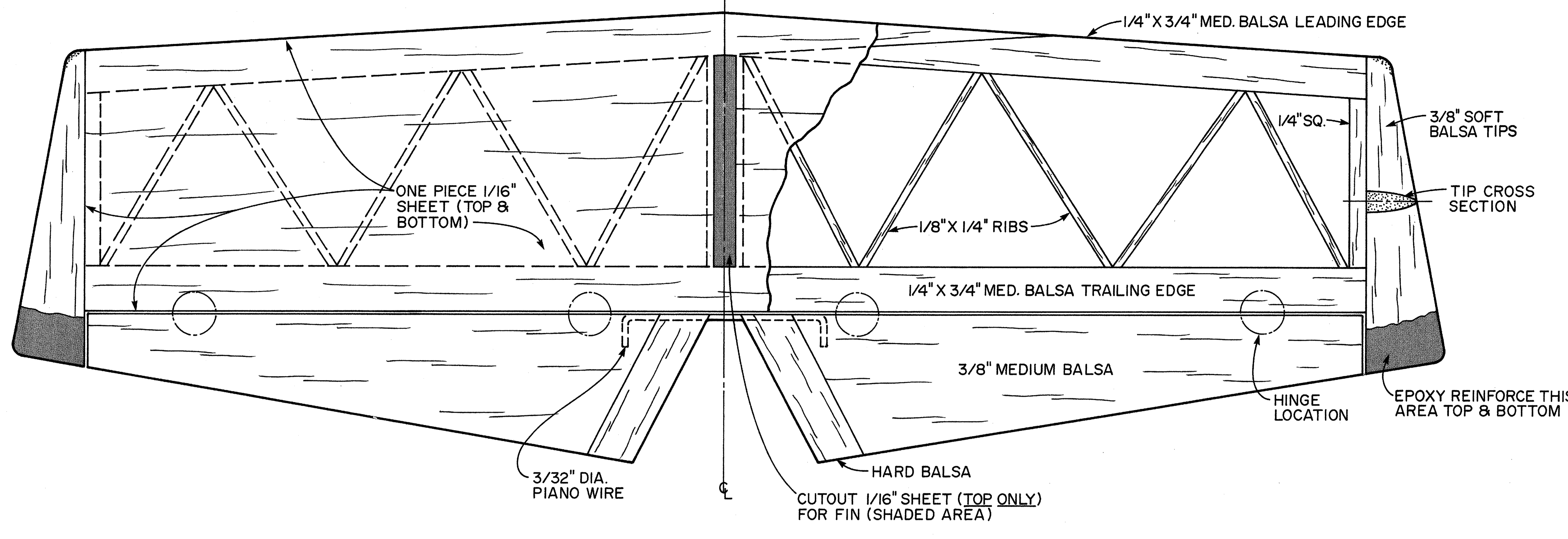

**SURFACE MOVEMENTS**  
 AILERONS - 5/16" UP 5/16" DOWN  
 ELEVATOR - 3/4" UP 3/4" DOWN  
 RUDDER - 1-1/4" LEFT 1-1/4" RIGHT

**SPECIFICATIONS**  
 WING SPAN - 60" WING AREA - 638 SQ. IN.  
 LENGTH - 52" WEIGHT - 100 OZ.  
 ENGINE DISP. - .60 CU. IN. PROP - 11-8  
 FOR EXPERIENCED FLYER

MAIN GEAR TEMPLATE  
 5/32" DIA. MUSIC WIRE  
 MAKE ONE AS SHOWN,  
 ONE OPPOSITE

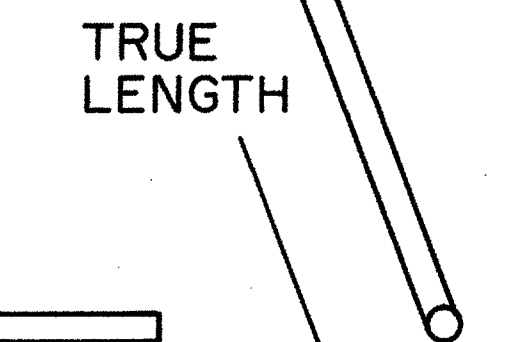

ALL RIGHTS RESERVED. COMMERCIAL USE OF THIS PLAN IS STRICTLY INTERDICTED.

**AVANTI**

DESIGNED & DRAWN BY DONALD A. GRASS | INKED BY DICK KIDD

www.rcmmagazine.com

Sheet 2 of 2 Plan #558