

NOTE: INSIGNIA RONDELS APPEAR ON TOP & BOTTOM OF BOTH WING PANELS.

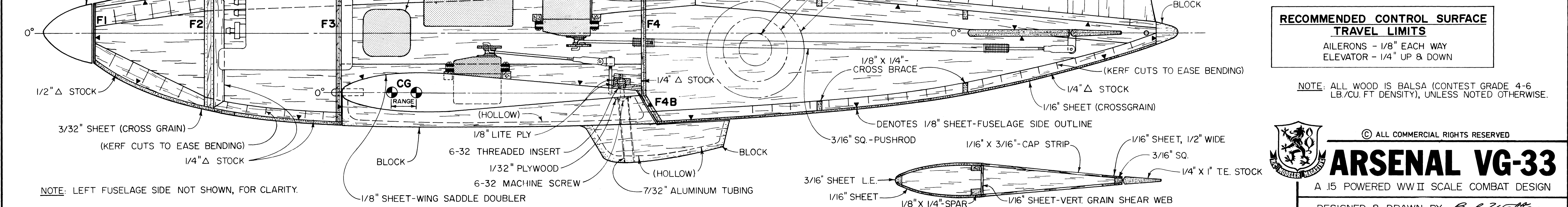
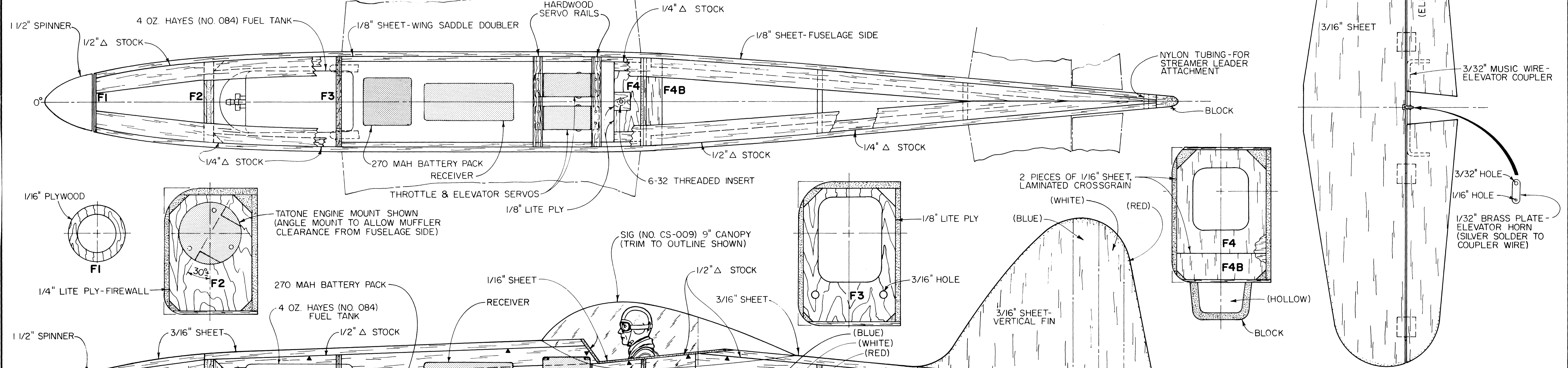
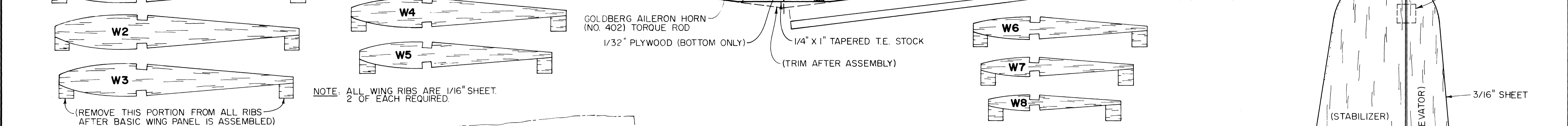
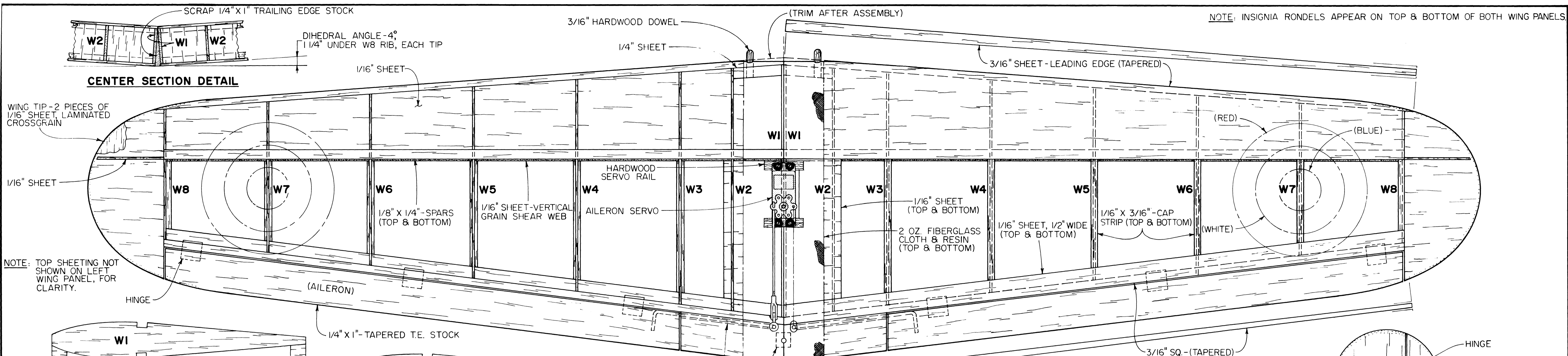

RECOMMENDED CONTROL SURFACE TRAVEL LIMITS

AILERONS - 1/8" EACH WAY

ELEVATOR - 1/4" UP & DOWN

NOTE: ALL WOOD IS BALSA (CONTEST GRADE 4-6 LB./CU. FT DENSITY), UNLESS NOTED OTHERWISE.

© ALL COMMERCIAL RIGHTS RESERVED

ARSENAL VG-33

A .15 POWERED WWII SCALE COMBAT DESIGN

DESIGNED & DRAWN BY *Bob Wallace*

TYPICAL WING SECTION